



# San Bernardino Valley Water Conservation District

Helping Nature Store Our Water

## **BOARD OF DIRECTORS MEETING AGENDA**

**Wednesday, April 13, 2022 – 1:30 p.m.**

Anyone wishing to listen to or participate in the meeting can join via Zoom:

**Call in (669) 900-6833, Meeting ID: 828 2351 1711**

To join the Zoom Meeting on <https://us02web.zoom.us/j/82823511711>

While the District makes every attempt to follow all guidance re COVID-19 safety protocols, the District cannot assure in-person attendees that they will not be exposed to COVID-19 or persons who have been so exposed, and attendees are advised to exercise caution in limiting their own incidences of exposure, particularly those who may be in groups at higher risk of infection, or serious symptoms of COVID-19 if infected.

Note: Copies of staff reports and other documents relating to the items on this agenda are on file at the District office and are available for public review during normal District business hours. New information relating to agenda topics listed, received, or generated by the District after the posting of this agenda, but before the meeting, will be made available upon request at the District office and in the Agenda Package on the District's website. It is the intention of the San Bernardino Valley Water Conservation District to comply with the Americans with Disabilities Act (ADA) in all respects. If you need special assistance with respect to the agenda or other written materials forwarded to the members of the Board for consideration at the public meeting, or if as a participant at this meeting you will need special assistance, the District will attempt to accommodate you in every reasonable manner. Please contact Athena Lokelani at (909) 793-2503 at least 48 hours prior to the meeting to inform her of your particular needs and to determine if accommodation is feasible. Please advise us at that time if you will need accommodations to attend or participate in meetings on a regular basis.

---

### **CALL TO ORDER PLEDGE OF ALLEGIANCE ROLL CALL**

---

#### **1. PUBLIC PARTICIPATION**

*Members of the public may address the Board of Directors on any item that is within the jurisdiction of the Board; however, no action may be taken on any item not appearing on the agenda unless the action is otherwise authorized by Subdivision (b) Section 54954.2 of the Government Code.*

#### **2. ADDITIONS/DELETIONS TO AGENDA**

*Section 54954.2 provides that a legislative body may take action on items of business not appearing on the posted agenda under the following conditions: (1) an emergency situation exists, as defined in Section 54956.5; (2) a need to take immediate action and the need for action came to the attention of the District subsequent to the agenda being posted; and (3) the item was posted for a prior meeting occurring not more than five calendar days prior to the date action is taken on the item, and at the prior meeting the item was continued to the meeting at which action is being taken.*

1630 W. Redlands Blvd, Suite A  
Redlands, CA 92373  
Phone: 909.793.2503  
Fax: 909.793.0188  
www.sbvwd.org Email: info@sbvwd.org

#### **BOARD OF DIRECTORS**

Division 1:  
Richard Corneille

Division 2:  
David E. Raley

Division 3:  
Robert Stewart

Division 4:  
John Longville

Division 5:  
Melody McDonald

#### **GENERAL MANAGER**

Daniel B. Cozad

- 3. **GUEST RECOGNITION/SELF INTRODUCTIONS**
- 4. **UPPER SANTA ANA RIVER HCP UPDATE, provided by Joanna Gibson of San Bernardino Valley Municipal Water District**
- 5. **PUBLIC MEETING RELATED TO ADOPTION OF GROUNDWATER CHARGE – 10 minutes**

*Article 1, Section 75560 of the California Water Code requires that a Water Conservation District that proposes to levy a groundwater charge "...shall annually cause to be made an engineering investigation and report upon groundwater conditions of the District." District staff will present the annual Bunker Hill Engineering Investigation Report and review the Groundwater Replenishment Program annual budget. District staff is recommending to the District's Board of Directors that an increase take place for fiscal year 2022-2023 in the amount of \$15.27 groundwater charge per acre-foot (af) for all groundwater production. As requested by the San Bernardino Basin Groundwater Council ("Council:), the District is also considering the addition of a Replenishment/Sustainability component to the groundwater charge, to be imposed on entities subject to the District's Groundwater Charge that are not members of the Council. The Council supports phasing in this charge over several years The proposed amount of such component is \$18.37 per acre foot but for the upcoming water year is proposed at the phase-in rate of seven dollars and thirty-five cents (\$7.35) per acre foot. District staff will present any written comments received and the board will hear oral comments.*

- *Open Public Meeting*
- [2022 Engineering Investigation Report Presentation \(if requested\)](#)
- *Staff Presentation on GW Sustainability/Replenishment Component and Groundwater Charge*
- *Groundwater Charge for FY 2022-2023 (M#1855) and Review Draft Resolution No. 599 for Groundwater Charge for 2022-2023.....6*
- *Receive Public Comments or Testimony*
- *Close Public Meeting*

- 6. **CONSENT CALENDAR**
  - A. Approval of Board Minutes, March 9, 2022 .....27
  - B. Approval of Expenditure Report, March 2022.....38
  - C. Absence Excusal for Board Member, March 9, 2022

7. **COMMITTEE REPORTS /ACTION ITEMS**

**Committee Reports**

A. **FINANCE & ADMINISTRATION VERBAL UPDATE**

**Presenter:** David E. Raley

**Recommendation:** The Chair of the Finance & Administration Committee will provide a verbal update of the meeting held on March 23.

B. **AD HOC AUDIT COMMITTEE VERBAL UPDATE**

**Presenter:** David E. Raley

**Recommendation:** The Chair of the Ad Hoc Audit Committee will provide a verbal update of the meeting held on March 30.

C. OPERATIONS COMMITTEE VERBAL UPDATE

**Presenter:** Richard Corneille

**Recommendation:** The Chair of the Operations Committee will provide a verbal update of the meeting held on April 4.

**Action Items**

D. 3<sup>RD</sup> QUARTER UNAUDITED FINANCIALS FOR 2021-2022 – 5 minutes (M#1856) .....49

**Presenter:** David E. Raley/Betsy Miller

**Recommendation:** The Finance & Administration Committee recommend the Board approve the 3<sup>rd</sup> Quarter 2021-2022 Financial reports as presented.

E. AGREEMENT AND ELECTION TO PREFUND EMPLOYER CONTRIBUTIONS TO A DEFINED BENEFIT PENSION PLAN WITH THE CALIFORNIA PUBLIC EMPLOYEES’ RETIREMENT SYSTEM INTERNAL REVENUE CODE SECTION 115 CALIFORNIA EMPLOYERS’ PENSION PREFUNDING TRUST – 5 Minutes (M#1857) .....54

**Presenter:** Betsy Miller

**Recommendation:** The Finance and Administration Committee recommend the Board: 1) Approve an Agreement and Election to Prefund Employer Contributions to a Defined Benefit Pension Plan; 2) Approve the Delegation of Authority to Request Disbursements to the General Manager; 3) Authorize the Board President to sign the Agreement and all associated documents; and 4) Approve as part of the annual budget an amount of up to two years annual CalPERS regular costs plus \$50,000 for future unfunded liabilities for deposit into the California Employers’ Pension Prefunding Trust from reserves.

F. UNAUDITED FINANCIAL REPORTS, March 2022 - 5 minutes (M#1858).....68

**Presenter:** Betsy Miller

**Recommendation:** Review and approve the unaudited financials for March 2022.

G. AUDITOR PROCUREMENT AND SELECTION FOR 2022 – 5 minutes (M#1859).....74

**Presenter:** Betsy Miller

**Recommendation:** The Ad Hoc Audit Selection Committee recommends the selection of Rogers, Anderson, Malody and Scott (RAMS) as the District’s Auditor for the 2022 audit and authorizes the General Manager to enter into an agreement for an amount not to exceed \$27,550 for the 2021-2022 audit. The agreement may be extended two additional years based on performance.

H. MENTONE SHOP IMPROVEMENTS CONSTRUCTION AWARD OF CONTRACT – 5 Minutes (M#1860) .....77

**Presenter:** Katelyn Scholte

**Recommendation:** 1. Accept the bid of CS-NK Construction Services in the amount of \$294,065 for design/build of the Mentone shop. 2. Accept the proposal for \$19,308.40 from CS-NK Construction Services to construct water and electrical service for the new shop. 3. Approve an agreement with CS-NK Construction Services in the amount of \$313,373.40 for design and construction services. 4. Approve a contingency fund, not included in the agreement, of \$7,000 for the design/build phase. 5. Approve a contingency fund, not included in the agreement, of \$29,406 for the construction phase for verified quantity overruns based on unit prices. 6. Authorize the General Manager to approve the expenditure of the contract and contingency funds, if needed, and order any necessary changes or additions in work performed under the contract with CS-NK Construction. 7. Authorize the General Manager to spend up to \$70,000 to obtain permits; install a septic system, additional property fencing, general cabinetry and shelving, fuel and



- E. April 27, 2022 Board of Directors Meeting/Groundwater Public Hearing, 1:30 p.m.
- F. April 27, 2022 Budget Workshop, 3:00 p.m. (*or immediately following Board meeting*) via Zoom/Teleconference
- G. May 3-May 6, 2022 ACWA Spring Conference, Sacramento  
***(Board Approval Required)***
- H. May 11, 2022 A Wellspring of Celebration Honoring 90 years of Preservation and Daniel Cozad, retiring General Manager 6:00 pm., Cuttle Weir
- I. June 6, 2022 Basin Technical Advisory Committee, 1:30 p.m. at Valley Municipal
- J. June 20, 2022 Association of San Bernardino County Special Districts Dinner hosted by the San Bernardino Valley Water Conservation District, 6:00 p.m. (location TBD)

11. **CLOSED SESSION**

1. The Board will meet in Closed Session under authority of Government Code §54956.9 (a), in order to discuss existing litigation, Endangered Habitats League et al. vs. U.S. Army Corps of Engineers, Central District Court Case no. Case No.: 2:16-cv-09178-MWF-E.
2. The Board will meet in Closed Session under authority of Government Code §54956.9 (a), in order to discuss existing litigation, San Bernardino Valley Water Conservation District v. Mark J. Bacher dba Red Dragonfly Spa, SBCSC Case No. LLTVA 2103055.
3. The Board may convene in Closed Session for Conference to discuss Real Property Negotiations pursuant to Government Code §54956.8; Owner: Southern California Edison East End Hydroelectric Generation Plant property located on various parcels and easements in Mil Creek and Santa Ana River Canyons, Negotiator: Daniel Cozad and David Cosgrove Owner: Southern California Edison Negotiators Allison, Bahen, Property Manager and Steven Powell, Vice President.

12. **ADJOURN MEETING.** The next regularly scheduled Board of Directors Meeting/Groundwater Public Hearing will be on April 27, 2022 at 1:30 p.m., at District Headquarters, 1630 W. Redlands Blvd., Redlands, CA and via Zoom/teleconference.



# San Bernardino Valley Water Conservation District

Helping Nature Store Our Water

Memorandum No. 1855

**To:** Board of Directors

**From:** Finance & Administration Committee  
Betsy Miller, Assistant General Manager

**Date:** April 13 and 27, 2022

**Subject:** Groundwater Charge for FY 2022-23

## **RECOMMENDATION**

Conduct a public meeting on April 13, 2022, regarding the proposed 2022-23 Groundwater Charge, and then continue the matter to April 27, 2022, for final action and adoption of a resolution approving an adjustment of the Groundwater Charge in the unitary amount of \$15.27 per acre-foot, for both agricultural and non-agricultural production. This change represents a five (5%) percent increase from the rates in effect for the prior year. In addition, approve a Sustainability Component of the Groundwater Charge in the amount of \$7.31, which represents the stepped increase in the phase-in period of such charge.

## **BACKGROUND**

The District reviewed and approved its annual Engineering Investigation for the 2022-23 water year (“EI”) on March 9, 2022. At the prior meeting on February 9, 2022, the District reviewed its Preliminary Groundwater Enterprise Budget for the upcoming year, and the Board gave staff direction on the advertised proposed Groundwater Charge rate to include in public notices. That advertised rate was \$15.27 per acre-foot, which represents a five (5%) percent increase from the rates in effect for the prior year, which is less than published cost of living increases year-to-year over the same period. The Board also gave direction on a step increase in the Sustainability Component of the Groundwater Charge, which is paid in order to “level the playing field” on costs of basin-benefitting water supply and recharge enhancement by the Groundwater Council, to \$7.35.

Today is the time set for a public meeting on the proposed adjustment to the District’s rate for the Groundwater Charge. A following public hearing will be held on April 27, 2022 at 1:30 pm, as per the District’s established custom, and consistent with applicable statutes governing Groundwater Charge processes. Notices of today’s public meeting and the April 27, 2022, public hearing were published on the District’s website, and in the San Bernardino County Sun and the Highland Community News on March 4<sup>th</sup>, 11<sup>th</sup>, and 18<sup>th</sup>. Mailed notice was also provided to all reporting groundwater producers on February 23, 2022. This provides more than the required forty-five (45) days between the date of that mailed notice and the proposed actual imposition of the Groundwater Charge on April 27, 2022, per California Constitution Article XIII D, Sec. 6(a)(2).

1630 W. Redlands Blvd, Suite A  
Redlands, CA 92373  
Phone: 909.793.2503  
Fax: 909.793.0188  
www.sbvwd.org Email: info@sbvwd.org

### **BOARD OF DIRECTORS**

Division 1:  
Richard Corneille

Division 2:  
David E. Raley

Division 3:  
Robert Stewart

Division 4:  
John Longville

Division 5:  
Melody McDonald

### **GENERAL MANAGER**

Daniel B. Cozad

As it has in the past, the decision to fix the Groundwater Charge rate comes with a series of findings regarding agricultural and non-agricultural groundwater production, annual and cumulative change in storage, and overall basin conditions. These findings are based upon the Engineering Investigation and required by statute. The findings, and the support for them, are set out in detail in the “Resolution Of The Board Of Directors Of The San Bernardino Valley Water Conservation District Establishing A Groundwater Charge On The Production Of Groundwater Within District Boundaries, And Making Certain Findings Relative Thereto” (“Resolution”), which is attached hereto, and submitted for the Board and public review. That Resolution also contains background and factual findings with respect to the Sustainability Component of the Groundwater Charge.

District staff has endeavored to comply with all procedural requirements applicable to the Groundwater Charge. For this reason, staff is recommending that the public meeting be opened today, and then continued until April 27, 2022, for a public hearing regarding final adoption of the Resolution.

### **DISCUSSION**

The recommendation from staff to adjust the Groundwater Charge rate is a function of the Groundwater Enterprise Budget, based on anticipated expenditures for the upcoming year. These topics were reviewed in detail by staff and the District Board on February 9, 2022. The staff report accompanying the February 9, 2022, review detailed budget revenue and expense projections, identified budget presumptions, and described the recent history of Groundwater Charge amounts and the initiation and implementation of the Sustainability Component. In the interest of avoiding repetition, that staff report is attached hereto, and its contents are incorporated herein by reference.

On balance, in considering the Budget, the Board directed that the “noticed” rate would be as set forth above, representing both the step increase in the five-year phase in of the Groundwater Charge Sustainability Component, which moves from \$4.41 to \$7.35 per acre foot, and a five (5%) increase in the Groundwater Charge rate, from \$14.41 to \$15.27 per acre foot. Those are the rates that have been proposed for consideration, and which are the subject of public review and comment both at the April 13, 2022, public meeting, and the April 27, 2022, public hearing. Obviously, the actual rate levied may vary, per Board direction and any public comments received.

### **POLICY CONSIDERATIONS**

Staff has previously provided a projection of groundwater production and revenue generated by the existing rate and the proposed expenditures for the Groundwater Enterprise Budget, to which proceeds from the proposed rates will be applied. The Finance and Administration Committee concurred in staff’s assessment that a five (5%) percent increase was warranted, both to address ongoing expenditures and capital project needs, and to stem the use of Rate Stabilization Funds.

### **FISCAL IMPACT**

The development and coordination of the Groundwater Charge is supported by the Groundwater Recharge Enterprise. The impact to reserves without an increase is approximately \$31,778.

**ATTACHMENTS OR MATERIALS**

Draft Groundwater Budget and staff report from February 9, 2022  
DRAFT Groundwater Charge Resolution No. 599

**APPROVALS**

Recommended by the Finance & Administration Committee  
Reviewed by District Counsel



# San Bernardino Valley Water Conservation District

Helping Nature Store Our Water

## ATTACHMENT

Memorandum No. 1839

**To:** Board of Directors

**From:** Daniel Cozad, General Manager

**Date:** February 9, 2022

**Subject:** Budget Planning for Groundwater Enterprise for 2022-2023, Proposed Groundwater Council Operations and Maintenance Fee and Advertised Groundwater Charge

## RECOMMENDATION

Review, discuss and approve issues for inclusion in the 2022-2023 Groundwater Enterprise Budget and provide direction to staff on Public Notice for the Groundwater Charge.

## BACKGROUND

Each year, San Bernardino Valley Water Conservation District (District) staff projects revenue and expense estimates for the Groundwater Enterprise, as underlying support for the Board to determine a proposed amount for the Groundwater Charge, for Public Notice purposes. The estimated amount included in the public notice does not set the charge, but does provide public notice of the potential proposed rate, for discussion purposes.

Following this analysis, the proposed Groundwater Charge rate is noticed in the newspaper and via mail to groundwater producers, and an opportunity is provided to the public to provide feedback at a Public Meeting and a Board Public Hearing to determine the annual groundwater charge. It is now time to consider that process again for the 2022-23 Groundwater Charge.

Groundwater Charge rates held steady (\$3.23 Agricultural/\$11.62 Non-Agricultural) from 2014 to 2016. In 2017, the rate was increased by 4%, with the previously-established Rate Stabilization Reserve fund used to moderate rate increases. In 2018, the Board approved an additional 4% increase in Non-Agricultural rates. That same year, in response to legal developments<sup>1</sup>, the Board determined that Agricultural rates should be incrementally raised over time, to match Non-Agricultural rates. The Board opted for a three-year phased approach to equalize Agricultural and Non-agricultural rates, relying again

<sup>1</sup> See, *City of San Buenaventura v. United Water Conservation District* (2017) 3 Cal. 5<sup>th</sup> 1191, which among other things, called into question the constitutionality of the rate differentials between the two types of rates, formerly required by Water Code section 75594. See discussion, *infra*.

1630 W. Redlands Blvd, Suite A  
 Redlands, CA 92373  
 Phone: 909.793.2503  
 Fax: 909.793.0188  
 www.sbvwd.org Email: info@sbvwd.org

### BOARD OF DIRECTORS

Division 1:  
Richard Corneille

Division 2:  
David E. Raley

Division 3:  
Robert Stewart

Division 4:  
John Longville

Division 5:  
Melody McDonald

### GENERAL MANAGER

Daniel B. Cozad

on the Rate Stabilization Reserve fund to bridge transitional shortfalls. In 2019 and 2020, the Board approved a 5% increase in Non-Agricultural rates, while Agricultural rates continued to be raised incrementally to match Non-Agricultural rates. There was no opposition to this change. For three years, the Rate Stabilization Reserve fund underwrote the shift from differential Agricultural and Non-Agricultural rates to a unitary rate, of \$13.85/AF

In 2021, the Board approved a change to rates increasing the unitary rate by 5% to \$14.54/AF and adding a replenishment sustainability component for SB County entities.

Over this same time period, Bunker Hill Groundwater Basin producers collaborated with the District to develop and approve a Groundwater Council (GC), formalized in 2018. The Groundwater Council offers a cooperative vehicle whereby members have created a method to equitably allocate basin recharge operations and maintenance costs, and to provide funding for basin replenishment with imported water, whenever feasible. Following two years of implementation, the GC payments and Groundwater Charge rates have proven effective to recover the majority of costs for the Groundwater Enterprise, as well as providing a cooperative regional funding source for taking advantage of variable imported water supplies, for local recharge.

### **DISCUSSION**

The Groundwater Enterprise fund revenue has met its expenditures for the past six years. Based on performance for the first half of the fiscal year, staff has projected a budget for Groundwater Enterprise operations and updated capital expenses. Staff has estimated a preliminary Groundwater Charge rate and initial GC revenue budget needed to offset these expenses. Staff has coordinated this cost with the GC, and GC members have supported the proposal.

The GC effectively serves as an alternative method for members to cover the District groundwater recharge operations costs, previously paid through the Groundwater Charge. The GC agreement was effective on February 27, 2018, and Fiscal Year 2018-2019 was the first budget year to utilize the GC funding mechanism. The City of Redlands joined the GC in 2021.

### **Budget Approach:**

The budget approach recommended by staff includes the following efforts and activities:

- Develop and review the draft budget with the GC and Groundwater Charge partners
- Utilize the Groundwater Enterprise Budget to develop the proposed Groundwater Charge
- Review the draft budget with the Finance & Administration Committee or in a Board Workshop before submitting it to the Board for approval
- Review other budgets with appropriate partners and stakeholders, as appropriate
- Utilize feedback from all of the above in the development of the final budget proposal

### **Assumptions**

The budget process is expected to use similar assumptions, based on the same factors, as the previous budgets. The budget also includes the following specific assumptions:

Revenue:

- Groundwater Charge revenue is based on actual charges paid in the prior year, with a review from the GC agencies
- GC revenue as calculated by the Equitable Allocation Model (“EAM”<sup>2</sup>) and paid by GC member agencies
- Producers who are not parties to the GC will continue to pay the Groundwater Charge
- Property tax will be estimated at the 2021 actual receipts
- Mining revenue will be estimated based on lease guaranteed annual minimum payments
- Interest revenue will be based on investment forecasts
- Consideration of the needs of the Active Recharge Transfer Project capital costs and limited interest income
- Revenue for Wash Plan Implementation from the Conservation Trust

Expenses:

- Expenses are estimated on a zero basis, or actual costs/estimates modified based on specific needs and actual 2020 costs.
- Board administrative costs and Staff COLA increases are based on Bureau of Labor Statistics CPI-U All West at 6.1% based on actual December 2021 rate of 7.1 but subtracting 1% raised in the last budget year [https://www.bls.gov/regions/west/news-release/consumerpriceindex\\_west.htm](https://www.bls.gov/regions/west/news-release/consumerpriceindex_west.htm)
- Utilities increase at approximately 5-7%, based on sector CPI or projected rate changes
- Salary forecast includes raise pool of up to 5% as a percentage of total salaries
- Miscellaneous expenses are generally increased at 5% where no other basis is available

During the 2016 budget process, the Board requested the full cost of capital improvements, repairs, and equipment in the budget. CEIP Costs are included at budget time as there are some operating revenue paid to capital projects and some capital funding of annual costs such as salaries and etc. CEIP costs in the current Groundwater Enterprise budget include the following:

- Mill Creek Diversion improvements, permitting, and construction
- Permitting for Mill Creek facilities
- Design and construction of the Mentone shop
- Replacement of heavy equipment
- On-going security repairs such as fencing, gates, boulders, and other barriers
- On-going land management such as removal of invasive, high-water-use species
- Design of the ARTP Projects

Based on the year-to-date budget information and the assumptions listed above, staff projects that a 5% increase in the Groundwater Charge is needed for 2022-2023.

---

<sup>2</sup> The EAM is the Groundwater Council’s method of assigning cost burdens to basin maintenance and operations, and to investments for purchase of imported water supplies, when available. It tries to balance historic water rights with later increases or decreases in production, to allocate burdens with an eye to respecting established rights, and current demand patterns of use. It therefore assigns costs based on equal weight to members’ (or their predecessors’) historical production (from 1959-1963), and more current production (from 2015-2019).

**Legal Changes and the Move to a Unitary Rate**

Throughout our history, the District has incorporated all requirements of the California Water Code (CWC), Prop 218, and Prop 26 into the rate setting process for the Groundwater Charge. We continue to carefully monitor legal cases related to the interpretation of voter initiatives, including Proposition (Prop) 13, Prop 218 and Prop 26, which seek to alter local governments' ability to raise taxes and fees without voter approval.

In *City of San Buenaventura v. United Water Conservation District, supra*, the California Supreme Court ruled that Groundwater Charges are not subject to Prop 218, but must meet the requirements of Prop 26. This requires that the charge or fee must 1) be no more than necessary to cover the costs of the activity; and 2) be allocated in a manner that bears a fair or reasonable relationship to the burdens or benefits from the activity. Further, the Court essentially invalidated CWC Section 75594, which required a 3-5:1 Non-Agricultural to Agricultural ratio for the charge. Before this decision, the District followed the requirements of CWC Section 75594, which resulted in a reduced Groundwater Charge for Agricultural production, which was also applied to parks, golf courses, schools, and cemeteries. This requirement that the Groundwater Charge be allocated in a manner related to the burden and benefit of the recharge replaced the statutorily-dictated cost ratio and, consistent with historical rate development, the District will continue to set the annual charge as necessary to recover the costs for the service provided (see attached Table on GW Charge History).

In setting the 2018 rates under these new legal parameters, the District did not believe there was sufficient factual record on variable costs between the Agricultural or Non-agricultural uses of groundwater production available to propose a defensible distinction of rate, based on relative burdens and benefits of the two categories of uses. No further information has become available since that time. Further, the District has not attempted to allocate its internal costs or field maintenance expenses based upon the distinction in use. Because Agricultural production is not limited to specific geographic areas within the District's boundaries, nor are District facilities designated solely, or even primarily, to Agricultural or Non-Agricultural use, the District Board approved a unitary rate for all production, regardless of type of use.

This change affected 30 producers producing approximately 10,815 acre feet from 52 wells. These producers paid groundwater charges of approximately \$35,879 in 2017. These users effectively received an increase in per acre foot rates of groundwater charges, due to the court-mandated discontinuance of the protected rate status for Agricultural use. Under a unitary rate in 2017, these 30 producers would have paid approximately \$131,300, with six users likely to be significantly affected due to the amount of recent production. These are primarily municipal users that now pay through the Groundwater Council.

To address these impacts to producers, the Board approved the utilization of the Groundwater Charge Stabilization Reserve over a three-year transition process, in which the Agricultural rate incrementally increased to a level of the Non-Agricultural rate. In 2018, staff undertook significant efforts to inform these producers of the change and provide multiple opportunities to participate in the process of setting the groundwater charge. Staff took the following actions at the Board's direction:

1. Produced and distributed information for all producers on the *Ventura v. UWCD* case and its implications
2. Held an informational workshop to explain the case, its effect on the Groundwater Charge and invited participants to attend the February 14 Board meeting to select the advertised rate
3. Mailed and advertised notices of Groundwater Charge change, including the potential phase-in period
4. Coordinated with Groundwater Council members
5. April 7<sup>th</sup> Public Meeting at Board meeting
6. April 21<sup>th</sup> Public Hearing to adopt rate at Board Meeting
7. Mailed an information sheet with the rate changes after adoption.

Throughout this time, including the informational workshop, Public Meeting, and Public Hearing, no Agricultural users indicated any opposition to the changes in rates. Certain Agricultural users who reached out for additional information noted their support for the Board's three-year transition process.

### **Groundwater Sustainability and Replenishment**

The Board, as part of last year's rate setting process approved a request from the GC to include a Replenishment/Sustainability component, as part of the Groundwater Charge. This component serves to make sure that those basin producers who are not GC members contribute proportionately to replenishment supplies, which GC members fund through their participation in the GC. This portion of the groundwater charge would be remitted after collection by the District to the GC, which would then use it to purchase imported water from San Bernardino Valley Municipal Water District, to replenish the basin.

On October 12, 2020, the GC approved a plan to achieve full financial participation from those remaining agencies that produce groundwater from the basin but have not yet become GC members. The replenishment component of the Groundwater Charge is in a proportionate amount so as to assure ratable contribution by such producers to basin wide replenishment efforts, and funding, now implemented by the GC and its members. This charge component is assessed as permitted under the District's organic act, and constitutional requirements, on San Bernardino County production within the District's jurisdictional boundaries, and in a manner whose results would mimic the allocations through the GC's EAM.

To explain, the idea would be to track the GC expenditures for imported recharge water over a defined time period (for this cycle, only two years of data would be available), come up with a normalized annual estimate (perhaps a rolling average of all years until five have passed, then a rolling five year average), as the benchmark of total water replenishment expenditures benefitting the basin. The total production ratio of the Other Producers during that same period, as compared to the GC members, would then be determined, to derive a "reasonable relationship" between the benefits achieved by Other Producers from GC recharge. The proportionate ratio of the total production from the Other Producers would then be applied to the normalized basin recharge expenditure figure, to determine the aggregate amount to be collected from the Other Producers, as part of the Groundwater Charge. That total monetary sum would then be allocated among the Other Producers pursuant to the EAM allocation. In this way, the total amount of groundwater charge raised by this Replenishment/Sustainability component paid by such Other Producers, in aggregate, would be no more than their proportionate benefit from basin recharge generally. The total cost would therefore not exceed the cost of the recharge activity basin wide, and the burden to

Other Producers would be based on their production as a group, allocated among them individually in the same manner as the GC does with its members. The goal would be to meet Proposition 26 requirements for total costs and reasonable benefit, while use of the EAM would “carry forward” for the Other Producers the GC’s balance between historical rights and present production, and place all basin producers, both GC members and Other Producers, on an even footing.

Staff used the same methodology to calculate a rate for non-GC member producers in the District boundary<sup>3</sup>. The replenishment/sustainability fee is estimated in Table 2, and would be up to \$20.00 per AF of production.

Staff reviewed these analyses with the GC and with the District’s Finance and Administration Committee. In recognition of concerns Staff proposed a phase-in period of five or more years to implement the fee, and reduce “rate shock.” The GC approved this phase-in period, and other elements implemented by the District Board. Last year staff conducted outreach to the producers affected by the proposed change to obtain feedback. No producers indicated resistance to the new component.

### **POLICY CONSIDERATIONS**

The Board provides direction to staff on the appropriate Groundwater Charge rate to advertise in the notices for the public meeting and hearing. Staff has reviewed the groundwater recharge operational costs to date for FY21-22 and Groundwater Recharge Enterprise revenue likely to be generated by the Groundwater Charge and the Groundwater Council. Staff believes that these data provide sufficient information to project the 2022-2023 Groundwater Recharge Enterprise needs. Following this analysis, staff recommends that the Board advertise a 5% increase in rates for the upcoming fiscal year. The recommendation is in keeping with prior Board direction to limit annual rate increases to 3-5% except in cases of significant policy or economic change. Because the Board acted proactively last year the 5% is still adequate for operations even though it is lower than overall inflation for the period.

### **ALTERNATIVES**

Potential Board actions include:

- Direct staff to advertise a 5% rate increase in notices and direct staff to advertise and continue phase in of the replenishment/sustainability component of ultimately up to \$20 per Acre Foot at full phase in in four more years.
- Provide staff direction to alter assumptions or other rate calculation methodology and the authority for selecting another advertised rate.

### **FISCAL IMPACT**

The annual development of the Groundwater Charge rate is supported by the Groundwater Recharge Enterprise. Without the proposed 5% rate increase in FY22, the impact to the Rate Stabilization Fund would be approximately \$31,778. The GC has recommended the proposed budget and will approve the budget in February or April. The replenishment/sustainability component is revenue neutral to the District as it would be segregated for exclusive use for transfer to the GC for purchased imported water.

---

<sup>3</sup> The City of Redlands is not included in the analysis, since it is expected to become a member of the Council.

**POTENTIAL MOTIONS**

1. Move to direct staff to advertise a 5% increase in the overall groundwater charge and continue the phase in of the Sustainability replenishment component.
2. Direct staff to advertise a 5% rate increase in notices year two of the replenishment/sustainability component ultimately up to \$20 per Acre Foot.
3. Move to direct staff to advertise another rate and approve the budget plan as shown herein.

**ATTACHMENTS OR MATERIALS**

- Draft Groundwater Enterprise Budget
- Groundwater Production and Charge Revenue Projection

GL ACCT: GL DESCRIPTION:		Approved 2021-2022 Budget	Projected Annual Costs (7/1/21- 6/30/22)	Draft 2022- 2023 Budget	GROUNDWATER RECHARGE ENTERPRISE		
<b>Draft 2022-2023 Budget</b>					2021 BUDGET:	% BUDGET	BASIS:
<b>INCOME:</b>							
4012	INTEREST INCOME-LAIF	4,000.00	2,000.00	3,234.28	0.00		
4013	INTEREST INCOME-CALTRUST	25,600.00	12,800.00	16,000.00	0.00	Groundwater Totals	
4015	INTEREST INCOME-UBS	27,860.00	13,930.00	13,986.00	0.00	\$ 1,497,192	
4016	INTEREST INCOME ARTP	216,000.00	108,000.00	216,000.00	0.00	0.00%	
4017	ARTP CAPITAL INCOME	615,000.00	307,500.00	615,000.00	0.00	0.00%	
4022	GROUNDWATER CHARGE	549,681.07	549,681.07	712,630.95	712,630.95	100.00% PER OFFSET	
4024	GROUNDWATER COUNCIL REVENUE	696,800.00	696,800.00	731,640.00	731,640.00	100.00% PROPOSED	
4025	GW SUSTAINABILITY/REPLENISHMENT	16,814.00	16,814.00	52,921.50	52,921.50	100.00%	
4031	PLANT SITE CEMEX	48,000.00	48,000.00	48,000.00	0.00		
4032	CEMEX - ROYALTY/LEASE	600,000.00	700,000.00	600,000.00	0.00		
4036	AGGREGATE MAINTENANCE	60,000.00	75,000.00	60,000.00	0.00		
4040	MISCELLANEOUS INCOME	10,000.00	10,000.00	10,000.00	0.00		
4043	PROJECT SALARY REIMBURSEMENT		20,000.00	20,000.00	0.00		
4050	PROPERTY TAX	130,817.65	130,817.65	137,358.53	0.00		
4055	SBVMWD LEASE AGREEMENT	421,846.12	431,810.98	449,083.42	246,995.88	55.00%	
4062	MENTONE PROPERTY INCOME	100.00	100.00	100.00	0.00		
4065	REDLANDS PLAZA	218,036.34	218,036.34	211,849.83	0.00		
4066	REDLANDS PLAZA CAM	44,906.35	44,906.35	45,707.27	0.00		
4080	EXCHANGE PLAN	30,000.00	0.00	0.00	0.00	100.00% HISTORIC	
4025	WASH PLAN REVENUE * from Reserves	220,000.00	914,569.26	220,000.00	0.00		
4086	PLUNGE CREEK IRWMP Grant	0.00	0.00	0.00	0.00		
4999	TRUST REIMBURSEMENT WASH PLAN	592,500.00	592,500.00	592,500.00	0.00		
<b>TOTAL INCOME:</b>		<b>4,527,961.52</b>	<b>4,893,265.65</b>	<b>4,756,011.78</b>	<b>1,744,188.33</b>		
<b>EXPENSES:</b>							
5080	LAFCO CONTRIBUTION/FEES	2,418.94	2,418.94	4,000.00	0.00		
5120	MISC. PROFESSIONAL SERVICES	300,000.00	300,000.00	300,000.00	75,000.00	25.00% Mill Creek Permitting init.	
5122	WASH PLAN PROFESSIONAL SERVICES	245,000.00	445,000.00	245,000.00	0.00		
5123	HABITAT MANAGEMENT-WP	346,250.00	346,250.00	346,250.00	0.00		
5124	PLUNGE CREEK PROFESSIONAL SERVICES	0.00	0.00	0.00	0.00		
5125	ENGINEERING SERVICES	30,000.00	30,000.00	30,000.00	30,000.00	100.00%	
5126	GW SUSTAINABILITY/REPLENISHMENT	16,814.00	16,814.00	16,814.00		100.00% Pass through of GC cost	
5127	PROJECT ACCOUNTING SERVICES						
5130	AERIAL PHOTO/SURVEYING/MARKET	2,200.00	2,200.00	2,200.00	0.00		
5133	Regional River HCP Contribution CIP #7	25,000.00	25,000.00	25,000.00	18,750.00	75.00%	
5155	WP TRAILS SERVICES	25,000.00	25,000.00	25,000.00	0.00		
5160	IT SUPPORT	8,500.00	8,500.00	8,500.00	3,825.00	45.00% Share by need	
5170	AUDIT	26,900.00	26,900.00	26,900.00	9,684.00	36.00% Share based on Revenue	
5175	LEGAL-WASH PLAN	5,000.00	13,387.50	5,000.00	0.00		
5180	LEGAL	25,000.00	25,000.00	25,000.00	3,750.00	15.00% GSC and COE Litigation	
<b>FIELD OPERATIONS:</b>							
5210	EQUIPMENT MAINTENANCE	7,200.00	7,200.00	7,200.00	7,200.00	100.00% based on average actual	
5215	PROPERTY MAINTENANCE	40,000.00	40,000.00	40,000.00	32,000.00	80.00% Basin Maintenance Moved	
5223	TEMP FIELD LABOR	10,000.00	10,000.00	10,000.00	10,000.00	100.00% Invasive and canal cleaning	
5225	FIELD CLEAN UP-DUMPING/VECTOR	60,000.00	60,000.00	60,000.00	36,000.00	60.00%	
5050	BASIN CLEANING FORMERLY 7050 CAPITA	50,000.00	50,000.00	50,000.00	50,000.00	100.00%	

GL ACCT:                      GL DESCRIPTION:		Approved 2021-2022 Budget	Projected Annual Costs (7/1/21- 6/30/22)	Draft 2022- 2023 Budget	GROUNDWATER RECHARGE ENTERPRISE		
<b>Draft 2022-2023 Budget</b>					2021 BUDGET:	% BUDGET	BASIS:
<b>VEHICLE OPERATIONS:</b>							
5310	VEHICLE MAINTENANCE	8,000.00	8,000.00	8,000.00	8,000.00	100.00%	reduced from 2013-14 base
5320	FUEL	15,125.00	15,125.00	16,637.50	16,637.50	100.00%	EST. LOWER FUEL COST
<b>UTILITIES:</b>							
5410	ALARM SERVICE	1,545.00	1,545.00	1,800.00	900.00	50.00%	FACILITIES SHARE
5420	ELECTRICITY	7,563.42	9,454.28	11,438.00	2,287.60	20.00%	FACILITIES SHARE
5430	MOBILE PHONES	5,370.30	5,370.30	5,850.00	4,387.50	75.00%	FACILITIES SHARE
5440	TELEPHONE	6,000.00	6,000.00	6,000.00	1,800.00	30.00%	FACILITIES SHARE
5450	NATURAL GAS	1,155.00	1,155.00	1,000.00	400.00	40.00%	FACILITIES SHARE
5460	WATER / TRASH / SEWER	3,609.90	3,609.90	3,790.40	1,516.16	40.00%	FACILITIES SHARE
5470	INTERNET SERVICES	2,750.00	2,750.00	2,750.00	825.00	30.00%	FACILITIES SHARE
<b>GENERAL ADMINISTRATION:</b>							
6001	GENERAL ADMIN-OTHER	4,500.00	4,500.00	4,500.00	2,250.00	50.00%	ESTIMATE BY USE
6002	WEBSITE ADMINISTRATION	6,000.00	6,000.00	6,000.00	0.00		
6003	PROPERTY TAX	0.00	0.00	0.00	0.00		
6004	MEETING EXPENSES	2,060.00	2,060.00	2,060.00	0.00		
6006	PERMITS	45,000.00	170,098.33	45,000.00	33,750.00	75.00%	Fish and Wildlife
6007	INTER DISTRICT COSTS	10,000.00	10,000.00	10,000.00	5,000.00	50.00%	
6009	LICENSES	1,712.06	1,712.06	1,709.00	1,367.20	80.00%	
6010	SURETY BOND	1,900.00	1,900.00	1,900.00	0.00		
6012	OFFICE MAINTENANCE	2,550.80	2,550.80	5,101.60	0.00		
6013	OFFICE LEASE PAYMENT	50,000.00	50,000.00	50,000.00	10,000.00	20.00%	Share by allocation
6015	MENTONE HOUSE MAINTENANCE	3,500.00	3,500.00	3,500.00	0.00		
6016	REDLANDS PLAZA MAINTENANCE	35,000.00	35,000.00	35,000.00	0.00		
6026	REDLANDS PLAZA CAM EXPENSES	32,936.31	32,936.31	33,595.04	0.00		
6018	JANITORIAL SERVICES	10,400.00	10,400.00	10,200.00	0.00		
6019	JANITORIAL SUPPLIES	515.00	515.00	375.00	150.00	40.00%	FACILITIES SHARE
6020	VACANCY MARKETING-REDLANDS PLAZA	5,000.00	5,000.00	5,000.00	0.00		
6027	COMPUTER SOFTWARE	2,000.00	2,000.00	2,000.00	100.00	5.00%	FACILITIES SHARE
6030	OFFICE SUPPLIES	3,500.00	5,500.00	5,500.00	275.00	5.00%	FACILITIES SHARE
6033	OFFICE EQUIPMENT RENTAL	9,500.00	9,500.00	9,500.00	475.00	5.00%	FACILITIES SHARE
6036	PRINTING	2,000.00	2,500.00	2,200.00	880.00	40.00%	GW Charge
6039	POSTAGE AND OVERNIGHT DELIVERY	1,200.00	1,200.00	1,200.00	300.00	25.00%	GW Charge
6042	PAYROLL PROCESSING FEES	2,859.13	2,859.13	3,002.09	0.00		
6045	BANK INVESTMENT SERVICE CHARGES	1,000.00	1,000.00	750.00	0.00		
6051	UNIFORMS	3,025.00	3,025.00	3,025.00	2,117.50	70.00%	Field Uniforms
6060	OUTREACH	60,000.00	60,000.00	60,000.00	12,000.00	20.00%	share by mission
6087	EDUCATIONAL REIMBURSEMENT	5,000.00	5,000.00	5,000.00	0.00		
6090	SUBSCRIPTIONS/PUBLICATIONS	1,355.20	1,800.00	2,150.00	0.00		
6091	PUBLIC NOTICES	3,200.00	3,200.00	3,200.00	2,560.00	80.00%	% OF 2010
6093	MEMBERSHIPS	25,289.23	25,289.23	24,276.15	0.00		
<b>BENEFITS:</b>							
6110	VISION INSURANCE	2,881.79	2,881.79	3,169.97	1,740.31	45%	Based on percent of hours
6120	WORKER'S COMP INSURANCE	16,564.84	16,564.84	17,925.35	9,841.02	45%	Based on percent of hours
6130	DENTAL INSURANCE	10,548.37	10,548.37	11,227.52	6,163.91	45%	Based on percent of hours
6150	MEDICAL INSURANCE	239,303.51	239,303.51	251,727.10	138,198.18	45%	Based on percent of hours
6150.01	MEDICAL EMPLOYEE CONTRIBUTION	-31,135.79	-31,135.79	-28,211.94	-12,695.37	45%	
6160	PAYROLL TAXES - EMPLOYER	102,949.70	102,949.70	101,231.56	55,576.13	45%	Based on percent of hours

GL ACCT:                      GL DESCRIPTION:		Approved 2021-2022 Budget	Projected Annual Costs (7/1/21- 6/30/22)	Draft 2022- 2023 Budget	GROUNDWATER RECHARGE ENTERPRISE		
<b>Draft 2022-2023 Budget</b>					2021 BUDGET:	% BUDGET	BASIS:
6170	PERS RETIREMENT	296,477.60	296,477.60	245,457.40	134,756.11	45%	Based on percent of hours
6170.01	PERS EMPLOYEE CONTRIBUTION	-45,326.73	-45,326.73	-53,466.60	-24,059.97	45%	
<b>SALARIES:</b>							
6210	OVERTIME				0.00		763,181.04
6230	REGULAR SALARIES	1,422,210.29	1,422,210.29	1,404,966.92			
Sub	Field Staff Part Time				0.00	50.00%	Salary+overhead 22% % time
Sub	Field Supervisor	90,898.08	90,898.08	93,682.06	114,292.11	100.00%	Salary+overhead 22% time
Sub	Field Operations Spec I	55,582.80	55,582.80	60,086.21	73,305.17	100.00%	Salary+overhead 22% time
Sub	Field Operations Spec I	45,339.84	45,339.84	48,995.11	53,796.63	90.00%	Salary+overhead 22% time
Sub	Lands Resources Mgr.	214,503.33	214,503.33	195,565.00	95,435.72	40.00%	Salary+overhead 22% time
Sub	Admin Services Spec.	87,709.44	87,709.44	90,393.80	44,112.18	40.00%	Salary+overhead 22% time
Sub	Admin Analyst	88,932.48	88,932.48	91,651.73	33,544.53	30.00%	Salary+overhead 22% time
Sub	Senior Engineer (Part-time)	169,827.84	169,827.84	94,900.00	23,155.60	20.00%	Salary+overhead 22% time
Sub	District Engineer	78,689.52	78,689.52	88,252.51	53,834.03	50.00%	Salary+overhead 22% time
Sub	Assistant Engineer			77,392.00	47,209.12	50.00%	Salary+overhead 22% time
Sub	Legal Counsel	250,000.00	250,000.00	265,253.40	97,082.74	30.00%	Salary+overhead 22% time
Sub	GIS Intern/contract	15,695.62	15,695.62	16,531.68	20,168.65	100.00%	Salary+overhead 22% time
Sub	General Manager	296,783.34	296,783.34	250,000.00	91,500.00	30.00%	Salary+overhead 22% time
Sub	Doc Imaging Intern	12,840.00	12,840.00	15,731.76	7,677.10	40.00%	Salary+overhead 22% time
sub	Engineering Intern	15,408.00	15,408.00	16,531.68	8,067.46	40.00%	Salary+overhead 22% time
<b>INSURANCE:</b>							
6310	PROPERTY / AUTO INSURANCE	4,420.13	4,828.74	5,070.18	3,802.63	75.00%	Approximate from Insurer
6320	GENERAL LIABILITY INSURANCE	33,651.74	35,708.99	36,423.17	27,317.38	75.00%	Approximate from Insurer
<b>DIRECTOR'S EXPENSES:</b>							
6401	DIRECTOR'S FEES	87,901.20	87,901.20	90,632.40	0.00		
6410	MILEAGE	4,000.00	4,000.00	4,000.00	0.00		
6415	AIR FARE	2,500.00	2,500.00	3,000.00	0.00		
6420	OTHER TRAVEL	500.00	500.00	500.00	0.00		
6425	MEALS	3,500.00	3,500.00	3,500.00	0.00		
6430	LODGING	4,000.00	4,000.00	4,000.00	0.00		
6435	CONF/SEMINAR REGISTRATIONS	5,000.00	5,000.00	5,000.00	0.00		
6440	ELECTION FEES/REDISTRICTING	25,000.00	25,000.00	0.00	0.00		
<b>ADMINISTRATIVE/STAFF EXPENSES:</b>							
6510	MILEAGE	2,500.00	2,500.00	2,500.00	625.00	25.00%	Allocation basis 2011
6515	AIR FARE	4,500.00	4,500.00	4,500.00	450.00	10.00%	Allocation basis 2011
6520	OTHER TRAVEL	1,500.00	1,500.00	1,500.00	375.00	25.00%	Allocation basis 2011
6525	MEALS	2,035.00	3,500.00	2,177.45	762.11	35.00%	Allocation basis 2011
6530	LODGING	3,750.00	3,750.00	3,825.00	1,338.75	35.00%	Allocation basis 2011
6535	CONF/SEMINAR REGISTRATIONS	4,000.00	4,000.00	4,000.00	1,400.00	35.00%	
6600	REPLENISHMENT WATER PURCHASE GC	16,814.00	16,814.00	52,921.50	52,921.50	100.00%	
9999	Contribution toward Capital Maint.	278,621.92	278,621.92	350,000.00	200,000.00		Reduced Allocation
8010	Capital Reserve GWE/Rate Stabilization	0.00	0.00	0.00	0.00	100.00%	Use not contribution
<b>TOTAL EXPENSES:</b>		<b>4,106,071.84</b>	<b>4,448,324.21</b>	<b>4,147,450.74</b>	<b>1,745,881.18</b>		8%
Operating Revenue		<b>4,527,961.52</b>	<b>4,893,265.65</b>	<b>4,756,011.78</b>	<b>1,744,188.33</b>		25%
<b>NET OPERATING REVENUE</b>		<b>421,889.69</b>	<b>444,941.44</b>	<b>608,561.04</b>	<b>-1,692.84</b>		

GL ACCT:                      GL DESCRIPTION:		Approved 2021-2022 Budget	Projected Annual Costs (7/1/21- 6/30/22)	Draft 2022- 2023 Budget	GROUNDWATER RECHARGE ENTERPRISE		
<b>Draft 2022-2023 Budget</b>					2021 BUDGET:	% BUDGET	BASIS:
<b>Multiyear Capital projects</b>							
7010	MATERIALS LAND & BUILDINGS	12,000.00	12,000.00	12,000.00	6,000.00	50.00% Field Security Changes	
7110	PROPERTY - CAPITAL REPAIRS	511,971.00	511,971.00	511,971.00	361,971.00	70.70% CIP #11 #15	
7120	PROPERTY - LAND PURCHASE	0.00	22,722.32	0.00			
7130	MENTONE PROPERTY (HOUSE) CAPITAL R	25,000.00	25,000.00	25,000.00	0.00		
7140	MENTONE PROPERTY (SHOP) CIP #3 b& c	375,000.00	330,000.00	375,000.00	375,000.00	100.00%	
7160	MENDOZA PROPERTY CIP\ #12 EQUIPMENT & VEHICLES	137,000.00	137,000.00	137,000.00			
7210	COMPUTER HARDWARE CAPITAL REPAIRS	5,000.00	5,000.00	5,000.00	1,250.00	25.00% Allocation basis 2011	
7220	COMPUTER SOFTWARE	10,000.00	20,000.00	10,000.00	3,000.00	30.00% Allocation basis 2011	
7230	FIELD EQUIPMENT / VEHICLES CIP #8 & #1	1,604.44	72,500.00	1,604.44	1,283.55	80.00%	
7240	OFFICE EQUIPMENT PROFESSIONAL SERVICES:	1,500.00	1,500.00	1,500.00	0.00		
7126	ARTP ENGR/PROF SERVICES #23 #31	500,000.00	500,000.00	500,000.00	0.00	0.00%	
7150	MILL CREEK DIVERSION PROJECT CIP #1	1,100,000.00	1,100,000.00	1,100,000.00	1,100,000.00	100.00% In WIP Acct until completion	
7438	ENGINEERING SERVICES-OTHER	125,000.00	125,000.00	125,000.00	20,000.00	16.00% Mill Creek O&M Plans	
<b>CAPITAL EXPENSE</b>		<b>2,804,075.44</b>	<b>2,862,693.32</b>	<b>2,804,075.44</b>	<b>1,868,504.55</b>		
CAPITAL REVENUE				350,000.00	200,000.00		
CAPITAL SUBTOTAL ANNUAL NET				-2,554,075.44	-1,668,504.55		
<b>RESERVE CONTRIBUTION OR (-USE)</b>			<b>TOTAL</b>	<b>-1,945,514.40</b>	<b>-1,670,197.39</b>	<b>Total Multi year Pay Go Capital Project</b>	

**RESOLUTION NO. 599**

**A RESOLUTION OF THE BOARD OF DIRECTORS OF THE  
SAN BERNARDINO VALLEY WATER CONSERVATION  
DISTRICT ESTABLISHING A GROUNDWATER CHARGE ON THE PRODUCTION OF  
GROUNDWATER WITHIN DISTRICT BOUNDARIES,  
AND MAKING CERTAIN FINDINGS RELATIVE THERETO FOR FISCAL YEAR 2022-2023**

**WHEREAS**, California Water Code, Division 21, Part 9 provides authority for the San Bernardino Valley Water Conservation District to consider and impose a groundwater charge on groundwater production within the District; and

**WHEREAS**, the California Legislature has found, in Water Code Section 75521, that such groundwater charges are in furtherance of District activities in the protection and augmentation of water supplies for users, which are necessary for the public health, welfare and safety; and

**WHEREAS**, Water Code Section 75523 allows for the use of proceeds from a groundwater charge for any District purposes, which may be authorized by law; and

**WHEREAS**, The District has presented a budget showing the needs and uses of the Groundwater Charge revenues for 2022-2023 water year; and

**WHEREAS**, at the regular meeting of the Board of Directors on March 09, 2022, the District accepted an Engineering Investigation report, relating to groundwater conditions in the Bunker Hill Basin underlying the District boundaries; and

**WHEREAS**, the Preliminary Groundwater Enterprise Budget and rate recommendations were presented to the Groundwater Council on January 27, 2022, and publicly reviewed at the District's Board meeting of February 9, 2022; and

**WHEREAS**, Certain Basin Producers, as well as the District, have formed a Groundwater Council ("GC"), and in connection with that Groundwater Council have entered into the San Bernardino Basin Groundwater Council Framework Agreement ("GC Agreement"), which includes regional cooperation among its member entities to perform an annual review of the needs for, and funding of, various maintenance costs for facilities used to replenish the Bunker Hill Basin, including facilities owned or managed by the District, pursuant to an agreed Equitable Allocation formula developed as part of the GC Agreement. The GC Agreement likewise includes a mechanism for contribution by its member entities toward procuring funds to secure additional imported water supplies for recharge of the Bunker Hill Basin, when such supplies are available, the costs of which are allocated pursuant to a replenishment/sustainability component cost-sharing structure, to recharge additional imported water purchased by the GC; and

**WHEREAS**, the California Supreme Court decision in the case of *City of San Buenaventura v. United Water Conservation District*; Case No. S226036 ("Ventura Decision") resolved previously outstanding legal issues relating to the procedures and constitutional requirements attending the levy and collection of groundwater charges under applicable authorizing statutes, pertaining to water conservation districts like the District; and

**WHEREAS**, under that opinion, the California Supreme Court clarified that such groundwater charges are not "property related charges" under California Constitution Article XIII D (Proposition 218), but did affirm that such charges are governed by California Constitution Article XIII C (Proposition 26), such that the charge must be set at a rate that in the aggregate is no more than is necessary to cover the reasonable costs of the governmental activity for which it is charged, and that the manner in which those costs are allocated to a payor bear a fair or reasonable relationship to the payor's burdens on, or benefits received from, the governmental activity; and

**WHEREAS**, the California Supreme Court's opinion in the Ventura Decision cast serious legal doubt on the continuing validity of the statutory differentials in groundwater charge rates provided under Water Code section 75594, which dictates that groundwater charges for non-agricultural uses be three to five times greater than agricultural uses; and

**WHEREAS**, the District in compliance with the procedural and constitutional requirements clarified by the California Supreme Court in the Ventura Decision, shifted its groundwater charge to eliminate differentials in agricultural and non-agricultural uses, having implemented a three-year rate stabilization mechanism to ease the transition of agricultural users, who historically paid lower per acre/foot rates, to a unitary rate that is more in line with current legal guidance; and

**WHEREAS**, the District provided mailed notice to all groundwater producers within its District boundaries of a public meeting held on April 13, 2022, and a public hearing held on April 27, 2022, inviting all groundwater producers and all persons interested in the condition of groundwater or surface water supplies of the District to appear and submit evidence, and inviting all water producers to examine the Engineering Investigation report; and

**WHEREAS**, the Board of Directors conducted a public meeting on April 13, 2022, and a public hearing on April 27, 2022, to receive comment and evidence submitted by the public at such hearing; and

**WHEREAS**, the District has made available by wide distribution, beginning on February 9, 2022, a Groundwater Enterprise Budget identifying the proposed use of the estimated Groundwater Charge proceeds, which will be subsequently incorporated in the District budget; and

**WHEREAS**, the Board has considered the Engineering Investigation report, applicable groundwater enterprise budgets, and considered all comments and evidence presented to it at the public meetings and hearings; and

**WHEREAS**, the District's ad valorem tax revenues are limited, and the District receives relatively low return in the way of interest on reserves; and

**WHEREAS**, on the basis of all evidence presented, including the Engineering Investigation report and such public comment, the Board has determined that it is appropriate and in the best interests of the District and all those water users who rely, directly or indirectly, on the District's services, to levy a groundwater charge as further provided herein; and

**WHEREAS**, pursuant to a request received from the GC, the District is including within its groundwater charge for the 2022-2023 cycle a Replenishment/Sustainability component, to be imposed on entities subject to the District's Groundwater Charge that are not members of the GC. This Replenishment/Sustainability component is designed to assure that all users of the Bunker Hill Basin who profit from not only the maintenance and operation by the District of groundwater recharge facilities serving the Bunker Hill Basin, but also the acquisition and application to basin recharge of imported water supplies funded and secured through the auspices of the GC, contribute ratably, proportionately to those contributions of the members of the GC, toward such efforts, which efforts inure to the benefit of the basin as a whole, and each of its users who benefit from the GC water supply enhancement efforts. The GC supports phasing in this charge over several years; and

**WHEREAS**, the amount of the proportionate share of non-Groundwater Council member sustainability requirements, and its cost, have been derived from the application of the Equitable Allocation Model utilized by the GC, which takes the production of producers (or their predecessors) over the Base Period of 1959-1963, and the rolling most recent five-year period, (currently 2016-2020), to weight evenly the considerations of the exercise of historical rights and current production patterns, for the purposes of assigning the costs of imported basin recharge enhancement by the GC, at the imported water rate of \$118.40/af. For non-Groundwater Council members within the District's boundaries, this results in 807 acre feet of sustainability need, which amounts to a total water cost of \$95,554. Per the Western Judgment Watermaster, this group of non-Groundwater Council members' production for 2020 was a total of 5,203 acre feet. To assign a per acre foot rate of sustainability cost to actual production, the \$95,554 cost is divided by 2020 actual production from such users, yielding a per acre rate of \$18.37; and

**WHEREAS**, based on this calculation, the Replenishment/Sustainability component charge is \$18.37 per acre foot. Because this represents a substantial one-time increase compared to prior District groundwater charges, this rate component is proposed to be phased in over a five-year period, increasing 20% per year until the \$18.37 acre foot amount is achieved, in order to allow for transition of payment and budgeting for affected users. As such, the proposed initial phase-in amount of such charge component is \$7.35 per acre foot to be applicable to the current year's groundwater charge. This amount will be revisited yearly, since groundwater charges are established annually, but the current intention is to have the Replenishment/Sustainability Component increase by one-fifth each year, until the full proportionate rate of \$18.37 is achieved; and

**WHEREAS**, the \$18.37 per acre foot figure is proportional to the benefit received by non-Groundwater Council members, because it is derived from the amount of production in 2020 of those non Groundwater Council members within the District's jurisdiction of 5203 acre feet, which when divided by the total Equitable Allocation sustainability need attributable to such users, at 807 acre feet and a total cost of \$95,554, yields a per acre foot amount of \$18.37; and

**WHEREAS**, the Replenishment/Sustainability charge component will not be assessed or collected from those Riverside County producers who extract water from the basin directly under the rights adjudicated in the Western Judgment, *Western Municipal Water District of Riverside County et al. v. East San Bernardino County Water District et al.*, Riverside County Superior Court Case No. 78426, because under that judgment, the allocation of production rights of such users from the basin are fixed, and does not vary with enhanced supplies contributed by the GC or those acting in concert with it. In addition, because to the extent such users are themselves contractors under the State Water Project, and because the GC's enhanced supplies are secured from the San Bernardino Valley Municipal Water District's State Water Project allocation, such users are contractually precluded from State Water Project purchases from any State Water Project contractor other than their own, and as such, these users do not receive proportionate benefit from the GC's imported water supply enhancement activities.

**NOW, THEREFORE, BE IT RESOLVED BY THE BOARD OF DIRECTORS OF THE SAN BERNARDINO VALLEY WATER CONSERVATION DISTRICT AS FOLLOWS:**

Section 1. As required by Water Code Section 75574, the Board hereby makes the following findings:

- A. Annual Change in Storage in those portions of the Bunker Hill Basin lying within the District's boundaries ("Bunker Hill Basin" herein), Fall 2020 to Fall 2021, is a decrease of 93,846 acre-feet or more.
- B. Accumulated Change in Storage in the Bunker Hill Basin as of the Last Day of the Preceding Water Year (using 1993 as base year) is -580,031 acre-feet or more.
- C. Total Groundwater Production from the Bunker Hill Basin from the Preceding Water Year July 1, 2020 to June 30, 2021 is 173,171 acre-feet.
- D. Estimate of the Annual Change in Storage for the Current Water Year (July 1, 2021 to June 30, 2022) in the Bunker Hill Basin is -79,759 acre-feet or more.
- E. Estimate of the Annual Change in Storage for the Ensuing Water Year (July 1, 2022 to June 30, 2023) in the Bunker Hill Basin is -5,943 acre-feet.
- F. Average Annual Change in Storage for the Immediate Past Ten Water Years in the Bunker Hill Basin is -32,822 acre-feet or more.
- G. Estimated Amount of Agricultural Water Withdrawn from the Groundwater Supplies of the District for the Ensuing Water Year (July 1, 2022 to June 30, 2023) is 9,503 acre-feet.
- H. Estimated Amount of Other-than-Agricultural Water Withdrawn from the Groundwater Supplies of the District for the Ensuing Water Year (July 1, 2022 to June 30, 2023) is 95,690 acre-feet.
- I. Estimated Amount of Water Necessary for Surface Distribution for the Ensuing Water Year (July 1, 2022 - June 30, 2023) within the Bunker Hill Basin is 77,235 acre-feet.
- J. Estimated Amount of Water Necessary for Surface Distribution for the Ensuing Water Year (July 1, 2022 - June 30, 2023) for the District is 54,552 acre-feet.
- K. The Amount of Water which is Necessary for the Replenishment of the Groundwater Supplies of the Bunker Hill Basin to maintain constant groundwater supplies for the Ensuing Water Year (July 1, 2022 to June 30, 2023) is 131,381 acre-feet.
- L. The Amount of Water which is necessary from all sources, including natural recharge to bring the basin back to its "full" condition of 1993 is 791,171 acre-feet.

Section 2. The Board of Directors hereby finds that the entire District constitutes a single zone of benefit for the imposition of this charge. The basis for this finding is that the entire portion of the basin underlying the District boundary is fed by the same naturally occurring surface flows. Although the basin may be divided into various subparts, because of hydrogeological conditions these areas are interconnected, and water recharged by the District from its existing recharge facilities contributes to underground "flows" which eventually reach other subparts of the basin. Thus, the District's recharge inures to the benefit of users in other areas by enhancing the availability of water supplies throughout the basin. In addition, the District maintains both the availability of surface water flows for groundwater recharge, and the facilities for accommodating the recharge, whether by the District or by other parties pursuant to collaborative regional groundwater management efforts. The District likewise undertakes habitat enhancement and preservation measures, providing an important source of offsetting mitigation land for disturbances occasioned by the maintenance of existing groundwater recharge facilities, and the development of new ones.

Section 3. The Board finds that there is no past accumulation of the amount of water necessary to be replaced in the intake areas of the groundwater basins within the District to prevent the landward movement of salt water into the fresh groundwater body, or to prevent subsidence of the land within the District, either in the past water year or the proceeding 10 years, nor is there likely to be any amount of water necessary for these purposes in the ensuing water year. The Board further finds that the District is not obligated by contract to purchase any water, though depending on the decision-making processes of the GC, the District may be asked to help fund regional purchases of imported water to augment native water supplies. The Board also finds that further recharge of the basin is required based upon the findings related to change in storage stated in Section 1 above, to prevent depletion or degradation to the basin's groundwater supplies, to enhance both the availability and accessibility of such supplies, and to replenish, augment, and protect such supplies, and that the proceeds of the groundwater charge established herein shall be used for such purposes.

Section 4. The Board of Directors hereby levies, assesses and affixes a groundwater charge in the amount of \$15.27 per acre foot of water produced, to be applicable to all production (agricultural and non-agricultural use). The Board imposes this unitary rate in response to, and in an attempt to comply with, the Ventura

Decision, but also because the District has not historically segregated either facilities or groundwater charge-funded efforts based on agricultural vs. non-agricultural use basis. Nor has the District undertaken studies to isolate a predominantly agricultural producing zone or region within the District boundaries, and even if such an area were to be isolated, there is some question based on existing facts and circumstances whether the benefits and burdens of the District's groundwater management and replenishment services could support a rate differential based on agricultural use. The Board of Directors likewise hereby levies, assesses and affixes a Replenishment/Sustainability component of groundwater charge in the amount of \$7.35 per acre foot of water produced, to be applicable to all production (agricultural and non-agricultural use) by users within the Bunker Hill Basin who are not GC members. Late charges on delinquent accounts will be 1% interest per month in accordance with Water Code §75615 et seq. and any additional actual costs to collect delinquent amounts not paid by August 1, 2022 and February 1, 2023.

Section 5. Exemptions:

A. Notwithstanding the foregoing, for producers who can demonstrate that their production for the water year is restricted to basic, personal residential use limited to the property on which the applicable groundwater production facility is based, and the total cumulative production for the applicable producer within the District is not in excess of two (2) acre feet over the course of the water year; such production shall be exempted from the groundwater charge provided the producer documents its exemption prior to semi-annual collection of the groundwater charge. In establishing this exemption, the Board finds that the likely revenues to be derived from the groundwater production subject to the exemption is outweighed by the administrative burdens in administering and collecting the charge. The District General Manager is authorized to waive late fees with explanation and request from payees or if the cost of recovery outweighs the fee to be collected.

B.

(1). To the extent that a party who is a member of the GC has paid a maintenance and operation charge through the Equitable Allocation based upon an approved budget for the GC that includes the maintenance and operations costs reflected in the District's budget showing the needs and uses of the groundwater charge for 2022-2023 water year, and such payment is remitted to the District, the General Manager is authorized to accept such Equitable Allocation payment as payment in full for the non-Replenishment/Sustainability component of groundwater charges due from that party's production for the applicable water year. If a GC member remits its Equitable Allocation for maintenance and operation costs to the District, but in that same water year leaves or otherwise ceases to participate in the GC, the District's then-current groundwater charges shall apply to such party's production for the entire water year, and that party's amount of the Equitable Allocation so remitted will be used as a prepayment offset for groundwater charges otherwise due from such party's production. The purpose for this credit is to assure that parties contributing to the maintenance and operations component of the GC Equitable Allocation do not double-pay for their proportionate cost of the District's services.

(2). To the extent that a party who is a member of the GC has paid a contribution for groundwater replenishment/sustainability through the Equitable Allocation based upon an approved budget for the GC that includes the purchase of imported water supplies for replenishment of the basin for 2022-2023 water year, and such payment is remitted to the GC, the General Manager is authorized to credit such Equitable Allocation payment as payment in full for the Replenishment/Sustainability component of groundwater charges due from that party's production for the applicable water year. If a GC member remits its Equitable Allocation for replenishment/sustainability to the GC, but in that same water year leaves or otherwise ceases to participate in the GC, the District's then-current groundwater charges shall apply to such party's production for the entire water year, and that party's amount of the Equitable Allocation apportioned to the GC's replenishment/sustainability activities so remitted will be used as a prepayment offset for the Replenishment/ Sustainability component of groundwater charges otherwise due from such party's production. The purpose for this credit is to assure that parties contributing to the GC's replenishment/sustainability component of the GC Equitable Allocation do not double-pay for their proportionate share of such efforts.

C. The District has been in discussions with various Riverside County entities who propose to be Ex Officio members of the GC, and who may, by separate agreement with the District, agree to fund portions of the maintenance and operations costs of existing recharge facilities. To the extent such an agreement is reached, and a party otherwise subject to the District's groundwater charge contributes in such a way this its payment is remitted to the District; the General Manager is authorized to provide discharges and credits to such Ex Officio members in the same manner as for Groundwater Council members, provided above. The purpose for this credit is to assure that parties contributing to the maintenance and operations of the District through any such agreement do not double-pay for their proportionate cost of the District's services.

Section 6. In connection with fixing the groundwater charge as set forth in Section 4 above, the Board of Directors makes the following findings:

- A. Consistent with the Ventura Decision, the District’s groundwater charge is not a “property-related charge” for purposes of determining the applicability of Article XIII D of the California Constitution. Notwithstanding, the District has provided mailed notice of the proposed charge and the amounts proposed to be charged to all known groundwater producers within its jurisdictional boundaries, on February 23, 2022.
- B. The groundwater charge is imposed upon the action of extraction of groundwater from the basin underlying the District’s boundaries, and not on property or groundwater extraction facilities as such. The groundwater charge will be incurred by groundwater producers through their voluntary action of groundwater production. The groundwater charge is not one for water delivery by the District to groundwater extractors, but rather relates to the District’s service of maintaining groundwater supplies, recharge facilities, and management of both for groundwater extractors within the District. The District maintains no pipes, canals or other facilities directly connecting District facilities to the groundwater extractors’ property or pumping facilities. In addition, parties subject to the groundwater charge are predominantly either public or private entities involved in the business of providing water, or persons or entities involved in irrigation, for agricultural-related activities, and for uses of water exceeding what would be required for basic residential use of the property.
- C. The District has provided notice of the proposal for imposition of the groundwater charge through a number of different avenues. Mailed notice was provided to all operators reflected on the District’s records as containing active groundwater production facilities within the District. In addition, published notice was provided in the San Bernardino Sun and in the Highland Community News on March 4, 11 and 18, 2022. All such notices identified the prior and proposed rates, the estimated total revenue to be collected from the charge, and the time and place for public hearing at a public meeting at which parties objecting to the charge could appear and be heard. That notice also reflected the rate and method of calculation for this consumption-based charge, which provided notice of the basis of the charge.
- D. The proposed groundwater charges, and Engineering Investigation report prepared by the District, were reviewed at a public meeting held April 13, 2022, and a public hearing held April 27, 2022. In addition, the Engineering Investigation report prepared by the District was presented to and reviewed with the Board of Directors at a public meeting on February 9, 2022 was discussed at the Groundwater Council on February 14, 2022, and was approved by the District’s Board on March 9, 2022.
- E. The groundwater charge is being levied to assist in offsetting the costs of the District’s Groundwater Enterprise in providing groundwater supplies, groundwater recharge facilities, and recharge management and administration for the benefit of groundwater producers within the District. The Groundwater Enterprise Budget includes, but is not limited to, funding the following:
  - 1. Making available the District’s Santa Ana River water rights, in an amount no less than 10,400 acre per feet per year, for recharge into the Bunker Hill Basin;
  - 2. Conducting groundwater recharge activities by diverting both Santa Ana River and Mill Creek water supplies into District’s recharge facilities;
  - 3. Applying the District’s experience and expertise in directing groundwater recharge effectively and efficiently, administering the physical recharge of groundwater both directly for the District and its water supplies, and recharging on behalf of other entities, including State Project Water and exchanges under the Santa Ana River/Mill Creek Cooperative Water Project Agreement;
  - 4. Maintaining and operating the District’s diversion works, recharge basins and canals to ensure the availability of sufficient infrastructure to accommodate needed groundwater recharge; and defense and protection of the District’s water rights and manner of operations; and performing such maintenance of other parties’ diversion works, recharge basins and canals as requested and per prior agreements.
  - 5. Pursuing various environmental permits and related permissions to continue the maintenance and operation of the District’s Facilities for the future and to provide for potential expansion of facilities for Bunker Hill Basin recharge, including the preservation, enhancement, and management of habitat areas;
  - 6. Investigation and implementation of improvements to groundwater measurement and recharge infrastructure;

7. Reporting to groundwater producers and other interested parties of groundwater recharge activities and conditions, including but not limited to the daily flow report;
  8. Conducting engineering analyses, such as the District's annual Engineering Investigation, designed to provide information regarding the Bunker Hill groundwater basin and the District's groundwater recharge facilities;
  9. Participating in, and serving as the accounting arm for the collection of, both facilities maintenance and operations funds and contributions for the GC; and Replenishment/Sustainability funds, for proportionate contribution to import water supply efforts by producers who are not members of the Groundwater Council, but who still benefit from the regional efforts at maintaining Bunker Hill Basin groundwater supplies;
  10. Administrative support, training and overhead for all the above-listed activities.
- F. The total amount of estimated revenues from the groundwater charge, including the Replenishment/Sustainability component, is estimated at approximately \$1,488,360 based on production reported for the 2021-2022 water year. This amount does not consider offsets as provided in Section 5(b)(1) and (2) above for GC members. The specific total amount of groundwater charge revenues from non-GC members cannot be accurately stated at this time, because the amount of credits for GC member Equitable Allocations are dependent on yearly budgeting by the GC. Based on the last year's Equitable Allocation determinations, however, applied to production from the 2021-2022 water year from non-GC members, the estimated groundwater revenues from non-GC members is \$95,554. These revenues do not fully recover expected cost and will not exceed the costs of providing the services as detailed above, in that the District's Groundwater Enterprise Budget for fiscal year 2022-2023 proposes total expenditures of \$1,737,023. The remaining funds are to be paid by the District's capital and groundwater reserves, lease payments from Valley District and Western and Exchange Plan management reimbursements.
- G. The amount of groundwater charge paid by each individual payor will not exceed the benefit of the Conservation District's services to such parties, because the structure of the groundwater charge is such that the amount paid varies in direct proportion to the amount of groundwater supplies extracted, and therefore is proportional to the benefit each individual payor receives from the District's services, and the burden each producer puts on the basin, ratably to such user's production.

**Section 7.** Notwithstanding Water Code Section 75523, and to assure the proportionate benefit of the Replenishment/Sustainability charge between those who pay it and those who are members of the Groundwater Council, all revenues collected by the District from the Replenishment/Sustainability component will be separately accounted for and maintained in a discrete fund by the District, and shall not be commingled with any other District funds or revenues. The proceeds of such Replenishment/Sustainability charge shall be devoted and applied exclusively to Bunker Hill Basin maintenance and water supply enhancement efforts in conjunction with the Groundwater Council, whether by way of direct payment to the Groundwater Council in connection with such efforts, or as directly applied by the District in cooperation with the Groundwater Council toward such efforts.

**Section 8.** The Board of Directors further finds that the groundwater charge adopted herein is statutorily exempt from CEQA under Title 14, California Code of Regulations Sections 15273, 15301, and 15306. The action contemplated herein constitutes a structuring and establishment of a charge which will be used in part for meeting operating expenses and for purchasing or leasing equipment and materials. To the extent the groundwater charge revenues will be applied to groundwater testing, these activities fit within Title 14, California Code of Regulations Section 15306. Such activities involve the occasional taking of groundwater samples by means of temporary equipment, which will not cause any alteration to the land, and consist solely of information gathering. To the extent any portion of the funds is directed to maintenance, operation, or repair of existing facilities, involving no or negligible expansion of existing uses, these activities fit within Title 14, California Code of Regulations Section 15301. To the extent any portion of the funds is directed to construction or establishment of new facilities, environmental review of such facilities will occur at such time those facilities are proposed, and the nature, location, scope, and function of such potential future facilities becomes known. Under each of the above-referenced exemptions, therefore, the Board of Directors finds that the levy and implementation of the groundwater charge is properly exempt from CEQA.

**Section 8.** The General Manager is hereby authorized and directed to provide notice to operators of the levy of the groundwater charge, as provided for in Water Code Section 75610.

PASSED, APPROVED AND ADOPTED at a regular meeting of the Board of Directors this 27<sup>th</sup> day of April 2022, by the following roll-call vote:

YES:  
NO:  
ABSTAIN:  
ABSENT:  
ATTEST:

DIRECTORS:  
DIRECTORS:  
DIRECTORS:  
DIRECTORS:

---

Melody McDonald, President

---

Daniel Cozad, Secretary

SAN BERNARDINO VALLEY WATER CONSERVATION DISTRICT  
BOARD OF DIRECTORS MEETING

MINUTES OF MARCH 9, 2022  
1:30 p.m.

President McDonald called the Board of Directors meeting to order at 1:30 p.m. by in-person, teleconference, and Zoom meeting. Mr. Cosgrove reviewed the procedures in which the hybrid meeting would proceed, and noted that President McDonald is attending via Zoom from the location that is the secondary location listed on the agenda and is accessible to the public. All those in attendance stood for the pledge of allegiance led by President McDonald.

ROLL CALL:

BOARD MEMBERS PRESENT:

Melody McDonald, President  
Richard Corneille, Vice President  
Robert Stewart, Director  
David E. Raley, Director

BOARD MEMBERS ABSENT:

John Longville, Director

GENERAL COUNSEL PRESENT:

David Cosgrove, District Counsel

STAFF PRESENT:

Daniel Cozad, General Manager  
Betsy Miller, Land Resources Manager/Assistant General Manager  
Milan Mitrovich, Land Resources Manager  
Erwin Fogerson, Senior Engineer/Project Manager  
Katelyn Scholte, Assistant Engineer  
Angie Quiroga, Administrative Analyst  
Anna Frey, Intern  
Jazmin Serrato, Intern

GUESTS PRESENT:

T. Milford Harrison, San Bernardino Valley Municipal Water District  
June Hayes, San Bernardino Valley Municipal Water District  
Paul Kielhold, San Bernardino Valley Municipal Water District  
Willow Green, Tetra Tech  
David E. Smith, East Valley Water District

1. PUBLIC PARTICIPATION

President McDonald announced that any persons present, who so desired, may make an oral presentation to the Board of Directors. There being none, the meeting continued with the posted agenda items.

2. ADDITIONS/DELETIONS TO AGENDA

There were none.

3. GUEST RECOGNITIONS/SELF INTRODUCTIONS

Ms. Miller introduced staff present and the guests listed above introduced themselves.

4. AD HOC COMMITTEE APPOINTMENTS

President McDonald appointed Vice President Corneille and Director Raley to the Ad Hoc Audit Committee.

5. PUBLIC HEARING RELATED TO REDISTRICTING

Mr. Cosgrove indicated that this is the second public hearing with respect to redistricting. The District has been reviewing the 2020 census, per Election Code section 22001, in order to realign the Districts' division boundaries based on data from the 2020 census. In January and February, the Board reviewed various division scenarios updated to reflect changes in population and provided direction to staff to provide additional scenarios with certain refinements. Today's presentation included scenarios three through seven for public review and comment. The associated Board memo and updated scenarios on package page 7 were reviewed and discussed. Mr. Cosgrove reviewed the criteria defined by the statute that must be considered during the redistricting process. Resolution No. 597 was shown on package page 21 for review and approval to adopt a final scenario. All scenarios and information have been posted on the District website for public review. At this time, staff has not received any public comment for consideration. Staff recommends the Board approve Scenario 7 as the District's realigned boundaries, and open the public hearing and take any comment. If there is no public comment, staff recommends approval of the resolution as presented. Mr. Cosgrove noted that once a scenario is approved, legal descriptions will be submitted to the Registrar of Voters as noted in Section 2 of the resolution.

President McDonald opened the public hearing. She asked if any public wished to comment on the scenarios presented and information provided, and thanked Ms. Frey for her efforts on the redistricting project. Mr. Cosgrove noted that no public comment was received. There being no public comment or testimony, President McDonald closed the public hearing.

Vice President Corneille spoke in regard to the population discrepancy between divisions, and asked staff if it was possible to have more similar population numbers between the scenarios. Ms. Frey indicated that the scenarios reflect that most similar population numbers possible while incorporating the suggestions received from the Board. Mr. Cosgrove noted that the variance is within the legal limits set by the election code. Vice President Corneille prefers Scenario 4, but if it the consensus of the Board he will support Scenario 7. He said that Divisions 1 and 2 are now switched and asked if it would make a difference referring to elections. Mr. Cosgrove discussed the legal criteria for divisions and indicated that Scenario 7 is within the legal parameters. Director Stewart spoke in support of Scenario 7, and thanked Ms. Frey for her efforts.

**It was moved by Vice President Corneille and seconded by Director Raley to adopt Scenario 7 and Resolution No. 597. The motion carried 4-0, with all Board members present voting in the affirmative. Director Longville was absent from the vote.**

**President McDonald: Yes  
Vice President Corneille: Yes  
Director Longville: Absent  
Director Raley: Yes  
Director Stewart: Yes**

**6. CONSENT CALENDAR**

**It was moved by Vice President Corneille and seconded by Director Raley to approve the Consent Calendar: Item A: Special Board Minutes, February 2, 2022; Item B: Board Minutes, February 9, 2022; Item C: Expenditure Report, February 2022; and Item D: Resolution No. 598 Remote Meetings Per AB 361. The motion carried 4-0, with all Board members present voting in the affirmative. Director Longville was absent from the vote.**

**President McDonald: Yes  
Vice President Corneille: Yes  
Director Longville: Absent  
Director Raley: Yes  
Director Stewart: Yes**

**7. COMMITTEE REPORTS/ACTION ITEMS**

**A. UNAUDITED FINANCIAL REPORT, FEBRUARY 2022**

Ms. Miller introduced this item for discussion, noting its inclusion on package page 47. She indicated that the interest income continues to be below budget due to market factors and the larger numbers associated with the Wash Plan are for state and waters permitting fees, permitting repayments from Wash Plan Task Force members, and Wash Plan implementation expenses. There are slightly higher expenses for Redlands Plaza due to higher maintenance costs and under General Administration related to onboarding staff. Director Stewart asked if the revenue for GL 4025 Wash Plan Revenue was for the prior budget year or multiple budget years. Mr. Cozad said that the District is advancing funds to the Wash Plan for the completion of permitting, and then the District will receive repayment. This is for internal tracking purposes. Vice President Corneille asked for clarification regarding groundwater revenue allocations. Mr. Cozad indicated that next year this will change and there will only be two revenue allocations for the groundwater revenue. Vice President Corneille asked why the permitting seems to be overbudget. Mr. Cozad said that these are Wash Plan permit preparation and application costs, but the actual annual reoccurring permitting costs are unknown at this time until the permits are actually received. Ms. Miller noted that the Mill Creek permitting costs will be budgeted more closely due to the project being more straightforward than the Wash Plan permits. Director Raley inquired about the negative interest income. Ms. Miller indicated that GL 4010 reflects unrealized losses on investments.

**It was moved by Director Raley and seconded by Director Stewart to approve the Unaudited Financial Reports from February 2022. The motion carried 4-0, with all Board members present voting in the affirmative. Director Longville was noted absent from the vote.**

**President McDonald: Yes**  
**Vice President Corneille: Yes**  
**Director Longville: Absent**  
**Director Raley: Yes**  
**Director Stewart: Yes**

B. GROUNDWATER LATE PAYER, NON-RESPONDENTS AND INVESTIGATION LIST FOR GWA #57

This item was included on package page 53. Mr. Cozad stated that Lucky Farms needs additional investigation. All the other entities listed are typically late, and thus are expected to pay. It is believed that Lucky Farms may have changed ownership. President McDonald inquired about the process for removing entities from the list if land ownership has changed or the well is not operational. Mr. Cozad indicated that the well owner has to obtain documentation from the County that the well has been abandoned or destroyed and submit it to the District. As long as the well is still there, reporting is required. Mr. Cozad said that the District does not want wells just left behind because they can contaminate groundwater.

**It was moved by Director Stewart and seconded by Vice President Corneille to direct staff to continue investigate Lucky Farms. The motion carried 4-0, with all Board members present voting in the affirmative. Director Longville was noted absent from the vote.**

**President McDonald: Yes**  
**Vice President Corneille: Yes**  
**Director Longville: Absent**  
**Director Raley: Yes**  
**Director Stewart: Yes**

C. FINAL 2022 ENGINEERING INVESTIGATION REPORT

Ms. Scholte presented this item for discussion, noting its inclusion beginning package page 55. She indicated that data have been received from three agencies since the draft was reviewed and presented at the February 9 Board meeting. She reviewed the changes to the draft: Task 1: decrease of 93,846 AF; Task 2: decrease of 580,031 AF from 1993; and Task 3: 173,171 AF for Groundwater Production within the Bunker Bill Basin. The basin is 791,171 AF from full as indicated in Task 9. Director Stewart asked what the level of accuracy is today versus ten to twenty years ago. Ms. Scholte indicated that the level of accuracy is expected to be the same because we continue to follow the same methodology for preparing the estimates. Director Raley asked if groundwater usage and recharge has increased. Ms. Scholte stated that it depends on the year: this year production has increased and groundwater recharge has decreased. She said that usage over the last several years may have been affected by mandated drought restrictions.

**It was moved by Vice President Corneille and seconded by Director Stewart to approve the Final 2022 Engineering Investigation Report. The motion carried 4-0, with all Board members present voting in the affirmative. Director Longville was noted absent from the vote.**

**President McDonald: Yes**  
**Vice President Corneille: Yes**

**Director Longville: Absent**  
**Director Raley: Yes**  
**Director Stewart: Yes**

D. AMENDMENT 2 TO THE MILL CREEK GROUNDWATER RECHARGE FACILITY OPERATIONS & MAINTENANCE PERMITTING PROFESSIONAL SERVICES CONTRACT AWARD

Ms. Miller introduced this item for discussion, noting its inclusion beginning on package page 70. This represents the third review of this item by the Board, including the original contract approved in November 2021 in the amount of \$250,186. At that time, it was understood that significant additional work may be required by the regulatory agencies, and addition of additional tasks would be subject to Board approval. At their February 9 meeting, the Board approved Amendment 1 – Task 3f to conduct a long-term wetland study. AECOM has conducted an in-depth site assessment of the Mill Creek groundwater recharge facility. The findings from this field analysis were discussed in brief. Staff is requesting approval to expend an additional \$68,282.50 to cover Task 1c, Task 1d and Task 11 as listed on package page 71. Task 11 was planned to be completed under a separate contract, but the consultant initially utilized for that project is no longer available; therefore, staff is requesting the Board incorporate this work into the AECOM contract. Mr. Cozad indicated that Task 11 is included on the existing Capital Improvement Project list, and is separate from the diversion. Director Stewart asked the general process if any endangered species are found within the project areas. Ms. Miller said that staff does not anticipate finding significant impacts from our existing operations to those species since the Mill Creek facilities have been in existence for quite some time, and the species have been coexisting there. This study is to identify the extent to which any impacts are possible. It is possible that some indirect effects may occur, but mitigation associated with indirect effects would be expected to be lower than that for direct effects. Vice President Corneille confirmed that this permitting is for existing Mill Creek facilities. He said that the District will be expanding these facilities under the Active Recharge Transfer Projects (ARTP) and asked if it would require additional analysis. Ms. Miller confirmed that additional analysis will be needed for the Mill Creek project under ARTP, and that any permits needed for the work would be obtained by Valley Municipal per the ARTP Partnership Agreement. Vice President Corneille requested that the memos for future contract amendments include the original contract amount and each amendment amount listed separately for clarity.

**It was moved by Director Raley and seconded by Vice President Corneille to authorize the General Manager to amend the Mill Creek Groundwater Recharge Facility Operations and Maintenance Permitting Professional Services Contract to include Optional Task 1c, Optional Task 1d and New Task 11, not to exceed \$63,282.50. The motion carried 4-0, with all Board members present voting in the affirmative. Director Longville was noted absent from the vote.**

**President McDonald: Yes**  
**Vice President Corneille: Yes**  
**Director Longville: Absent**  
**Director Raley: Yes**  
**Director Stewart: Yes**

E. MILL, BLEDSOE AND COOK CREEK PRELIMINARY ENGINEERING AND FEASIBILITY STUDY SUPPORT PROFESSIONAL SERVICES AWARD OF CONTRACT

Mr. Fogerson introduced this item for discussion, noting its inclusion on package page 75. The package includes the staff report, the detailed scope of work, project schedule, cost breakdown by task and proposed agreement with Q3 Consulting. He noted that the RFP was not included in the package. Unlike the previous ARTP feasibility study contracts approved by the Board, this item includes preliminary design. Mr. Fogerson said that this study will evaluate the Mill Creek system and will help identify potential improvements. The contract includes work on Mill Creek along with potential work on Bledsoe Creek and Cook Creek. Ms. Scholte said that Bledsoe and Cook Creek are options to replace City Creek listed under ARTP. She said that due to the instability of City Creek and the land being the location included in the Flood Control mitigation strategy it was not an option. Therefore, staff is evaluating other possible locations for recharge. This is not in the MOU with Flood Control, but it will be analyzed using the same parameters. Ms. Scholte said that the contract includes preliminary design and modeling for understanding current function and optimizing future operations of sixty-six basins at Mill Creek. Vice President Corneille asked for additional information on Bledsoe and Cook Creek. Mr. Fogerson said that additional details on these projects will be brought forward to the Operations Committee and ARTP Policy Committee. Vice President Corneille stated that there seems to be flexibility within the contract to allow one or more of these projects to be halted if they prove to be unfeasible following initial investigation. Discussion ensued. Vice President Corneille said that it is a very impressive and detailed scope of work and is supportive of the agreement. Director Stewart asked who would lead maintenance if it is conducted by an entity besides the District. Ms. Scholte said that maintenance related to groundwater recharge will be led by the Conservation District and maintenance related to flood control will be led by Flood Control. The next step is preparation of a water spreading agreement. Mr. Cozad said all of these projects are good for water conservation, flood control and for the community. Director Stewart asked what the goal is. Mr. Fogerson said that the consultant is providing back up data and analysis. The District is doing the feasibility study so that it can decide which sites are actually feasible. Director Stewart asked if a map of the ARTP project proposed sites could be included for reference. He also spoke highly of the scope of work presented. President McDonald thanked the Board and staff.

**It was moved by Director Raley and seconded by Director Stewart to find the contract to be categorically exempt from CEQA under Title 14, California Code of Regulations Sections 15306, and statutorily exempt under Section 15262; accept the Q3 proposal; and authorize the General Manager and General Counsel to complete the negotiation of services and fees and execute a professional consultant services agreement not to exceed \$2,190,644. The motion carried 4-0, with all Board members present voting in the affirmative. Director Longville was noted absent from the vote.**

**President McDonald: Yes  
Vice President Corneille: Yes  
Director Longville: Absent  
Director Raley: Yes  
Director Stewart: Yes**

F. FOGERSON RETIRED ANNUITANT POSITION

This item was included on package pages 111 to 117. Mr. Cosgrove said that at the February 9 meeting this position was approved for Mr. Fogerson, who will retire on March 31. In connection with that decision, the required CalPERS resolution and agreement requirements were prepared. Vice President Corneille asked if medical benefits are included. Mr. Cosgrove indicated that they are statutorily not allowed, so

they are not included within the agreement and resolution. Vice President Corneille thanked Mr. Fogerson for agreeing to return as a retired annuitant and for his great work thus far. President McDonald said that the Board is very grateful for his expertise and for his continued support of the District.

**It was moved by Vice President Corneille and seconded by Director Stewart to approve Resolution No. 600, and the agreement for employment of the Active Recharge Transfer Project engineer, Erwin Fogerson, as retirement annuitant. The motion carried 4-0, with all Board members present voting in the affirmative. Director Longville was noted absent from the vote.**

**President McDonald: Yes  
Vice President Corneille: Yes  
Director Longville: Absent  
Director Raley: Yes  
Director Stewart: Yes**

G. ANNUAL REPORT ON THE STATUS OF THE SAN BERNARDINO VALLEY CONSERVATION TRUST

Mr. Cozad introduced this item for discussion, noting its inclusion on package page 118. He presented a PowerPoint slide deck. These materials are an update to the first status report, which was presented last year. The Conservation Trust was developed to hold conservation easements and associated endowments for the Wash Plan and for appropriate non-Wash Plan mitigation. The Conservation Trust has a complete set of current policies including investment, reserve, conflicts of interest, records, endowment spending and amendment of conservation easements. The current Board of Directors for the Conservation Trust are David Raley, John Longville, T. Milford Harrison, and Jim Earsom of IERCD, who recently assumed the role. Mr. Cozad continued his PowerPoint presentation, noting the relationship between the Trust and the District. He reviewed the investment differences and the community mitigation program and participants. The 2020-2021 Audit Statement summary table was shown on package pages 130 to 131. There was an early agreement with Valley Municipal, the District negotiated some acreage to offset impacts for the Enhanced Recharge project to plus up the mitigation for that project. There is \$650,000 worth of conservation easements the District provided through the Wash Plan to Valley Municipal. Vice President Corneille asked for details on donor restrictions. Mr. Cozad indicated that the endowment is essentially a donor restriction. He reviewed the investment policy and net position. US Bank is the depository entity for investments, managed by PFM. Accounts receivable is the miners' portion of the endowment. Their endowment contribution will be paid when they request certificates of inclusion to mine areas permitted by the Wash Plan. The Wash Plan budget was reviewed. This item was received and filed.

**It was moved by Director Raley and seconded by Director Stewart to receive and file the Annual Report on the Status of the San Bernardino Valley Conservation Trust. The motion carried 4-0 with all present voting in the affirmative. Director Longville was noted absent from the vote.**

**President McDonald: Yes  
Vice President Corneille: Yes  
Director Longville: Absent  
Director Raley: Yes  
Director Stewart: Yes**

H. LAFCO SPECIAL DISTRICTS SELECTION COMMITTEE REQUESTS FOR SUPPORT

Mr. Cozad introduced this item for discussion, noting its inclusion on package page 136. He said that at the last Board meeting, the Board nominated Director Raley for the alternate seat on the LAFCO Special Districts Selection Committee (Committee). The regular special district member nominees are Steven Farrell and Kelly Gregg. The alternate regular special district member nominees are Craig Dicht, Kevin Kenly, David Raley and James Roberts. President McDonald recommended Kelly Gregg for the position as the regular member.

**It was moved by Vice President Corneille and seconded by Director Stewart to submit a vote for Kelly Gregg for LAFCO regular special district member. The motion carried 4-0 with all present voting in the affirmative. Director Longville was noted absent from the vote.**

**President McDonald: Yes  
Vice President Corneille: Yes  
Director Longville: Absent  
Director Raley: Yes  
Director Stewart: Yes**

President McDonald spoke in support of Director David E. Raley indicating that it would be a great benefit to the District if Director Raley was appointed.

**It was moved by Vice President Corneille and seconded by President McDonald to submit vote for Director David E. Raley for LAFCO alternate special district member. The motion carried 4-0 with all present voting in the affirmative. Director Longville was noted absent from the vote.**

**President McDonald: Yes  
Vice President Corneille: Yes  
Director Longville: Absent  
Director Raley: Yes  
Director Stewart: Yes**

I. CSDA CALL FOR NOMINATIONS FOR SEAT B, SOUTHERN NETWORK

Mr. Cozad said that this item is for any Board member interested in filling the position. The deadline for submittal is March 31. There were no nominations.

8. INFORMATION ITEMS

A. WASH PLAN IMPLEMENTATION

Ms. Miller provided a verbal update. She said the first Certificate of Inclusion (COI) was submitted by Valley Municipal for the Enhanced Recharge project. District staff has completed its review and it has been deemed to be in compliance with requirements. The COI will be submitted to USFWS for review. Ms. Miller said that Valley Municipal did an excellent job of preparing the COI application in compliance with the Wash Plan requirements. Staff is keeping a close eye on rainfall for spineflower and SBKR to

determine when surveys for those species should begin. We do not want to move forward with those projects unless we have appropriate rainfall to ensure the data we collect can be utilized over the long term. The spring 2022 gnatcatcher surveys are being scheduled. The District received the deemed complete 1600 permit for construction projects on Friday. The agencies have 90 days to issue a draft permit, although they may also request additional information. We have shared concerns with CDFW regarding the application of the regulations to our projects, and are working with their team to develop a reasonable path forward. The District has not received responses from the Regional Board or COE and is discussing next steps with our consultants. Mr. Cosgrove still waiting on the appraisal and reviewing the land exchange title report and exceptions to the title. This item was received and filed.

#### B. WASH PLAN TRAILS STATUS REPORT

Mr. Cozad introduced this item for discussion, noting its inclusion on page 160. He said that there is a draft MOU with the City of Redlands. In addition, at the request of Redlands, we are preparing a five-party agreement to cover details of implementation between the cities of Highland and Redlands, CEMEX, Robertson's, and the Conservation District. The goal is to open trails during the next fiscal year. This item was received and filed.

#### C. MENTONE SHOP IMPROVEMENT STATUS REPORT

The written report for this item is included on package page 162. Mr. Fogerson said that staff is moving forward with the contract with the low bidder; a draft Board item will come to the Board next month and will be reviewed by the Operations Committee. President McDonald requested that she be notified of the next Operations Committee. The list of anticipated costs is listed on package page 165. The total projects costs are estimated to be \$400,500. This item was received and filed.

#### D. GENERAL MANAGER'S REPORT AND MONTHLY RECHARGE REPORT

Mr. Cozad indicated that the written General Manager's Report was included in the Board package on pages 167 through 169. He thanked all those involved in the ARTP tour held on March 3. He indicated that there was great staff and Board member interaction. Mr. Cozad noted that there are woolly star growing in Plunge Creek from the seeding that was done last year as shown in a picture at the bottom of package page 169. The Monthly Recharge Report was included on package page 170. Mr. Cozad noted that there was an ACWA Award for Excellence project submitted by Valley Municipal, included on package page 171. Mr. Cozad said that the 90<sup>th</sup> celebration and retirement party for Mr. Cozad has been moved to May 11. EVWD is hosting a VIP Sterling Resource Center gathering on May 12. This item was received and filed.

#### E. FUTURE AGENDA ITEMS AND STAFF TASKS

Director Raley requested a Board workshop before Mr. Cozad retires on strategic planning. Vice President Corneille wants a formal review of the Community Strategic Plan and update. Director Stewart asked for updated maps for the ARTP for the Board room.

### 9. MONTHLY BOARD MEMBER MEETING REPORTS AND/OR BOARD MEMBER COMMENTS

Director Stewart attended the Bear Valley Mutual Water Company meeting and Bear Valley Mutual Lake Company Board of Directors meeting on February 15. He attended the Valley Municipal Board meeting on February 15 and the Valley Municipal Policy Workshop.

Vice President Corneille attended the Celebration of Life for Gabe Dela Rosa, former president of the Mentone Area Chamber of Commerce (MACA) on February 12, CSDA Governance Training on February 16 and 17, and Water Forum on February 17. He attended the MACA meeting on February 22 and Association of San Bernardino County Special Districts (ASBCSD) dinner on February 28. He attended the ARTP Tour on March 3.

Director Raley attended the CSDA Governance Training on February 16 and 17, Water Forum on February 17 and ASBCSD Dinner on February 28. He attended the Valley Municipal Board meeting on March 1, and Valley Municipal Resources Workshop on March 3.

President McDonald attended the Valley Municipal Engineering Workshop on March 8, Valley Municipal Resources Workshop on March 3 and Valley Municipal Board meeting on March 1. She attended the Valley Municipal Weaver Basin Groundbreaking on February 24, ASBCSD Board meeting on February 21 and ACWA State Legislative Committee on February 18. She attended CSDA Governance Training on February 16-17, the Valley Municipal Board meeting on February 15 and the Valley Municipal Policy Workshop on February 10.

Vice President Corneille's travel request was reviewed for his attendance at the ACWA Spring Conference in Sacramento in May.

**It was moved by President McDonald and seconded by Director Stewart to approve Vice President Corneille's ACWA Spring Conference Travel Request for the amount of \$3,171.86. The motion carried 4-0, with all Directors present voting in the affirmative. Director Longville was noted absent from the vote.**

**President McDonald: Yes  
Vice President Corneille: Yes  
Director Longville: Absent  
Director Raley: Yes  
Director Stewart: Yes**

10. UPCOMING MEETINGS

There were none discussed.

11. CLOSED SESSION

**It was moved by Vice President Corneille and seconded by Director Stewart to adjourn to Closed Session. The motion carried 4-0, with all Directors present voting in the affirmative. Director Longville was noted absent from the vote.**

**President McDonald: Yes  
Vice President Corneille: Yes  
Director Longville: Absent  
Director Raley: Yes  
Director Stewart: Yes**

General Counsel announced that the meeting would adjourn to a closed session to discuss all posted agenda items.

At 4:56 p.m. the meeting reconvened into open session. Mr. Cosgrove noted that there was no reportable action during closed session.

12. ADJOURN MEETING

**It was moved by Director Stewart and seconded by Director Raley to adjourn. The motion carried 4-0, with all Directors present voting in the affirmative. Director Longville was noted absent from the vote.**

**President McDonald: Yes  
Vice President Corneille: Yes  
Director Longville: Absent  
Director Raley: Yes  
Director Stewart: Yes**

At 4:57 p.m. the meeting adjourned to the Board meeting scheduled for 1:30 p.m. on April 13, 2022, in-person, teleconference, and Zoom meeting.

---

Daniel B. Cozad  
General Manager

## San Bernardino Valley Water Conservation District Expenditure Report March 2022

Num	Date	Name	Account	Class	Original Amount
<b>Online Pymt</b>	<b>03/08/2022</b>	<b>WEX Bank-Valero</b>	<b>1012 · Citizens Busine...</b>		<b>-1,101.00</b>
	02/23/2022		5320 · Fuel	1-Groundwater Ent.	1,101.00
TOTAL					1,101.00
<b>PC 03.09.22</b>	<b>03/09/2022</b>	<b>Paychex</b>	<b>1012 · Citizens Busine...</b>		<b>-123.66</b>
			6042 · Payroll Processing	4-General Fund Ent.	123.66
TOTAL					123.66
<b>23354</b>	<b>03/01/2022</b>	<b>Aaron Pederson</b>	<b>1012 · Citizens Busine...</b>		<b>-35.00</b>
	02/25/2022		6018 · Janitorial Services	4-General Fund Ent.	35.00
TOTAL					35.00
<b>23355</b>	<b>03/01/2022</b>	<b>ACWA/JPIA-Health</b>	<b>1012 · Citizens Busine...</b>		<b>-25,563.38</b>
	02/28/2022		6110 · Vision Insurance	4-General Fund Ent.	36.92
			6110 · Vision Insurance	1-Groundwater Ent.	127.76
			6110 · Vision Insurance	2-Redlands Plaza/...	11.36
			6110 · Vision Insurance	3-Land Resources	28.39
			6110 · Vision Insurance	5-Wash Plan	19.87
			6110 · Vision Insurance	6-Active Recharge ...	59.62
			6130 · Dental Insurance	4-General Fund Ent.	154.38
			6130 · Dental Insurance	1-Groundwater Ent.	534.40
			6130 · Dental Insurance	2-Redlands Plaza/...	47.50
			6130 · Dental Insurance	3-Land Resources	118.76
			6130 · Dental Insurance	5-Wash Plan	83.13
			6130 · Dental Insurance	6-Active Recharge ...	249.39
			6150 · Medical Insurance	4-General Fund Ent.	3,131.94
			6150 · Medical Insurance	1-Groundwater Ent.	10,841.36
			6150 · Medical Insurance	2-Redlands Plaza/...	963.68
			6150 · Medical Insurance	3-Land Resources	2,409.19
			6150 · Medical Insurance	5-Wash Plan	1,686.43
			6150 · Medical Insurance	6-Active Recharge ...	5,059.30
TOTAL					25,563.38
<b>23356</b>	<b>03/01/2022</b>	<b>Brownstein Hyatt Farb...</b>	<b>1012 · Citizens Busine...</b>		<b>-15,375.00</b>
	02/16/2022		5122 · Wash Plan Profe...	5-Wash Plan	15,375.00
TOTAL					15,375.00
<b>23357</b>	<b>03/01/2022</b>	<b>Citizens Business Bank</b>	<b>1012 · Citizens Busine...</b>		<b>-2,980.98</b>
	02/10/2022		5210 · Equipment Maint...	1-Groundwater Ent.	227.84
			5215 · Property Mainte...	1-Groundwater Ent.	44.85
			5215 · Property Mainte...	3-Land Resources	11.21
			6001 · General Adminis...	4-General Fund Ent.	129.87
			6001 · General Adminis...	1-Groundwater Ent.	129.86
			6002 · Website Adminis...	4-General Fund Ent.	365.00
			6016 · Redlands Plaza ...	2-Redlands Plaza/...	696.00
			6030 · Office Supplies	4-General Fund Ent.	403.82
			6030 · Office Supplies	1-Groundwater Ent.	25.24
			6030 · Office Supplies	2-Redlands Plaza/...	50.48
			6030 · Office Supplies	3-Land Resources	25.24
			6039 · Postage and Ov...	4-General Fund Ent.	55.00
			6039 · Postage and Ov...	1-Groundwater Ent.	25.00
			6039 · Postage and Ov...	2-Redlands Plaza/...	10.00
			6039 · Postage and Ov...	3-Land Resources	10.00

## San Bernardino Valley Water Conservation District Expenditure Report March 2022

Num	Date	Name	Account	Class	Original Amount
			6051 · Uniforms	4-General Fund Ent.	48.33
			6051 · Uniforms	1-Groundwater Ent.	112.78
			6060 · Outreach	4-General Fund Ent.	4.56
			6060 · Outreach	1-Groundwater Ent.	2.87
			6060 · Outreach	3-Land Resources	4.77
			6060 · Outreach	6-Active Recharge ...	2.15
			6090 · Subscriptions/Pu...	4-General Fund Ent.	596.11
TOTAL					2,980.98
<b>23358</b>	<b>03/01/2022</b>	<b>County of San Bernardi...</b>	<b>1012 · Citizens Busine...</b>		<b>-23,409.00</b>
	02/01/2022		5225 · Field Clean Up-II...	1-Groundwater Ent.	23,409.00
TOTAL					23,409.00
<b>23359</b>	<b>03/01/2022</b>	<b>CWE-CA Watershed En...</b>	<b>1012 · Citizens Busine...</b>		<b>-202.00</b>
	02/24/2022		1700 · WIP-Mill Creek ...	1-Groundwater Ent.	202.00
TOTAL					202.00
<b>23360</b>	<b>03/01/2022</b>	<b>Frontier-7275</b>	<b>1012 · Citizens Busine...</b>		<b>-117.80</b>
	02/19/2022		5440 · Telephone	4-General Fund Ent.	29.97
			5440 · Telephone	1-Groundwater Ent.	12.84
			5470 · Internet Services	4-General Fund Ent.	37.50
			5470 · Internet Services	1-Groundwater Ent.	22.50
			5470 · Internet Services	2-Redlands Plaza/...	3.75
			5470 · Internet Services	3-Land Resources	11.24
TOTAL					117.80
<b>23361</b>	<b>03/01/2022</b>	<b>JAN-PRO Cleaning Sys...</b>	<b>1012 · Citizens Busine...</b>		<b>-700.00</b>
	03/01/2022		6018 · Janitorial Services	4-General Fund Ent.	700.00
TOTAL					700.00
<b>23362</b>	<b>03/01/2022</b>	<b>Netsteller</b>	<b>1012 · Citizens Busine...</b>		<b>-4,841.22</b>
	02/17/2022		7210 · Computer Hardw...	4-General Fund Ent.	3,630.92
			7210 · Computer Hardw...	1-Groundwater Ent.	1,210.30
TOTAL					4,841.22
<b>23363</b>	<b>03/01/2022</b>	<b>Patton Sales Corp</b>	<b>1012 · Citizens Busine...</b>		<b>-35.29</b>
	02/16/2022		5215 · Property Mainte...	1-Groundwater Ent.	28.23
			5215 · Property Mainte...	3-Land Resources	7.06
TOTAL					35.29
<b>23364</b>	<b>03/01/2022</b>	<b>Quill Corporation</b>	<b>1012 · Citizens Busine...</b>		<b>-135.89</b>
	02/10/2022		6030 · Office Supplies	4-General Fund Ent.	108.71
			6030 · Office Supplies	1-Groundwater Ent.	6.79
			6030 · Office Supplies	2-Redlands Plaza/...	13.60
			6030 · Office Supplies	3-Land Resources	6.79
TOTAL					135.89

**San Bernardino Valley Water Conservation District**  
**Expenditure Report**  
**March 2022**

<u>Num</u>	<u>Date</u>	<u>Name</u>	<u>Account</u>	<u>Class</u>	<u>Original Amount</u>
<b>23365</b>	<b>03/01/2022</b>	<b>The Gas Company</b>	<b>1012 · Citizens Busine...</b>		<b>-258.17</b>
	02/16/2022		5450 · Natural Gas	4-General Fund Ent.	154.90
			5450 · Natural Gas	1-Groundwater Ent.	103.27
TOTAL					258.17
<b>23366</b>	<b>03/01/2022</b>	<b>Thomas Purvis</b>	<b>1012 · Citizens Busine...</b>		<b>-25.81</b>
	02/16/2022		5310 · Vehicle Mainten...	1-Groundwater Ent.	25.81
TOTAL					25.81
<b>23368</b>	<b>03/16/2022</b>	<b>American Power Security</b>	<b>1012 · Citizens Busine...</b>		<b>-970.00</b>
	03/01/2022		6026 · Redlands Plaza ...	2-Redlands Plaza/...	970.00
TOTAL					970.00
<b>23369</b>	<b>03/16/2022</b>	<b>Assoc. San Bernardino...</b>	<b>1012 · Citizens Busine...</b>		<b>-96.00</b>
	03/15/2022		6425 · Meals	4-General Fund Ent.	96.00
TOTAL					96.00
<b>23370</b>	<b>03/16/2022</b>	<b>Bri Communications</b>	<b>1012 · Citizens Busine...</b>		<b>-7,500.00</b>
	03/02/2022		6060 · Outreach	4-General Fund Ent.	2,250.00
			6060 · Outreach	1-Groundwater Ent.	1,500.00
			6060 · Outreach	3-Land Resources	2,493.75
			6060 · Outreach	5-Wash Plan	506.25
			6060 · Outreach	6-Active Recharge ...	750.00
TOTAL					7,500.00
<b>23371</b>	<b>03/16/2022</b>	<b>Brownstein Hyatt Farb...</b>	<b>1012 · Citizens Busine...</b>		<b>-15,375.00</b>
	03/10/2022		5120 · Misc. Profession...	3-Land Resources	15,375.00
TOTAL					15,375.00
<b>23372</b>	<b>03/16/2022</b>	<b>Castro Landscaping Se...</b>	<b>1012 · Citizens Busine...</b>		<b>-250.00</b>
	02/28/2022		6026 · Redlands Plaza ...	2-Redlands Plaza/...	250.00
TOTAL					250.00
<b>23373</b>	<b>03/16/2022</b>	<b>Corneille, Richard</b>	<b>1012 · Citizens Busine...</b>		<b>-36.27</b>
	03/02/2022		6410 · Mileage	4-General Fund Ent.	36.27
TOTAL					36.27
<b>23374</b>	<b>03/16/2022</b>	<b>Daily Journal Corporati...</b>	<b>1012 · Citizens Busine...</b>		<b>-495.00</b>
	02/28/2022		6091 · Public Notices	4-General Fund Ent.	99.00
			6091 · Public Notices	1-Groundwater Ent.	396.00
TOTAL					495.00

**San Bernardino Valley Water Conservation District**  
**Expenditure Report**  
**March 2022**

<u>Num</u>	<u>Date</u>	<u>Name</u>	<u>Account</u>	<u>Class</u>	<u>Original Amount</u>
<b>23375</b>	<b>03/16/2022</b>	<b>Day Lite Maintenance, I...</b>	<b>1012 · Citizens Busine...</b>		<b>-156.00</b>
	03/01/2022		6026 · Redlands Plaza ...	2-Redlands Plaza/...	156.00
TOTAL					156.00
<b>23376</b>	<b>03/16/2022</b>	<b>Diamond Environment...</b>	<b>1012 · Citizens Busine...</b>		<b>-88.78</b>
	02/28/2022		5460 · Water / Trash / ...	4-General Fund Ent.	44.39
			5460 · Water / Trash / ...	1-Groundwater Ent.	35.51
			5460 · Water / Trash / ...	3-Land Resources	8.88
TOTAL					88.78
<b>23377</b>	<b>03/16/2022</b>	<b>DUDEK</b>	<b>1012 · Citizens Busine...</b>		<b>-4,695.00</b>
	01/21/2022		5123 · Habitat Manage...	5-Wash Plan	1,120.00
	03/07/2022		5123 · Habitat Manage...	5-Wash Plan	1,050.00
	02/17/2022		5120 · Misc. Profession...	3-Land Resources	2,525.00
TOTAL					4,695.00
<b>23378</b>	<b>03/16/2022</b>	<b>Edison - 6256 (Redland...</b>	<b>1012 · Citizens Busine...</b>		<b>-187.17</b>
	03/02/2022		6026 · Redlands Plaza ...	2-Redlands Plaza/...	187.17
TOTAL					187.17
<b>23379</b>	<b>03/16/2022</b>	<b>Edison - 6493</b>	<b>1012 · Citizens Busine...</b>		<b>-61.52</b>
	03/11/2022		5420 · Electricity	4-General Fund Ent.	17.23
			5420 · Electricity	1-Groundwater Ent.	12.30
			5420 · Electricity	2-Redlands Plaza/...	31.99
TOTAL					61.52
<b>23380</b>	<b>03/16/2022</b>	<b>Edison - 8958</b>	<b>1012 · Citizens Busine...</b>		<b>-326.68</b>
	03/09/2022		5420 · Electricity	4-General Fund Ent.	91.47
			5420 · Electricity	1-Groundwater Ent.	65.34
			5420 · Electricity	2-Redlands Plaza/...	169.87
TOTAL					326.68
<b>23381</b>	<b>03/16/2022</b>	<b>Edison - 9779</b>	<b>1012 · Citizens Busine...</b>		<b>-251.65</b>
	03/02/2022		5420 · Electricity	4-General Fund Ent.	70.46
			5420 · Electricity	1-Groundwater Ent.	50.33
			5420 · Electricity	2-Redlands Plaza/...	130.86
TOTAL					251.65
<b>23382</b>	<b>03/16/2022</b>	<b>Empire Disposal</b>	<b>1012 · Citizens Busine...</b>		<b>-173.39</b>
	02/28/2022		5460 · Water / Trash / ...	4-General Fund Ent.	86.70
			5460 · Water / Trash / ...	1-Groundwater Ent.	69.35
			5460 · Water / Trash / ...	3-Land Resources	17.34
TOTAL					173.39

**San Bernardino Valley Water Conservation District**  
**Expenditure Report**  
**March 2022**

04/05/22

<u>Num</u>	<u>Date</u>	<u>Name</u>	<u>Account</u>	<u>Class</u>	<u>Original Amount</u>
<b>23383</b>	<b>03/16/2022</b>	<b>Employee Relations Ne...</b>	<b>1012 · Citizens Busine...</b>		<b>-110.60</b>
	02/28/2022		6001 · General Adminis...	4-General Fund Ent.	55.30
			6001 · General Adminis...	1-Groundwater Ent.	55.30
TOTAL					110.60
<b>23384</b>	<b>03/16/2022</b>	<b>Erwin Fogerson</b>	<b>1012 · Citizens Busine...</b>		<b>-110.69</b>
	03/10/2022		6510 · Mileage	4-General Fund Ent.	44.28
			6510 · Mileage	1-Groundwater Ent.	27.67
			6510 · Mileage	3-Land Resources	11.07
			6510 · Mileage	6-Active Recharge ...	27.67
TOTAL					110.69
<b>23385</b>	<b>03/16/2022</b>	<b>Frontier-4860</b>	<b>1012 · Citizens Busine...</b>		<b>-430.33</b>
	02/28/2022		5440 · Telephone	4-General Fund Ent.	234.75
			5440 · Telephone	1-Groundwater Ent.	100.60
			5470 · Internet Services	4-General Fund Ent.	47.49
			5470 · Internet Services	1-Groundwater Ent.	28.49
			5470 · Internet Services	2-Redlands Plaza/...	4.75
			5470 · Internet Services	3-Land Resources	14.25
TOTAL					430.33
<b>23386</b>	<b>03/16/2022</b>	<b>Highland Community N...</b>	<b>1012 · Citizens Busine...</b>		<b>-600.00</b>
	02/28/2022		6091 · Public Notices	4-General Fund Ent.	120.00
			6091 · Public Notices	1-Groundwater Ent.	480.00
TOTAL					600.00
<b>23387</b>	<b>03/16/2022</b>	<b>Home Depot Credit Ser...</b>	<b>1012 · Citizens Busine...</b>		<b>-247.98</b>
	02/28/2022		5210 · Equipment Maint...	1-Groundwater Ent.	117.46
			5215 · Property Mainte...	1-Groundwater Ent.	92.28
			5215 · Property Mainte...	3-Land Resources	23.07
			5310 · Vehicle Mainten...	1-Groundwater Ent.	15.17
TOTAL					247.98
<b>23388</b>	<b>03/16/2022</b>	<b>Katelyn Scholte</b>	<b>1012 · Citizens Busine...</b>		<b>-76.38</b>
	03/10/2022		6510 · Mileage	4-General Fund Ent.	30.55
			6510 · Mileage	1-Groundwater Ent.	19.10
			6510 · Mileage	3-Land Resources	7.64
			6510 · Mileage	6-Active Recharge ...	19.09
TOTAL					76.38
<b>23389</b>	<b>03/16/2022</b>	<b>Lowe's Companies, Inc.</b>	<b>1012 · Citizens Busine...</b>		<b>-239.85</b>
	02/25/2022		5210 · Equipment Maint...	1-Groundwater Ent.	57.26
			5215 · Property Mainte...	1-Groundwater Ent.	22.92
			5215 · Property Mainte...	3-Land Resources	5.73
			5460 · Water / Trash / ...	4-General Fund Ent.	76.97
			5460 · Water / Trash / ...	1-Groundwater Ent.	61.58
			5460 · Water / Trash / ...	3-Land Resources	15.39
TOTAL					239.85

## San Bernardino Valley Water Conservation District Expenditure Report March 2022

Num	Date	Name	Account	Class	Original Amount
<b>23390</b>	<b>03/16/2022</b>	<b>Nationwide Legal, LLC</b>	<b>1012 · Citizens Busine...</b>		<b>-333.45</b>
	02/28/2022		5120 · Misc. Profession...	2-Redlands Plaza/...	333.45
TOTAL					333.45
<b>23391</b>	<b>03/16/2022</b>	<b>Netsteller</b>	<b>1012 · Citizens Busine...</b>		<b>-1,828.25</b>
	02/01/2022		5160 · IT Support	4-General Fund Ent.	180.00
			5160 · IT Support	1-Groundwater Ent.	225.00
			5160 · IT Support	3-Land Resources	45.00
	03/01/2022		5160 · IT Support	4-General Fund Ent.	344.24
			5160 · IT Support	1-Groundwater Ent.	516.38
			5160 · IT Support	3-Land Resources	286.88
	03/01/2022		6027 · Computer Softw...	4-General Fund Ent.	173.05
			6027 · Computer Softw...	2-Redlands Plaza/...	11.54
			6027 · Computer Softw...	3-Land Resources	23.08
			6027 · Computer Softw...	1-Groundwater Ent.	23.08
TOTAL					1,828.25
<b>23392</b>	<b>03/16/2022</b>	<b>O'Reilly</b>	<b>1012 · Citizens Busine...</b>		<b>-14.13</b>
	03/01/2022		5210 · Equipment Maint...	1-Groundwater Ent.	14.13
TOTAL					14.13
<b>23393</b>	<b>03/16/2022</b>	<b>ReadyRefresh by Nestle</b>	<b>1012 · Citizens Busine...</b>		<b>-15.93</b>
	02/24/2022		5460 · Water / Trash / ...	4-General Fund Ent.	4.46
			5460 · Water / Trash / ...	1-Groundwater Ent.	3.19
			5460 · Water / Trash / ...	3-Land Resources	8.28
TOTAL					15.93
<b>23394</b>	<b>03/16/2022</b>	<b>Redlands Chamber of ...</b>	<b>1012 · Citizens Busine...</b>		<b>-150.00</b>
	03/03/2022		6093 · Memberships	4-General Fund Ent.	150.00
TOTAL					150.00
<b>23395</b>	<b>03/16/2022</b>	<b>San Bernardino Area C...</b>	<b>1012 · Citizens Busine...</b>		<b>-250.00</b>
	03/08/2022		6093 · Memberships	4-General Fund Ent.	250.00
TOTAL					250.00
<b>23396</b>	<b>03/16/2022</b>	<b>Terminix</b>	<b>1012 · Citizens Busine...</b>		<b>-86.00</b>
	02/08/2022		6026 · Redlands Plaza ...	2-Redlands Plaza/...	86.00
TOTAL					86.00
<b>23397</b>	<b>03/16/2022</b>	<b>WEX Bank-Shell</b>	<b>1012 · Citizens Busine...</b>		<b>-523.00</b>
	03/06/2022		5320 · Fuel	1-Groundwater Ent.	523.00
TOTAL					523.00

## San Bernardino Valley Water Conservation District Expenditure Report March 2022

Num	Date	Name	Account	Class	Original Amount
<b>23398</b>	<b>03/16/2022</b>	<b>Xerox Financial Services</b>	<b>1012 · Citizens Busine...</b>		<b>-337.44</b>
	03/02/2022		6033 · Office Equipmen...	4-General Fund Ent.	253.08
			6033 · Office Equipmen...	1-Groundwater Ent.	16.87
			6033 · Office Equipmen...	2-Redlands Plaza/...	50.62
			6033 · Office Equipmen...	3-Land Resources	16.87
TOTAL					337.44
<b>23399</b>	<b>03/17/2022</b>	<b>Wendy Gladeny dba Pe...</b>	<b>1012 · Citizens Busine...</b>		<b>-3,975.00</b>
	03/17/2022		5120 · Misc. Profession...	4-General Fund Ent.	1,311.75
			5120 · Misc. Profession...	1-Groundwater Ent.	1,311.75
			5120 · Misc. Profession...	3-Land Resources	1,351.50
TOTAL					3,975.00
<b>23400</b>	<b>03/30/2022</b>	<b>AAA Alarm Systems, Inc.</b>	<b>1012 · Citizens Busine...</b>		<b>-129.00</b>
	04/01/2022		5410 · Alarm Service	4-General Fund Ent.	64.50
			5410 · Alarm Service	1-Groundwater Ent.	64.50
TOTAL					129.00
<b>23401</b>	<b>03/30/2022</b>	<b>Aaron Pederson</b>	<b>1012 · Citizens Busine...</b>		<b>-35.00</b>
	03/25/2022		6018 · Janitorial Services	4-General Fund Ent.	35.00
TOTAL					35.00
<b>23402</b>	<b>03/30/2022</b>	<b>AECOM Technical Serv...</b>	<b>1012 · Citizens Busine...</b>		<b>-28,884.25</b>
	03/16/2022		1702 · WIP-Mill Creek ...	1-Groundwater Ent.	11,205.50
	03/24/2022		5122 · Wash Plan Profe...	5-Wash Plan	17,678.75
TOTAL					28,884.25
<b>23403</b>	<b>03/30/2022</b>	<b>Citizens Business Bank</b>	<b>1012 · Citizens Busine...</b>		<b>-6,166.19</b>
	03/14/2022		5210 · Equipment Maint...	1-Groundwater Ent.	161.59
			5215 · Property Mainte...	1-Groundwater Ent.	208.75
			5215 · Property Mainte...	3-Land Resources	52.19
			6001 · General Adminis...	4-General Fund Ent.	7.06
			6001 · General Adminis...	1-Groundwater Ent.	7.06
			6002 · Website Adminis...	4-General Fund Ent.	478.97
			6027 · Computer Softw...	4-General Fund Ent.	209.98
			6027 · Computer Softw...	1-Groundwater Ent.	14.00
			6027 · Computer Softw...	2-Redlands Plaza/...	28.00
			6027 · Computer Softw...	3-Land Resources	28.00
			6030 · Office Supplies	4-General Fund Ent.	1,485.84
			6030 · Office Supplies	1-Groundwater Ent.	92.87
			6030 · Office Supplies	2-Redlands Plaza/...	185.73
			6030 · Office Supplies	3-Land Resources	92.87
			6036 · Printing	4-General Fund Ent.	135.94
			6036 · Printing	1-Groundwater Ent.	108.75
			6036 · Printing	3-Land Resources	27.19
			6039 · Postage and Ov...	4-General Fund Ent.	66.20
			6039 · Postage and Ov...	1-Groundwater Ent.	30.09
			6039 · Postage and Ov...	2-Redlands Plaza/...	12.04
			6039 · Postage and Ov...	3-Land Resources	12.04
			6515 · Air Fare	4-General Fund Ent.	65.38
			6515 · Air Fare	1-Groundwater Ent.	21.80
			6515 · Air Fare	3-Land Resources	52.31
			6515 · Air Fare	6-Active Recharge ...	78.47

## San Bernardino Valley Water Conservation District Expenditure Report March 2022

Num	Date	Name	Account	Class	Original Amount
			6525 · Meals	4-General Fund Ent.	35.80
			6525 · Meals	1-Groundwater Ent.	27.85
			6525 · Meals	3-Land Resources	15.91
			7240 · Office Equipment	4-General Fund Ent.	2,423.51
TOTAL					6,166.19
<b>23404</b>	<b>03/30/2022</b>	<b>Cota's Tree Service, Inc.</b>	<b>1012 · Citizens Busine...</b>		<b>-1,500.00</b>
	03/24/2022		6016 · Redlands Plaza ...	2-Redlands Plaza/...	1,500.00
TOTAL					1,500.00
<b>23405</b>	<b>03/30/2022</b>	<b>CWE-CA Watershed En...</b>	<b>1012 · Citizens Busine...</b>		<b>-501.00</b>
	03/22/2022		1700 · WIP-Mill Creek ...	1-Groundwater Ent.	501.00
TOTAL					501.00
<b>23406</b>	<b>03/30/2022</b>	<b>FMB Truck Outfitters</b>	<b>1012 · Citizens Busine...</b>		<b>-1,801.45</b>
	03/21/2022		5210 · Equipment Maint...	1-Groundwater Ent.	170.08
	03/23/2022		7230 · Field Equipment ...	1-Groundwater Ent.	1,631.37
TOTAL					1,801.45
<b>23407</b>	<b>03/30/2022</b>	<b>Frontier-7275</b>	<b>1012 · Citizens Busine...</b>		<b>-117.80</b>
	03/19/2022		5440 · Telephone	4-General Fund Ent.	29.97
			5440 · Telephone	1-Groundwater Ent.	12.84
			5470 · Internet Services	4-General Fund Ent.	37.50
			5470 · Internet Services	1-Groundwater Ent.	22.50
			5470 · Internet Services	2-Redlands Plaza/...	3.75
			5470 · Internet Services	3-Land Resources	11.24
TOTAL					117.80
<b>23408</b>	<b>03/30/2022</b>	<b>Highland Area Chambe...</b>	<b>1012 · Citizens Busine...</b>		<b>-600.00</b>
	03/15/2022		6093 · Memberships	4-General Fund Ent.	600.00
TOTAL					600.00
<b>23409</b>	<b>03/30/2022</b>	<b>IERCD</b>	<b>1012 · Citizens Busine...</b>		<b>-3,300.00</b>
	03/23/2022		6060 · Outreach	4-General Fund Ent.	990.00
			6060 · Outreach	1-Groundwater Ent.	660.00
			6060 · Outreach	3-Land Resources	1,097.25
			6060 · Outreach	5-Wash Plan	222.75
			6060 · Outreach	6-Active Recharge ...	330.00
TOTAL					3,300.00
<b>23410</b>	<b>03/30/2022</b>	<b>JAN-PRO Cleaning Sys...</b>	<b>1012 · Citizens Busine...</b>		<b>-700.00</b>
	04/01/2022		6018 · Janitorial Services	4-General Fund Ent.	700.00
TOTAL					700.00

## San Bernardino Valley Water Conservation District Expenditure Report March 2022

Num	Date	Name	Account	Class	Original Amount
<b>23411</b>	<b>03/30/2022</b>	<b>O'Reilly</b>	<b>1012 · Citizens Busine...</b>		<b>-14.44</b>
	03/07/2022		5310 · Vehicle Mainten...	1-Groundwater Ent.	14.44
TOTAL					14.44
<b>23412</b>	<b>03/30/2022</b>	<b>Panoramic</b>	<b>1012 · Citizens Busine...</b>		<b>-1,285.00</b>
	03/22/2022		6060 · Outreach	4-General Fund Ent.	385.50
			6060 · Outreach	1-Groundwater Ent.	257.00
			6060 · Outreach	3-Land Resources	427.26
			6060 · Outreach	5-Wash Plan	86.74
			6060 · Outreach	6-Active Recharge ...	128.50
TOTAL					1,285.00
<b>23413</b>	<b>03/30/2022</b>	<b>Quill Corporation</b>	<b>1012 · Citizens Busine...</b>		<b>-115.59</b>
	03/15/2022		6030 · Office Supplies	4-General Fund Ent.	92.47
			6030 · Office Supplies	1-Groundwater Ent.	5.78
			6030 · Office Supplies	2-Redlands Plaza/...	11.56
			6030 · Office Supplies	3-Land Resources	5.78
TOTAL					115.59
<b>23414</b>	<b>03/30/2022</b>	<b>Redlands Ford-Ken Gr...</b>	<b>1012 · Citizens Busine...</b>		<b>-68.27</b>
	02/25/2022		5310 · Vehicle Mainten...	1-Groundwater Ent.	68.27
TOTAL					68.27
<b>23415</b>	<b>03/30/2022</b>	<b>Richard Freund</b>	<b>1012 · Citizens Busine...</b>		<b>-75.00</b>
	03/25/2022		6001 · General Adminis...	4-General Fund Ent.	75.00
TOTAL					75.00
<b>23416</b>	<b>03/30/2022</b>	<b>Stewart Handling</b>	<b>1012 · Citizens Busine...</b>		<b>-13,568.15</b>
	03/22/2022		7140 · Mentone Propert...	1-Groundwater Ent.	13,568.15
TOTAL					13,568.15
<b>23417</b>	<b>03/30/2022</b>	<b>The Gas Company</b>	<b>1012 · Citizens Busine...</b>		<b>-196.01</b>
	03/16/2022		5450 · Natural Gas	4-General Fund Ent.	117.61
			5450 · Natural Gas	1-Groundwater Ent.	78.40
TOTAL					196.01
<b>23418</b>	<b>03/30/2022</b>	<b>Water Systems Consult...</b>	<b>1012 · Citizens Busine...</b>		<b>-1,167.50</b>
	02/28/2022		5120 · Misc. Profession...	1-Groundwater Ent.	1,167.50
TOTAL					1,167.50
<b>23419</b>	<b>03/30/2022</b>	<b>WEX Bank-Valero</b>	<b>1012 · Citizens Busine...</b>		<b>-947.21</b>
	03/23/2022		5320 · Fuel	1-Groundwater Ent.	947.21
TOTAL					947.21

**San Bernardino Valley Water Conservation District**  
**Expenditure Report**  
March 2022

---

<u>Num</u>	<u>Date</u>	<u>Name</u>	<u>Account</u>	<u>Class</u>	<u>Original Amount</u>
23420	03/31/2022	Citrograph Printing Co.	1012 · Citizens Busine...		<b>-688.39</b>
			6036 · Printing	4-General Fund Ent.	344.20
			6036 · Printing	1-Groundwater Ent.	273.36
			6036 · Printing	3-Land Resources	70.83
TOTAL					<u>688.39</u>

San Bernardino Valley Water Conservation District  
**Director Fees Expenditure Payroll Report**  
March 2022

---

Pay Date	Name	For Period	Director Fees	Taxes Withheld	Check Amt
3/9/2022	McDonald, M	Feb-22	\$ 1,722.00	\$ 157.29	\$ 1,564.71
3/9/2022	Corneille, D	Feb-22	\$ 1,968.00	\$ 309.21	\$ 1,658.79
3/23/2022	McDonald, M	Mar-22	\$ 1,722.00	\$ 157.29	\$ 1,564.71



**San Bernardino Valley  
Water Conservation District**

Helping Nature Store Our Water

Memorandum No. 1856

**To: Board of Directors**

**From: Finance & Administration Committee  
Betsy Miller, Assistant General Manager**

**Date: April 13, 2022**

**Subject: 3<sup>rd</sup> Quarter Unaudited Financials for 2021-2022**

---

**RECOMMENDATION**

The Finance & Administration Committee recommends the Board approve the third quarter 2021-2022 financial reports as presented.

**BACKGROUND**

The Finance & Administration Committee met on March 23, 2022, to review the third quarter unaudited financial reports. No changes were recommended.

**DISCUSSION**

Revenue and expenses are generally in agreement with projections. Interest rates and associated yields on investments continue to be low but are expected to increase in the next fiscal year. GL 4025 Wash Plan revenue is primarily income extended from reserves: Staff are reviewing these items and will allocate charges to the appropriate categories prior to year-end. These allocations will also be included in the draft FY23 budget presented to at the up-coming budget workshop. The third quarter financial statement will be used as a basis/check during FY23 budget preparation.

**FISCAL IMPACT**

There is no fiscal impact from reporting the financial status of the District.

**POTENTIAL MOTIONS**

1. Accept the Finance & Administration Committee's recommendation to approve the third quarter financial report for FY 2021-2022 as presented.
2. Request this item be tabled and referred to Finance & Administration Committee for reconsideration of specific issues discussed.

**ATTACHMENTS OR MATERIALS**

2021-2022 Third Quarter Summary Budget Worksheet  
SBVWCD Quarterly Investment Report

GL ACCT:	GL DESCRIPTION:	Approved 2021-2022 Budget	Expended/ Received to Date as of 03/16/22	Actual Over/Under Budget	Projected Annual Costs (7/1/21-6/30/22)	GENERAL FUND			GROUNDWATER RECHARGE ENTERPRISE			REDLANDS PLAZA & LEASED PROPERTY- MENTONE HOUSE			LAND RESOURCE			ACTIVE RECHARGE TRANSFER PROJECTS			WASH PLAN and TRUST SUPPORT		
						2021 BUDGET:	% BUDGET	BASIS:	2021 BUDGET:	% BUDGET	BASIS:	2021 BUDGET:	% BUDGET	BASIS:	2021 BUDGET:	% BUDGET	BASIS:	2021 Budget	% BUDGET	BASIS:	2021 Budget	% BUDGET	BASIS:
<b>Approved 2021-2022 Budget</b>																							
<b>INCOME:</b>																							
4012-15	INTEREST INCOME	273,460.00	-15,129.28	-288,589.28	46,500.00	111,460.00			0.00			0.00			0.00			162,000.00			0.00		
4017	ARTP CAPITAL INCOME	615,000.00	0.00	-615,000.00	300,000.00	61,500.00	10.00%		0.00	0.00%		0.00	0.00%		0.00	0.00%		553,500.00	90%		0.00		
4021-24	GROUNDWATER	1,263,295.07	1,314,985.32	51,690.25	1,320,227.58	0.00			1,263,295.07			0.00			0.00			0.00			0.00		
4022	GROUNDWATER CHARGE	549,681.07	604,738.81	55,057.74	609,681.07	0.00			549,681.07	100.00%	PROPOSED	0.00			0.00			0.00			0.00		
4024	GROUNDWATER COUNCIL REVENUE	696,800.00	696,802.00	2.00	696,802.00	0.00	5% increase		696,800.00	100.00%	PROPOSED	0.00			0.00			0.00			0.00		
4026	GW SUSTAINABILITY/REPLENISHMENT	16,814.00	13,444.51	-3,369.49	13,744.51	0.00			16,814.00	100.00%	PROPOSED	0.00			0.00			0.00			0.00		
4031-34	MINING	648,000.00	614,501.22	-33,498.78	844,501.22	0.00			0.00			0.00			648,000.00			0.00			0.00		
4036,40,80	MISCELLANEOUS	70,000.00	68,239.35	-1,760.65	85,986.69	7,500.00			30,000.00			0.00			62,500.00			0.00			0.00		
4036	AGGREGATE MAINTENANCE	60,000.00	56,986.69	-3,013.31	68,986.69	0.00			0.00			0.00			60,000.00	100.00%	EST FROM 2010	0.00			0.00		
4050	PROPERTY TAX	130,817.65	113,142.33	-17,675.32	130,817.65	130,817.65	100.00%	+5%	0.00			0.00			0.00			0.00			0.00		
4055	SBVMWD LEASE AGREEMENT	421,846.12	431,810.98	9,964.86	431,810.98	189,830.75	45.00%	+1.6% CPI	232,015.36	55.00%		0.00			0.00		Land Lease Cost	0.00			0.00		
4062-66	RENTALS	263,042.69	159,470.91	-103,571.78	203,776.59	0.00			0.00			263,042.69			0.00			0.00			0.00		
4080	EXCHANGE PLAN	30,000.00	30,000.00	0.00	30,000.00	0.00			30,000.00	100.00%	HISTORIC	0.00			0.00			0.00			0.00		
4025	WASH PLAN REVENUE * from Reserves	220,000.00	960,943.89	740,943.89	1,020,943.89	0.00		State and Waters done	0.00			0.00			0.00			0.00			220,000.00	100.00%	Inc. State Permittin
	<b>TOTAL INCOME:</b>	<b>4,527,961.52</b>	<b>3,677,964.72</b>	<b>-849,996.80</b>	<b>4,614,564.60</b>	<b>501,108.40</b>			<b>1,525,310.43</b>			<b>263,042.69</b>			<b>710,500.00</b>			<b>715,500.00</b>			<b>812,500.00</b>		
<b>EXPENSES:</b>																							
5000	MISCELLANEOUS	302,418.94	63,653.19	-238,765.75	152,418.94	32,418.94			75,000.00			0.00			60,000.00			135,000.00			0.00		
5100	PROFESSIONAL SERVICES	810,664.00	171,947.17	-638,716.83	444,514.00	46,870.00			141,009.00			4,035.00			104,411.00			145,850.00			351,675.00		
5120	MISC. PROFESSIONAL SERVICES	300,000.00	61,234.25	-238,765.75	150,000.00	30,000.00	10.00%	Includes GSC Support	75,000.00	25.00%	GSC and Bio Support	0.00	0.00%		60,000.00	20.00%		135,000.00	45%		0.00		
5122	WASH PLAN PROFESSIONAL SERVICES	245,000.00	420,587.15	175,587.15	445,000.00	0.00		Per Wash Plan Budget	0.00			0.00			0.00			0.00			245,000.00	100.00%	Per WP Budget
52-53	FIELD OPERATIONS	190,325.00	70,025.09	-120,299.91	190,325.00	0.00			158,325.00			0.00			32,000.00			0.00			0.00		
5400	UTILITIES	27,993.62	20,701.83	-7,291.79	29,884.48	12,037.27			10,843.87			4,070.48			1,042.01			0.00			0.00		
6000	GENERAL ADMINISTRATION	331,002.73	330,490.34	-512.39	467,425.00	115,987.79			59,853.15			85,061.79			52,550.00			16,500.00			4,050.00		
6100	BENEFITS	592,263.29	347,020.47	-245,242.82	592,263.29	76,994.23			332,722.34			29,575.32			73,938.30			155,270.42			51,756.81		
6160	PAYROLL TAXES - EMPLOYER	102,949.70	66,618.34	-36,331.36	102,949.70	13,383.46	13%	Consolidated costs 2014	56,519.39	45%	Based on percent of hours	5,023.95	4%		12,559.86	10%		26,375.71	21%		8,791.90	7%	
6170	PERS RETIREMENT	296,477.60	254,894.60	-41,583.00	296,477.60	38,542.09	13%	Noticed Increase	162,766.20	45%	Based on percent of hours	14,468.11	4%		36,170.27	10%		75,957.56	21%		25,319.19	7%	
6170.01	PERS EMPLOYEE CONTRIBUTION	-45,326.73	-146,039.19	-100,712.46	-176,039.19	-5,892.47	13%	Overhead Offset 22%	-20,397.03	45%		-1,813.07	4%		-4,532.67	10%		-9,518.61	21%		-3,172.87	7%	
6200	SALARIES	1,422,210.29	1,068,468.76	-353,741.53	1,422,210.29	192,617.90			664,482.46			65,078.74			194,793.97			404,556.85			171,190.70		
6300	INSURANCE	38,071.87	48,992.15	10,920.28	40,537.74	1,903.59			28,553.90			5,710.78			1,903.59			0.00			0.00		
6400	DIRECTOR EXPENSES	132,401.20	60,552.05	-71,849.15	132,401.20	132,401.20	8.00		0.00			0.00			0.00			0.00			0.00		
6500	ADMINISTRATIVE/STAFF EXPENSES	18,285.00	10,726.33	-7,558.67	17,250.00	7,428.25			4,874.75			0.00			3,737.00			2,245.00			0.00		
8010	Capital Reserve GWE/Rate Stabilization	0.00	0.00	0.00	0.00	0.00	0.00%		0.00	100.00%	Use not contribution	0.00			0.00			0.00			0.00		
	<b>TOTAL EXPENSES:</b>	<b>4,089,257.86</b>	<b>2,551,930.28</b>	<b>-1,537,327.58</b>	<b>3,932,139.40</b>	<b>588,659.17</b>			<b>1,529,286.39</b>			<b>193,532.11</b>			<b>614,375.86</b>			<b>724,422.28</b>			<b>823,672.50</b>		
	Operating Revenue	4,527,961.52	3,677,964.72	-849,996.80	4,614,564.60	501,108.40			1,525,310.43			263,042.69			710,500.00			715,500.00			812,500.00		
	<b>NET OPERATING REVENUE</b>	<b>438,703.66</b>	<b>1,126,034.44</b>	<b>687,330.78</b>	<b>-87,550.76</b>	<b>-87,550.76</b>			<b>-3,975.95</b>			<b>69,510.58</b>			<b>96,124.14</b>			<b>(8,922.28)</b>			<b>-11,172.50</b>		Significant Carryover
	OVERHEAD																						From Prior year
	<b>NET GENERAL FUND ANNUAL</b>																						

GL ACCT:	GL DESCRIPTION:	Approved 2021-2022 Budget	Expended/ Received to Date as of 03/16/22	Actual Over/Under Budget	Projected Annual Costs (7/1/21- 6/30/22)	GENERAL FUND			GROUNDWATER RECHARGE ENTERPRISE			REDLANDS PLAZA & LEASED PROPERTY- MENTONE HOUSE			LAND RESOURCE			ACTIVE RECHARGE TRANSFER PROJECTS				
						2021 BUDGET:	% BUDGET	BASIS:	2021 BUDGET:	% BUDGET	BASIS:	2021 BUDGET:	% BUDGET	BASIS:	2021 BUDGET:	% BUDGET	BASIS:	2021 Budget	% BUDGET	BASIS:		
<b>Approved 2021-2022 Budget</b>																						
<b>Multiyear Capital projects</b>																						
7010	MATERIALS	12,000.00	0.00	-12,000.00	12,000.00	0.00			6,000.00	50.00%	Field Security Changes	0.00			6,000.00	50.00%				0.00		
7100	CAPITAL REPAIRS		19,100.13	-1,029,870.87	1,026,693.32	0.00			736,971.00			25,000.00			287,000.00					0.00		
7110	PROPERTY - CAPITAL REPAIRS	511,971.00	0.00	-511,971.00	511,971.00	0.00			361,971.00	70.70%	CIP #11 #15			150,000.00	29.30%	CIP #14 #34				0.00		
7120	PROPERTY - LAND PURCHASE	0.00	0.00	0.00	22,722.32															0.00		
7130	MENTONE PROPERTY (HOUSE) CAPITAL R	25,000.00	0.00	-25,000.00	25,000.00	0.00			0.00			25,000.00	100.00%	curb/driveway	0.00					0.00		
7140	MENTONE PROPERTY (SHOP) CIP #3 b&c	375,000.00	19,100.13	-355,899.87	330,000.00	0.00			375,000.00	100.00%		0.00			0.00					0.00		
7160	MENDOZA PROPERTY CIP #12	137,000.00	0.00	-137,000.00	137,000.00									137,000.00	100.00%					0.00		
	EQUIPMENT & VEHICLES																					
7200	EQUIPMENT & VEHICLES		38,133.28	20,028.84	99,000.00	7,250.00			5,533.55			0.00		4,320.89						0.00		
7126	ARTP ENGR/PROF SERVICES #23 #31	500,000.00	0.00	-500,000.00	500,000.00	0.00			0.00	0.00%		0.00	0.00%	0.00	0.00%					600,000.00	100%	
7150	MILL CREEK DIVERSION PROJECT CIP #1	1,100,000.00	0.00	-1,100,000.00	1,100,000.00	0.00			1,100,000.00	100.00%	In WIP Acct until completi	0.00		0.00						0.00		
7438	ENGINEERING SERVICES-OTHER	125,000.00	0.00	-125,000.00	125,000.00	0.00			20,000.00	16.00%	Mill Creek O&M Plans	0.00		87,500.00	70.00%	Mill Creek O&M Plans				17,500.00	14%	
<b>CAPITAL EXPENSE</b>		<b>2,804,075.44</b>	<b>57,233.41</b>	<b>-2,746,842.03</b>	<b>2,862,693.32</b>	<b>7,250.00</b>			<b>1,868,504.55</b>			<b>25,000.00</b>			<b>384,820.89</b>					<b>617,500.00</b>		
CAPITAL REVENUE		278,621.92				0.00			128,621.92			0.00		150,000.00							0.00	
CAPITAL SUBTOTAL ANNUAL NET		-2,618,203.52				-7,250.00			-1,739,882.63			-25,000.00		-234,820.89							-617,500.00	
<b>RESERVE CONTRIBUTION OR (-USE)</b>		<b>-2,179,499.86</b>							<b>-94,800.76</b>			<b>44,510.58</b>		<b>-138,696.75</b>							<b>-626,422.28</b>	FROM CAPITAL Reserve ARTP

# San Bernardino Valley Water Conservation District

## Estimated Quarterly Investment Report

Investment Instruments	Beginning Balance as of Jul 1, 2021	3rd Quarter Balance thru Mar 16, 2022	Yield	Cumulative Unrealized Gain (Loss)
<b><u>Pooled Money Investment Accounts</u></b>				
LAIF	\$ 430,623.48	\$ 18,868,485.76	25.00%	\$ -
CalTRUST Short-Term Fund	\$ 3,222,408.78	\$ 3,203,522.97	-20.00%	
<b><u>Investment Accounts</u></b>				
UBS Financial Services				
CDs	\$ 500,681.82	\$ 977,122.19	0.83%	\$ (19,890.31)
Cash Dep Acct	\$ -	\$ 3,987.24		
California Credit Union				
24 Mo. CD cashed out	\$ -	\$ -		
CAMP				
Investment Pool	\$ 18,754,702.89	\$ 18,761,215.44	0.20%	\$ -
<b><u>OPEB-Other Postemployment Benefits</u></b>				
CERBT-CA Employers' Retiree Benefit Trust	\$ 639,697.80	\$ 608,597.34		\$ (59,211.62)
<b>TOTAL</b>	<b>\$ 23,548,114.77</b>	<b>\$ 42,422,930.94</b>		<b>\$ (79,101.93)</b>

**Net Change**

**\$ 18,874,816.17**  
**44.49%**

Banking Institutions	Beginning Balance as of July 1, 2021	3rd Quarter Balance ending Mar 16, 2022
Citizen's Business Bank	\$ 2,306,531.33	\$ 2,343,658.53
<b>Cash and Cash Equivalents</b>	<b>\$ 2,306,531.33</b>	<b>\$ 2,343,658.53</b>
Change in Value		\$ 37,127.20

Description	NAV	Annual Yield	Average Maturity	Shares
LAIF	N/A	0.25%	.85 years (310.25 days)	
CalTrust Short-Term Fund	\$10.05	-20%	.85 years (310.25 days)	319,712.871
CERBT	\$21.13			28,795.870
UBS-CD's	see below			

**UBS Investments**

Certificates of Deposit (CDs)	Price	Rate	Maturity	Shares	Purchase Price	Market Value as of 03/16/22	CD Length
1. FHLB Bond 4 Yr Step-Up 0.300% Due 09/09/25 Callible 120921 (Cusip: 3130ANRAO)	\$0.969	0.30%	9/9/2025	250,000	\$250,005.25	\$242,182.50	3 yr
2. FHLB Bond Bond (Cusip: 3130APNR2)	\$0.974	1.00%	11/22/2024	250,000	\$250,005.25	\$243,500.00	3 yr
3. Sallie Mae Bank UT US fixed rate CD (Cusip: 795451BA0)	\$0.978	1.00%	12/16/2024	245,000	\$245,000.00	\$239,661.45	3 yr
4. FFCB Bond-2.19% fixed rate CD (Cusip: 3133ENSK7)	\$0.999	1.00%	3/15/2022	252,000	\$252,000.00	\$251,778.24	3 yr
Average	\$0.98	0.83%	<b>Total Interest Withdrawals</b>	<b>\$0.00</b>	TOTAL	\$997,010.50	\$977,122.19
						\$0.00	Accrued Interest



**San Bernardino Valley  
Water Conservation District**

Helping Nature Store Our Water

Memorandum No. 1857

**To: Board of Directors**  
**From: Betsy Miller, Assistant General Manager**  
**Date: April 13, 2022**  
**Subject: Agreement and Election to Prefund Employer Contributions to a Defined Benefit Pension Plan with the California Public Employees' Retirement System (CalPERS) Internal Revenue Code Section 115 California Employers' Pension Prefunding Trust (CEPPT)**

**RECOMMENDATION**

The Finance and Administration Committee recommend the Board: 1) Approve an Agreement and Election to Prefund Employer Contributions to a Defined Benefit Pension Plan; 2) Approve the Delegation of Authority to Request Disbursements to the General Manager; 3) Authorize the Board President to sign the Agreement and all associated documents; and 4) Approve as part of the annual budget an amount of up to two years annual CalPERS regular costs plus \$50,000 for future unfunded liabilities for deposit into the California Employers' Pension Prefunding Trust from reserves.

**BACKGROUND**

This action considers approval of an agreement with CalPERS to participate in the California Employers' Pension Prefunding Trust (CEPPT) in order to pre-fund pension liabilities. Many counties, cities, and Special Districts in California have created IRS Section 115 Trusts which can be used by governments to fund essential governmental functions such as pension liabilities. The advantage of a Section 115 Trust is that the funds deposited may be invested in higher-yielding instruments than allowed by Government Code for Special Districts in California. Funds deposited into a Section 115 Trust are irrevocable and can only be used for the specific purposes for which the trust was created.

Prefunding the pension contribution through this Section 115 Trust fund under CEPPT will allow the District to grow assets for future pension contributions and create a contingency reserve for the future pension payments should Unfunded Actuarial Liabilities (UAL) be identified for the District by CalPERS in the future.

**DISCUSSION**

A Section 115 Irrevocable Trust allows the District to invest assets to fund future pension contributions over shorter time horizons than the pension fund, and to secure potentially better yields than other short-term alternatives such as the Local Agency Investment Fund (LAIF). The District has utilized a Section 115 Irrevocable Trust for Other Post Employment Benefits (retiree health coverage) for the past four years. The CEPPT funds

1630 W. Redlands Blvd, Suite A  
Redlands, CA 92373  
Phone: 909.793.2503  
Fax: 909.793.0188  
www.sbvwd.org Email: info@sbvwd.org

**BOARD OF DIRECTORS**

Division 1:  
Richard Corneille  
Division 2:  
David E. Raley

Division 3:  
Robert Stewart

Division 4:  
John Longville

Division 5:  
Melody McDonald

**GENERAL MANAGER**

Daniel B. Cozad

would be eligible to cover all of the District's defined benefit pension costs or UAL costs at any time, but may not be used for other obligations. CEPPT does not have a minimum contribution or required annual contribution amount, and the District will be able to make deposits into CEPPT at any time.

Staff evaluated two primary administrators of Section 115 Irrevocable Trusts: 1) California Public Employees Retirement System (CalPERS) and 2) Public Agency Retirement Services (PARS). Based on this review, staff found CalPERS to provide the best value and cost-effectiveness. CalPERS is a State agency that does not retain any profit from operation of the Trust. CEPPT is a self-funded, not-for-profit trust in which participant employers pay for all expenses via a participation fee, which is currently 25 basis points of the assets under management or \$2,500 for each one million dollars in managed assets. The District retains the right to terminate or transfer funds to another qualified trust with no termination or transfer fees.

### **Investment Approach:**

As part of the budget process, the District would assess its expected CalPERS normal cost and allocate the same amount for investment in CEPPT, as well as \$50,000 to be used for future unfunded liability payments. Providing excess reserves are available, the District would fund this investment with the equivalent of two years costs for regular PERS payments plus \$50,000 for unfunded liabilities, or \$162,000 in the initial year. This will allow these funds to earn a return while payments are made from the Trust for the following year. During future annual budget processes, if reserves are needed to meet capital or operating costs, contribution may be deferred or eliminated, and CEPPT funds could cover pension costs for at least two years. CEPPT returns have been in the range of 4%-7.6% over the past ten years; with similar returns, staff estimates \$8,000-\$10,000 in annual savings from the use of CEPPT compared to directly funding pension obligations.

### **FISCAL IMPACT**

After initial setup fees of approximately \$1000, the annual investment are estimated at \$500 in CEPPT expenses. Given present yield history, the investments' earnings are expected to exceed those available to California Special Districts by approximately \$8,500 per year.

### **POTENTIAL MOTIONS**

1. Move to 1) Approve an Agreement and Election to Prefund Employer Contributions to a Defined Benefit Pension Plan; 2) Approve the Delegation of Authority to Request Disbursements to the General Manager; 3) Authorize the Board President to sign the Agreement and all associated documents; and 4) Approve as part of the annual budget an amount of up to two years annual CalPERS regular costs plus \$50,000 for future unfunded liabilities for deposit into the California Employers' Pension Prefunding Trust from reserves.
2. Move to direct staff to evaluate alternative investment approaches.
3. Defer action on setting up a CEPPT.

### **ATTACHMENTS OR MATERIALS**

1. Agreement and Election to Prefund Employer Contributions to a Defined Benefit Pension Plan
2. Delegation of Authority to Request Disbursements California Employers' Pension Prefunding Trust (CEPPT)

**CALIFORNIA EMPLOYERS' PENSION PREFUNDING TRUST PROGRAM**

**AGREEMENT AND ELECTION  
OF**

---

(NAME OF EMPLOYER)

**to Prefund Employer Contributions to a Defined Benefit  
Pension Plan**

WHEREAS (1) Government Code (GC) Section 21711(a) establishes in the State Treasury the California Employers' Pension Prefunding Trust Fund (CEPPT), a special trust fund for the purpose of allowing eligible employers to prefund their required pension contributions to a defined benefit pension plan (each an Employer Pension Plan) by receiving and holding in the CEPPT amounts that are intended to be contributed to an Employer Pension Plan at a later date; and

WHEREAS (2) GC Section 21711(b) provides that the California Public Employees' Retirement System (CalPERS) Board of Administration (Board) has sole and exclusive control of the administration and investment of the CEPPT, the purposes of which include, but are not limited to (i) receiving contributions from participating employers; (ii) investing contributed amounts and income thereon, if any, in order to receive yield on the funds; and (iii) disbursing contributed amounts and income thereon, if any, to pay for costs of administration of the CEPPT and to deposit employer contributions into Employer Pension Plans in accordance with their terms; and

WHEREAS (3) \_\_\_\_\_  
(NAME OF EMPLOYER)

(Employer) desires to participate in the CEPPT upon the terms and conditions set by the Board and as set forth herein; and

WHEREAS (4) Employer may participate in the CEPPT upon (i) approval by the Board and (ii) filing a duly adopted and executed Agreement and Election to Prefund Employer Contributions to a Defined Benefit Pension Plan (Agreement) as provided in the terms and conditions of the Agreement; and

WHEREAS (5) The CEPPT is a trust fund that is intended to perform an essential governmental function (that is, the investment of funds by a State, political subdivision or 115 entity) within the meaning of Internal Revenue Code (Code) Section 115 and Internal Revenue Service Revenue Ruling 77-261, and as an Investment Trust Fund, as defined in Governmental Accounting Standards Board (GASB) Statement No. 84, Paragraph 16, for accounting and financial reporting of fiduciary activities from the

external portion of investment pools and individual investment accounts that are held in a trust that meets the criteria in Paragraph 11c(1).

WHEREAS (6) The CEPPT is not a Code Section 401(a) qualified trust and the assets held in the CEPPT are not assets of any Employer Pension Plan or any plan qualified under Code Section 401(a).

NOW, THEREFORE, BE IT RESOLVED THAT EMPLOYER HEREBY MAKES THE FOLLOWING REPRESENTATION AND WARRANTY AND THAT THE BOARD AND EMPLOYER AGREE TO THE FOLLOWING TERMS AND CONDITIONS:

A. Employer Representation and Warranty

Employer hereby represents and warrants that it is the State of California or a political subdivision thereof, or an entity whose income is excluded from gross income under Code Section 115(1).

B. Adoption and Approval of the Agreement; Effective Date; Amendment

(1) Employer's governing body shall elect to participate in the CEPPT by adopting this Agreement and filing with the Board a true and correct original or certified copy of this Agreement as follows:

Filing by mail, send to: CalPERS  
CEPPT  
P.O. Box 1494  
Sacramento, CA 95812-1494

Filing in person, deliver to: CalPERS Mailroom  
CEPPT  
400 Q Street  
Sacramento, CA 95811

(2) Upon receipt of the executed Agreement, and after approval by the Board, the Board shall fix an effective date and shall promptly notify Employer of the effective date of the Agreement. Employer shall provide the Board such other documents as the Board may request, including, but not limited to a certified copy of the resolution(s) of the governing body of Employer authorizing the adoption of the Agreement and documentation naming Employer's successor entity in the event that Employer ceases to exist prior to termination of this Agreement.

(3) The terms of this Agreement may be amended only in writing upon the agreement of both the Board and Employer, except as otherwise provided herein. Any such amendment or modification to this Agreement shall be adopted and executed in the same manner as required for the Agreement. Upon receipt of the executed amendment or modification, the Board shall fix the effective date of the amendment or modification.

(4) The Board shall institute such procedures and processes as it deems necessary to administer the CEPPT, to carry out the purposes of this Agreement, and to maintain the tax-exempt status of the CEPPT. Employer agrees to follow such procedures and processes.

#### C. Employer Reports Provided for the Board's Use in Trust Administration and Financial Reporting and Employer Contributions

(1) Employer shall provide to the Board a defined benefit pension plan cost report on the basis of the actuarial assumptions and methods prescribed by Actuarial Standards of Practice (ASOP) or prescribed by GASB. Such report shall be for the Board's use in trust administration and financial reporting and shall be prepared at least as often as the minimum frequency required by applicable GASB Standards. This defined benefit pension plan cost report may be prepared as an actuarial valuation report or as a GASB compliant financial report. Such report shall be:

- 1) prepared and signed by a Fellow or Associate of the Society of Actuaries who is also a Member of the American Academy of Actuaries or a person with equivalent qualifications acceptable to the Board;
- 2) prepared in accordance with ASOP or with GASB; and
- 3) provided to the Board prior to the Board's acceptance of contributions for the reporting period or as otherwise required by the Board.

(2) In the event that the Board determines, in its sole discretion, that Employer's cost report is not suitable for the Board's purposes and use or if Employer fails to provide a required report, the Board may obtain, at Employer's expense, a report that meets the Board's trust administration and financial reporting needs. At the Board's option, the Board may recover the costs of obtaining the report either by billing and collecting such amount from Employer or through a deduction from Employer's Prefunding Account (as defined in Paragraph D(2) below).

(3) Employer shall notify the Board in writing of the amount and timing of contributions to the CEPPT, which contributions shall be made in the manner established by the Board and in accordance with the terms of this Agreement and any procedures adopted by the Board.

(4) The Board may limit Employer's contributions to the CEPPT to the amount necessary to fully fund the actuarial present value of total projected benefit payments not otherwise prefunded through the applicable Employer Pension Plan (Unfunded PVFB), as set forth in Employer's cost report for the applicable period. If Employer's contribution would cause the assets in Employer's Prefunding Account to exceed the Unfunded PVFB, the Board may refuse to accept the contribution. If Employer's cost report for the applicable period does not set forth the Unfunded PVFB, the Board may

refuse to accept a contribution from Employer if the contribution would cause the assets in Employer's Prefunding Account to exceed Employer's total pension liability, as set forth in Employer's cost report.

(5) No contributions are required. Contributions can be made at any time following the effective date of this Agreement if Employer has first complied with the requirements of this Agreement, including Paragraph C.

(6) Employer acknowledges and agrees that assets held in the CEPPT are not assets of any Employer Pension Plan or any plan qualified under Code Section 401(a), and will not become assets of such a plan unless and until such time as they are distributed from the CEPPT and deposited into an Employer Pension Plan.

#### D. Administration of Accounts; Investments; Allocation of Income

(1) The Board has established the CEPPT as a trust fund consisting of an aggregation of separate single-employer accounts, with pooled administrative and investment functions.

(2) All Employer contributions and assets attributable to Employer contributions shall be separately accounted for in the CEPPT (Employer's Prefunding Account). Assets in Employer's Prefunding Account will be held for the exclusive purpose of funding Employer's contributions to its Employer Pension Plan(s) and defraying the administrative expenses of the CEPPT.

(3) The assets in Employer's Prefunding Account may be aggregated with the assets of other participating employers and may be co-invested by the Board in any asset classes appropriate for a Code Section 115 trust, subject to any additional requirements set forth in applicable law, including, but not limited to, subdivision (d) of GC Section 21711. Employer shall select between available investment strategies in accordance with applicable Board procedures.

(4) The Board may deduct the costs of administration of the CEPPT from the investment income of the CEPPT or from Employer's Prefunding Account in a manner determined by the Board.

(5) Investment income earned shall be allocated among participating employers and posted to Employer's Prefunding Account daily Monday through Friday, except on holidays, when the allocation will be posted the following business day.

(6) If, at the Board's sole discretion and in compliance with accounting and legal requirements applicable to an Investment Trust Fund and to a Code Section 115 compliant trust, the Board determines to its satisfaction that all obligations to pay defined benefit pension plan benefits in accordance with the applicable Employer Pension Plan terms have been satisfied by payment or by defeasance with no remaining risk regarding the amounts to be paid or the value of assets held in the

CEPPT, then the residual Employer assets held in Employer's Prefunding Account may be returned to Employer.

#### E. Reports and Statements

- (1) Employer shall submit with each contribution a contribution report in the form and containing the information prescribed by the Board.
- (2) The Board, at its discretion but at least annually, shall prepare and provide a statement of Employer's Prefunding Account reflecting the balance in Employer's Prefunding Account, contributions made during the period covered by the statement, investment income allocated during such period, and such other information as the Board may determine.

#### F. Disbursements

- (1) Employer may receive disbursements from the CEPPT not to exceed, on an annual basis, the amount of the total annual Employer contributions to Employer's Pension Plan for such year.
- (2) Employer shall notify the Board in writing in the manner specified by the Board of the persons authorized to request disbursements from the CEPPT on behalf of Employer.
- (3) Employer's request for disbursement shall be in writing signed by Employer's authorized representative, in accordance with procedures established by the Board, and the Board may rely conclusively upon such writing. The Board may, but is not required to, require that Employer certify or otherwise demonstrate that amounts disbursed from Employer's Prefunding Account will be used solely for the purposes of the CEPPT. However, in no event shall the Board have any responsibility regarding the application of distributions from Employer's Prefunding Account.
- (4) No disbursement shall be made from the CEPPT which exceeds the balance in Employer's Prefunding Account.
- (5) Requests for disbursements that satisfy the above requirements will be processed on at least a monthly basis.
- (6) The Board shall not be liable for amounts disbursed in error if it has acted upon the written instruction of an individual authorized by Employer to request disbursements, and is under no duty to make any investigation or inquiry about the correctness of such instruction. In the event of any other erroneous disbursement, the extent of the Board's liability shall be the actual dollar amount of the disbursement, plus interest at the actual earnings rate but not less than zero.

## G. Costs of Administration

Employer shall pay its share of the costs of administration of the CEPPT, as determined by the Board and in accordance with Paragraph D.

## H. Termination of Employer's Participation in the CEPPT

(1) The Board may terminate Employer's participation in the CEPPT if:

- (a) Employer's governing body gives written notice to the Board of its election to terminate; or
- (b) The Board determines, in its sole discretion, that Employer has failed to satisfy the terms and conditions of applicable law, this Agreement or the Board's rules, regulations or procedures.

(2) If Employer's participation in the CEPPT terminates for either of the foregoing reasons, all assets in Employer's Prefunding Account shall remain in the CEPPT, except as otherwise provided below, and shall continue to be invested and accrue income as provided in Paragraph D, and Employer shall remain subject to the terms of this Agreement with respect to such assets.

(3) After Employer's participation in the CEPPT terminates, Employer may not make further contributions to the CEPPT.

(4) After Employer's participation in the CEPPT terminates, disbursements from Employer's Prefunding Account may continue upon Employer's instruction or otherwise in accordance with the terms of this Agreement.

(5) After Employer's participation in the CEPPT terminates, the governing body of Employer may request either:

- (a) A trustee to trustee transfer of the assets in Employer's Prefunding Account to a trust dedicated to prefunding Employer's required pension contributions; provided that the Board shall have no obligation to make such transfer unless the Board determines that the transfer will satisfy applicable requirements of the Code, other law and accounting standards, and the Board's fiduciary duties. If the Board determines that the transfer will satisfy these requirements, the Board shall then have one hundred fifty (150) days from the date of such determination to effect the transfer. The amount to be transferred shall be the amount in Employer's Prefunding Account as of the date of the transfer (the "transfer date") and shall include investment earnings up to an investment earnings allocation date preceding the transfer date. In no event shall the investment earnings allocation date precede the transfer date by more than 150 days.

- (b) A disbursement of the assets in Employer's Prefunding Account; provided that the Board shall have no obligation to make such disbursement unless the Board determines that, in compliance with the Code, other law and accounting standards, and the Board's fiduciary duties, all of Employer's obligations for payment of defined benefit pension plan benefits and reasonable administrative costs of the Board have been satisfied. If the Board determines that the disbursement will satisfy these requirements, the Board shall then have one hundred fifty (150) days from the date of such determination to effect the disbursement. The amount to be disbursed shall be the amount in Employer's Prefunding Account as of the date of the disbursement (the "disbursement date") and shall include investment earnings up to an investment earnings allocation date preceding the disbursement date. In no event shall the investment earnings allocation date precede the disbursement date by more than 150 days.

(6) After Employer's participation in the CEPPT terminates and at such time that no assets remain in Employer's Prefunding Account, this Agreement shall terminate. To the extent that assets remain in Employer's Prefunding Account, this Agreement shall remain in full force and effect.

(7) If, for any reason, the Board terminates the CEPPT, the assets in Employer's Prefunding Account shall be paid to Employer to the extent permitted by law and Code Section 115 after retention of (i) an amount sufficient to pay the Unfunded PVFB as set forth in a current defined benefit pension plan(s) cost report prepared in compliance with ASOP and the requirements of Paragraph C(1), and (ii) amounts sufficient to pay reasonable administrative costs of the Board. Amounts retained by the Board to pay the Unfunded PVFB shall be transferred to (i) another Code Section 115 trust dedicated to prefunding Employer's required pension contributions, subject to the Board's determination that such transfer will satisfy applicable requirements of the Code, other law and accounting standards, and the Board's fiduciary duties or (ii) Employer's Pension Plan, subject to acceptance by Employer's Pension Plan.

(8) If Employer ceases to exist but Employer's Prefunding Account continues to exist, and if no provision has been made to the Board's satisfaction by Employer with respect to Employer's Prefunding Account, the Board shall be permitted to identify and appoint a successor to Employer under this Agreement, provided that the Board first determines, in its sole discretion, that there is a reasonable basis upon which to identify and appoint such a successor and provided further that such successor agrees in writing to be bound by the terms of this Agreement. If the Board is unable to identify or appoint a successor as provided in the preceding sentence, then the Board is authorized to appoint a third-party administrator or other successor to act on behalf of Employer under this Agreement and to otherwise carry out the intent of this Agreement with respect to Employer's Prefunding Account. Any and all costs associated with such appointment shall be paid from the assets attributable to Employer's Prefunding Account. At the Board's option, and subject to acceptance by Employer's Pension Plan,

the Board may instead transfer the assets in Employer's Prefunding Account to Employer's Pension Plan and terminate this Agreement.

(9) If the Board determines, in its sole discretion, that Employer has breached the representation and warranty set forth in Paragraph A., the Board shall take whatever action it deems necessary to preserve the tax-exempt status of the CEPPT.

I. Indemnification

Employer shall indemnify, defend, and hold harmless CalPERS, the Board, the CEPPT, and all of the officers, trustees, agents and employees of the foregoing from and against any loss, liability, claims, causes of action, suits, or expense (including reasonable attorneys' fees and defense costs, lien fees, judgments, fines, penalties, expert witness fees, appeals, and claims for damages of any nature whatsoever) not charged to the CEPPT and imposed as a result of, arising out of, related to or in connection with (1) the performance of the Board's duties or responsibilities under this Agreement, except to the extent that such loss, liability, suit or expense results or arises from the Board's own gross negligence, willful misconduct or material breach of this Agreement, or (2) without limiting the scope of Paragraph F(6) of this Agreement, any acts taken or transactions effected in accordance with written directions from Employer or any of its authorized representatives or any failure of the Board to act in the absence of such written directions to the extent the Board is authorized to act only at the direction of Employer.

J. General Provisions

(1) Books and Records

Employer shall keep accurate books and records connected with the performance of this Agreement. Such books and records shall be kept in a secure location at Employer's office(s) and shall be available for inspection and copying by the Board and its representatives.

(2) Notice

(a) Any notice or other written communication pursuant to this Agreement will be deemed effective immediately upon personal delivery, or if mailed, three (3) days after the date of mailing, or if delivered by express mail or e-mail, immediately upon the date of confirmed delivery, to the following:

For the Board:

Filing by mail, send to:  
CalPERS  
CEPPT  
P.O. Box 1494  
Sacramento, CA 95812-1494

Filing in person, deliver to:  
CalPERS Mailroom  
CEPPT  
400 Q Street  
Sacramento, CA 95811

For Employer:

(b) Either party to this Agreement may, from time to time by notice in writing served upon the other, designate a different mailing address to which, or a different person to whom, all such notices thereafter are to be addressed.

### (3) Survival

All representations, warranties, and covenants contained in this Agreement, or in any instrument, certificate, exhibit, or other writing intended by the parties to be a part of this Agreement shall survive the termination of this Agreement.

### (4) Waiver

No waiver of a breach, failure of any condition, or any right or remedy contained in or granted by the provisions of this Agreement shall be effective unless it is in writing and signed by the party waiving the breach, failure, right, or remedy. No waiver of any breach, failure, right, or remedy shall be deemed a waiver of any other breach, failure, right, or remedy, whether or not similar, nor shall any waiver constitute a continuing waiver unless the writing so specifies.

### (5) Necessary Acts; Further Assurances

The parties shall at their own cost and expense execute and deliver such further documents and instruments and shall take such other actions as may be reasonably required or appropriate to evidence or carry out the intent and purposes of this Agreement.

### (6) Incorporation of Amendments to Applicable Laws and Accounting Standards

Any references to sections of federal or state statutes or regulations or accounting standards shall be deemed to include a reference to any amendments thereof and any successor provisions thereto.

(7) Days

Wherever in this Agreement a set number of days is stated or allowed for a particular event to occur, the days are understood to include all calendar days, including weekends and holidays, unless otherwise stated.

(8) No Third Party Beneficiaries

Except as expressly provided herein, this Agreement is for the sole benefit of the parties hereto and their permitted successors and assignees, and nothing herein, expressed or implied, will give or be construed to give any other person any legal or equitable rights hereunder. Notwithstanding the foregoing, CalPERS, the CEPPT, and all of the officers, trustees, agents and employees of CalPERS, the CEPPT and the Board shall be considered third party beneficiaries of this Agreement with respect to Paragraph I above.

(9) Counterparts

This Agreement may be executed in one or more counterparts, each of which shall be deemed an original, but all of which together shall constitute one and the same instrument.

A majority vote of Employer's Governing Body at a public meeting held on the \_\_\_\_\_ day of the month of \_\_\_\_\_ in the year \_\_\_\_\_, authorized entering into this Agreement.

Signature of the Presiding Officer: \_\_\_\_\_

Printed Name of the Presiding Officer: \_\_\_\_\_

Name of Governing Body: \_\_\_\_\_

Name of Employer: \_\_\_\_\_

Date: \_\_\_\_\_

BOARD OF ADMINISTRATION  
CALIFORNIA PUBLIC EMPLOYEES' RETIREMENT SYSTEM

BY \_\_\_\_\_

ARNITA PAIGE  
DIVISION CHIEF, PENSION CONTRACT AND PREFUNDING PROGRAMS  
CALIFORNIA PUBLIC EMPLOYEES' RETIREMENT SYSTEM

To be completed by CalPERS

The effective date of this Agreement is: \_\_\_\_\_



California Public Employees' Retirement System  
 California Employers' Pension Prefunding Trust (CEPPT)  
 400 Q Street, Sacramento, CA 95811  
 www.calpers.ca.gov

## Delegation of Authority to Request Disbursements California Employers' Pension Prefunding Trust (CEPPT)

### RESOLUTION OF THE

\_\_\_\_\_  
 (GOVERNING BODY)

### OF THE

\_\_\_\_\_  
 (NAME OF EMPLOYER)

The \_\_\_\_\_ delegates to the incumbents  
 (GOVERNING BODY)

in the positions of \_\_\_\_\_ and  
 (TITLE)

\_\_\_\_\_, and/or  
 (TITLE)

\_\_\_\_\_ authority to request on behalf of the  
 (TITLE)

Employer disbursements from the Pension Prefunding Trust and to certify as to the purpose  
 for which the disbursed funds will be used.

By \_\_\_\_\_

Title \_\_\_\_\_

Witness \_\_\_\_\_

Date \_\_\_\_\_



**San Bernardino Valley  
Water Conservation District**

Helping Nature Store Our Water

Memorandum No. 1858

**To: Board of Directors**  
**From: Betsy Miller, Assistant General Manager**  
**Date: April 13, 2022**  
**Subject: Unaudited Financial Reports for March 2022**

---

**RECOMMENDATION**

Review and approve the unaudited financials for March 2022.

**BACKGROUND**

Each month staff presents the unaudited financials for the District. The reports presented today are as of March 31, 2022.

**DISCUSSION**

Interest income remains below budget due to low market investment yields. Mining income continues to be higher than expected as significant construction projects are undertaken in the region. Wash Plan revenue is a combination of both District loans and state permitting revenue received from Wash Plan participants; a reimbursement payment of \$70,099 from City of Redlands is expected soon. GL 6006 Permits includes the District's portion of state permitting costs. GL 6030 Office Supplies is higher than budgeted due to new desks and computers for new staff. All other expenses are as expected.

**FISCAL IMPACT**

There is no fiscal impact from reporting the financial status of the District.

**POTENTIAL MOTIONS**

1. Move approval of the Unaudited Financials for March 2022 as presented.
2. Move to request this item be tabled and referred to Finance & Administration Committee for reconsideration of specific issues.

**ATTACHMENTS OR MATERIALS**

Graph Financials for March 2022  
Profit & Loss to Date vs. Annual Budget

1630 W. Redlands Blvd, Suite A  
Redlands, CA 92373  
Phone: 909.793.2503  
Fax: 909.793.0188  
www.sbvwd.org Email: info@sbvwd.org

**BOARD OF  
DIRECTORS**

Division 1:  
Richard Corneille

Division 2:  
David E. Raley

Division 3:  
Robert Stewart

Division 4:  
John Longville

Division 5:  
Melody McDonald

**GENERAL  
MANAGER**

Daniel B. Cozad

**SBVWCD - All Enterprises Budget and Actual**

**March 2022**

REVENUE	Jul '21-Mar '22	Budget
Total 4010 · Interest Income	\$ (35,326)	\$ 205,095
4021-4023· Groundwater Charge	\$ 618,183	\$ 566,495
4024 · Groundwater Council Revenue	\$ 696,802	\$ 696,800
4025 · Wash Plan Revenue*	\$ 947,563	\$ 165,000
Total 4030 · Mining Income	\$ 687,194	\$ 531,000
4040 · Miscellaneous Income	\$ 5,297	\$ 7,500
4050 · Property Tax	\$ 116,984	\$ 91,572
4055 · SBVMWD Spreading Agreement	\$ 431,811	\$ 421,846
Total 4060 · Property Income	\$ 100	\$ 100
4065 · Redlands Plaza	\$ 130,598	\$ 163,527
4080 · Exchange Plan	\$ -	\$ 30,000
<b>Total Revenue</b>	<b>\$ 3,599,206</b>	<b>\$ 2,878,936</b>

\*District loans to the WP & State Permitting payments

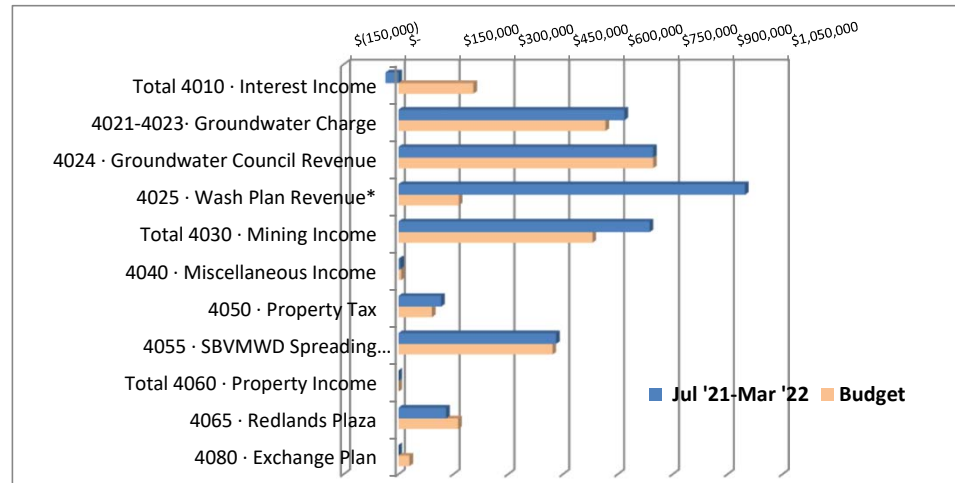

EXPENSES Operating and Capital	Jul '21-Mar '22	Budget
5080 · LAFCO Contribution	\$ 2,419	\$ 2,419
Total 5100 · Professional Service	\$ 620,297	\$ 767,113
Total 5200 · Field Operations (+ GL 5050)	\$ 56,015	\$ 117,900
Total 5300 · Vehicle Operations	\$ 14,810	\$ 17,345
Total 5400 · Utilities	\$ 22,213	\$ 20,995
Total 6000 · General Administration	\$ 343,554	\$ 252,205
Total 6100 · Benefits	\$ 378,099	\$ 540,193
Total 6200 · Salaries	\$ 1,138,593	\$ 1,269,540
Total 6300 · Insurance	\$ 48,992	\$ 37,120
Total 6400 · Board of Directors' Expenses	\$ 65,386	\$ 105,551
Total 6500 · Administrative/Staff Expenses	\$ 10,169	\$ 13,713
<b>Total Expense</b>	<b>\$ 2,700,547</b>	<b>\$ 3,144,093</b>

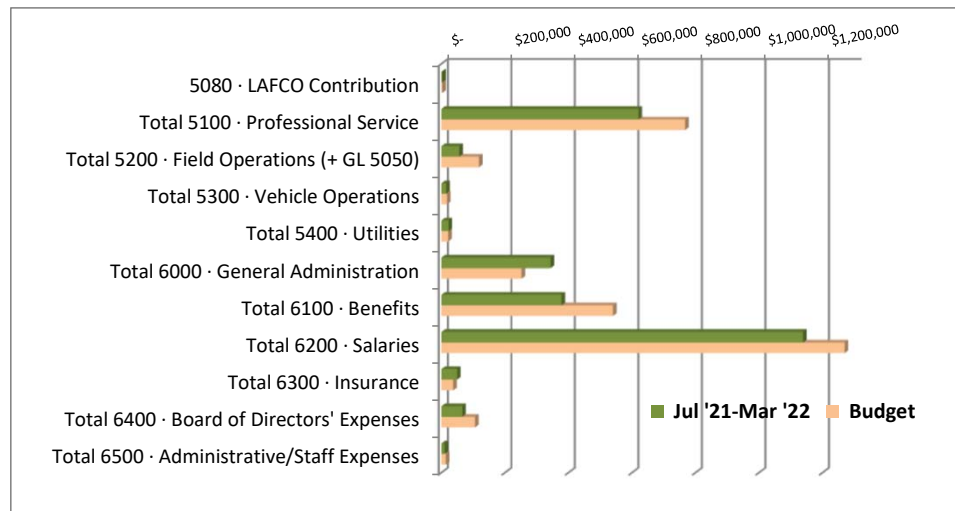

## Enterprises to Date (March 2022)

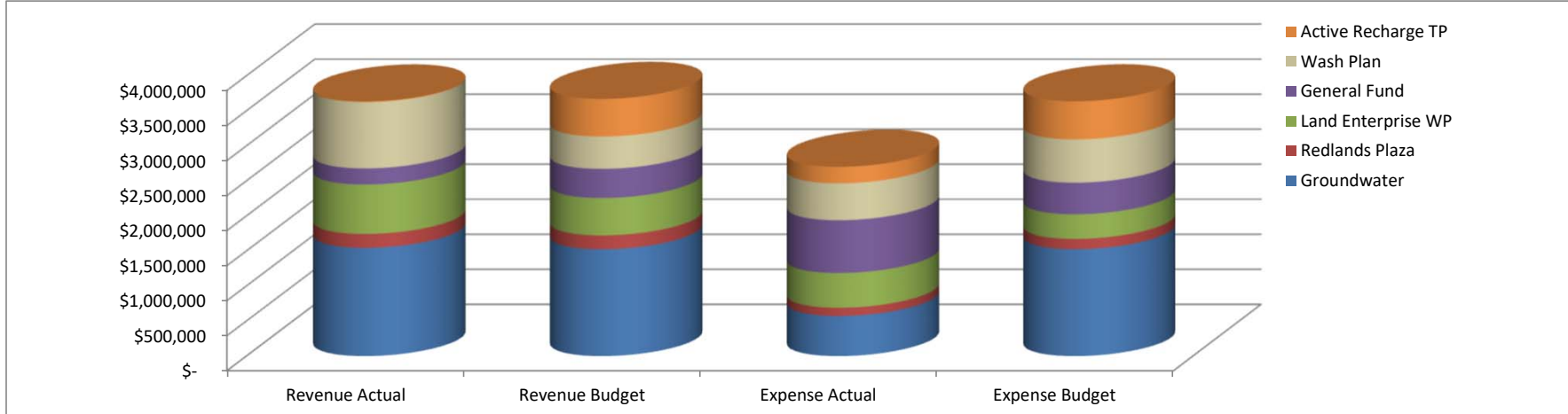

Enterprise	Actual	Budget	% of Budget
Groundwater Revenue	\$ 1,545,781	\$ 1,525,310	101%
Groundwater Expense	\$ 572,971	\$ 1,065,730	54%
Revenue -Expense	\$ 972,810	\$ 459,581	
Redlands Plaza Revenue	\$ 197,296	\$ 197,307	100%
Redlands Plaza Expense	\$ 117,129	\$ 147,585	79%
Revenue -Expense	\$ 80,167	\$ 49,722	
Land Enterprise Revenue	\$ 705,736	\$ 532,875	132%
Land Enterprise Expense	\$ 495,563	\$ 351,595	141%
Revenue -Expense	\$ 210,173	\$ 181,280	
General Fund Revenue *	\$ 229,764	\$ 416,748	55%
General Fund Expense	\$ 753,617	\$ 450,612	167%
Revenue -Expense	\$ (523,853)	\$ (33,864)	
Wash Plan Revenue	\$ 947,563	\$ 461,250	205%
Wash Plan Expense	\$ 526,589	\$ 617,754	85%
Revenue-Expense	420,973	(156,504)	
Active Recharge TP Revenue	\$ 7,906	\$ 536,625	1%
Active Recharge TP Expense	\$ 235,500	\$ 543,317	43%
Revenue-Expense	\$ (227,594)	\$ (6,692)	
Total All Revenue - Expense	\$ 932,677	\$ 493,522	

Cash Status	As of 7/1/2021	As of 03/31/2022
LAIF	\$ 430,623.48	\$ 18,868,485.76
Cal Trust	\$ 3,222,408.78	\$ 3,204,378.65
Citizens Bank	\$ 2,306,531.33	\$ 2,212,365.41
UBS Financial Services	\$ 500,681.82	\$ 968,341.76
US Bank-CAMP	\$ 18,754,702.89	\$ 18,765,244.10
Total Cash	\$ 25,214,948.30	\$ 44,018,815.68
Less Prepaid Royalty	\$ (5,000,000.00)	\$ (5,000,000.00)
Less ARTP Obligation	\$ (18,437,500.00)	\$ (36,591,647.27)
<b>Cash Position</b>	<b>\$ 1,777,448.30</b>	<b>\$ 2,427,168.41</b>

Increase (decrease) of \$649,720.11  
Percent Increase 36.6%

\* General Fund Revenue shown here does not include overhead

San Bernardino Valley Water Conservation District  
Profit & Loss To Date vs. Annual Budget

	<u>Jul '21 - Mar 22</u>	<u>Budget</u>	<u>\$ Over Budget</u>	<u>% of Budget</u>
<b>Ordinary Income/Expense</b>				
<b>Income</b>				
<b>4010 · Interest Income</b>				
4012 · LAIF	510.69	4,000.00	-3,489.31	12.77%
4013 · Caltrust Investment Income	-18,030.13	25,600.00	-43,630.13	-70.43%
4014 · CalCredit Union Interest Income	0.00	0.00	0.00	0.0%
4015 · UBS Interest Income	-28,347.54	27,860.00	-56,207.54	-101.75%
4016 · Interest Income ARTP	10,541.21	216,000.00	-205,458.79	4.88%
4010 · Interest Income - Other	0.00	0.00	0.00	0.0%
<b>Total 4010 · Interest Income</b>	<b>-35,325.77</b>	<b>273,460.00</b>	<b>-308,785.77</b>	<b>-12.92%</b>
4017 · ARTP Capital Income	0.00	615,000.00	-615,000.00	0.0%
<b>4020 · Groundwater Charge</b>				
4021 · Assessments - Ag	57,376.62	0.00	57,376.62	100.0%
4022 · Groundwater Charge	328,686.23	549,681.07	-220,994.84	59.8%
4023 · Assessments - Non-Ag	218,675.96	0.00	218,675.96	100.0%
4024 · Groundwater Council Revenue	696,802.00	696,800.00	2.00	100.0%
4026 · GW Sustainability/Replenishment	13,444.51	16,814.00	-3,369.49	79.96%
<b>Total 4020 · Groundwater Charge</b>	<b>1,314,985.32</b>	<b>1,263,295.07</b>	<b>51,690.25</b>	<b>104.09%</b>
4025 · Wash Plan Revenue	947,562.65	220,000.00	727,562.65	430.71%
<b>4030 · Mining Income</b>				
4031 · Plant Site - CEMEX	28,000.00	48,000.00	-20,000.00	58.33%
4032 · Cemex - Royalty / Lease	589,501.22	600,000.00	-10,498.78	98.25%
4036 · Aggregate Maintenance	69,692.69	60,000.00	9,692.69	116.15%
<b>Total 4030 · Mining Income</b>	<b>687,193.91</b>	<b>708,000.00</b>	<b>-20,806.09</b>	<b>97.06%</b>
<b>4040 · Miscellaneous Income</b>				
4041 · Reimbursed Expenses	157.36	0.00	157.36	100.0%
4040 · Miscellaneous Income - Other	5,139.89	10,000.00	-4,860.11	51.4%
<b>Total 4040 · Miscellaneous Income</b>	<b>5,297.25</b>	<b>10,000.00</b>	<b>-4,702.75</b>	<b>52.97%</b>
4043 · Project Salary Reimbursement	6,066.69			
4050 · Property Tax	116,984.42	130,817.65	-13,833.23	89.43%
4055 · SBVMWD Spreading Agreement Reim	431,810.98	421,846.11	9,964.87	102.36%
<b>4060 · Property Income</b>				
4062 · Mentone Property	100.00	100.00	0.00	100.0%
<b>Total 4060 · Property Income</b>	<b>100.00</b>	<b>100.00</b>	<b>0.00</b>	<b>100.0%</b>
4065 · Redlands Plaza	130,597.66	218,036.34	-87,438.68	59.9%
4066 · Redlands Plaza CAM	28,773.25	44,906.35	-16,133.10	64.07%
4080 · Exchange Plan	0.00	30,000.00	-30,000.00	0.0%
4086 · Plunge Creek IRWMP	0.00	0.00	0.00	0.0%
4999 · Trust Reimbursement-Wash Plan	0.00	592,500.00	-592,500.00	0.0%
<b>Total Income</b>	<b>3,634,046.36</b>	<b>4,527,961.52</b>	<b>-893,915.16</b>	<b>80.26%</b>
<b>Gross Profit</b>	<b>3,634,046.36</b>	<b>4,527,961.52</b>	<b>-893,915.16</b>	<b>80.26%</b>
<b>Expense</b>				
<b>5040 · Regional Programs</b>				
5080 · LAFCO Contribution	2,418.94	2,418.94	0.00	100.0%
<b>Total 5040 · Regional Programs</b>	<b>2,418.94</b>	<b>2,418.94</b>	<b>0.00</b>	<b>100.0%</b>
5050 · Basin Cleaning	0.00	50,000.00	-50,000.00	0.0%
<b>5100 · Professional Service</b>				
5120 · Misc. Professional Services	216,731.85	300,000.00	-83,268.15	72.24%
<b>5122 · Wash Plan Professional Services</b>				
5122.01 · Professional Services-Wash Plan	0.00	0.00	0.00	0.0%
5122 · Wash Plan Professional Services - Other	292,852.15	245,000.00	47,852.15	119.53%
<b>Total 5122 · Wash Plan Professional Services</b>	<b>292,852.15</b>	<b>245,000.00</b>	<b>47,852.15</b>	<b>119.53%</b>
5123 · Habitat Management-WP	66,502.92	346,250.00	-279,747.08	19.21%
5124 · Plunge Creek Prof Services	0.00	0.00	0.00	0.0%
5125 · Engineering Services	0.00	30,000.00	-30,000.00	0.0%
5130 · Aerial Photography & Surveying	0.00	2,200.00	-2,200.00	0.0%
5155 · WP Trails Professional Services	0.00	25,000.00	-25,000.00	0.0%
5160 · IT Support	4,297.50	8,500.00	-4,202.50	50.56%
5170 · Audit	24,500.00	26,900.00	-2,400.00	91.08%
5175 · Legal - Wash Plan	13,387.50	5,000.00	8,387.50	267.75%
5180 · Legal	2,025.00	25,000.00	-22,975.00	8.1%
<b>Total 5100 · Professional Service</b>	<b>620,296.92</b>	<b>1,013,850.00</b>	<b>-393,553.08</b>	<b>61.18%</b>
5133 · Regional River HCP Contribution	0.00	25,000.00	-25,000.00	0.0%
<b>5200 · Field Operations</b>				
5210 · Equipment Maintenance	6,390.06	7,200.00	-809.94	88.75%
5215 · Property Maintenance	3,194.35	40,000.00	-36,805.65	7.99%
5225 · Field Clean Up-Illegal dumping	46,430.81	60,000.00	-13,569.19	77.39%
<b>Total 5200 · Field Operations</b>	<b>56,015.22</b>	<b>107,200.00</b>	<b>-51,184.78</b>	<b>52.25%</b>
5223 · Temp. Field Labor	822.60	10,000.00	-9,177.40	8.23%

San Bernardino Valley Water Conservation District  
Profit & Loss To Date vs. Annual Budget

	<u>Jul '21 - Mar 22</u>	<u>Budget</u>	<u>\$ Over Budget</u>	<u>% of Budget</u>
<b>5300 · Vehicle Operations</b>				
5310 · Vehicle Maintenance	3,269.34	8,000.00	-4,730.66	40.87%
5320 · Fuel	11,540.46	15,125.00	-3,584.54	76.3%
<b>Total 5300 · Vehicle Operations</b>	<b>14,809.80</b>	<b>23,125.00</b>	<b>-8,315.20</b>	<b>64.04%</b>
<b>5400 · Utilities</b>				
5410 · Alarm Service	1,468.50	1,545.00	-76.50	95.05%
5420 · Electricity	7,665.44	7,563.42	102.02	101.35%
5430 · Mobile Phone	4,080.00	5,370.31	-1,290.31	75.97%
5440 · Telephone	3,533.66	6,000.00	-2,466.34	58.89%
5450 · Natural Gas	936.44	1,155.00	-218.56	81.08%
5460 · Water / Trash / Sewer	2,904.28	3,609.90	-705.62	80.45%
5470 · Internet Services	1,624.71	2,750.00	-1,125.29	59.08%
<b>Total 5400 · Utilities</b>	<b>22,213.03</b>	<b>27,993.63</b>	<b>-5,780.60</b>	<b>79.35%</b>
<b>6000 · General Administration</b>				
6001 · General Administration - Other	2,620.23	4,500.00	-1,879.77	58.23%
6002 · Website Administration	3,575.91	6,000.00	-2,424.09	59.6%
6004 · Meeting Expenses	1,487.12	2,060.00	-572.88	72.19%
6006 · Permits	170,421.33	45,000.00	125,421.33	378.71%
6007 · Inter District Costs	0.00	10,000.00	-10,000.00	0.0%
6009 · Licenses	1,627.62	1,712.06	-84.44	95.07%
6010 · Surety Bond	3,025.00	1,900.00	1,125.00	159.21%
6012 · Office Maintenance	151.73	2,550.80	-2,399.07	5.95%
6013 · Office Lease Payment	37,500.03	50,000.00	-12,499.97	75.0%
6015 · Mentone House Maintenance	408.00	3,500.00	-3,092.00	11.66%
6016 · Redlands Plaza Maintenance	12,190.73	35,000.00	-22,809.27	34.83%
6018 · Janitorial Services	6,580.00	10,400.00	-3,820.00	63.27%
6019 · Janitorial Supplies	204.24	515.00	-310.76	39.66%
6020 · Vacancy Marketing-Redlands Plaz	0.00	5,000.00	-5,000.00	0.0%
6024 · Computer Equip Maint.	0.00			
6026 · Redlands Plaza CAM expenses	33,698.67	32,936.31	762.36	102.32%
6027 · Computer Software	3,712.60	2,000.00	1,712.60	185.63%
6030 · Office Supplies	6,896.78	3,500.00	3,396.78	197.05%
6033 · Office Equipment Rental	3,428.21	9,500.00	-6,071.79	36.09%
6036 · Printing	2,809.02	2,000.00	809.02	140.45%
6039 · Postage and Overnight Delivery	678.49	1,200.00	-521.51	56.54%
6042 · Payroll Processing	2,581.40	2,859.13	-277.73	90.29%
6045 · Bank Service Charges	0.00	1,000.00	-1,000.00	0.0%
6051 · Uniforms	1,423.59	3,025.00	-1,601.41	47.06%
6060 · Outreach	10,416.99	63,000.00	-52,583.01	16.54%
6087 · Educational Reimbursement	0.00	5,000.00	-5,000.00	0.0%
6090 · Subscriptions/Publications	2,355.04	1,355.20	999.84	173.78%
6091 · Public Notices	2,721.00	3,200.00	-479.00	85.03%
6093 · Memberships	33,040.33	25,289.23	7,751.10	130.65%
<b>Total 6000 · General Administration</b>	<b>343,554.06</b>	<b>334,002.73</b>	<b>9,551.33</b>	<b>102.86%</b>
<b>6100 · Benefits</b>				
6110 · Vision Insurance	2,153.06	3,433.34	-1,280.28	62.71%
6120 · Workers' Comp. Insurance	8,780.02	19,735.34	-10,955.32	44.49%
6130 · Dental Insurance	7,879.38	12,567.32	-4,687.94	62.7%
6150 · Medical Insurance				
6150.01 · Medical Employee Contribution	-21,241.63	-31,135.80	9,894.17	68.22%
6150 · Medical Insurance - Other	172,588.96	285,106.20	-112,517.24	60.54%
<b>Total 6150 · Medical Insurance</b>	<b>151,347.33</b>	<b>253,970.40</b>	<b>-102,623.07</b>	<b>59.59%</b>
6160 · Payroll Taxes-Employer	70,731.33	122,654.27	-51,922.94	57.67%
6170 · PERS Retirement				
6170.01 · PERS Employee Contributions	-150,181.89	-45,326.72	-104,855.17	331.33%
6170 · PERS Retirement - Other	287,390.24	353,223.42	-65,833.18	81.36%
<b>Total 6170 · PERS Retirement</b>	<b>137,208.35</b>	<b>307,896.70</b>	<b>-170,688.35</b>	<b>44.56%</b>
<b>Total 6100 · Benefits</b>	<b>378,099.47</b>	<b>720,257.37</b>	<b>-342,157.90</b>	<b>52.5%</b>
6185 · Actuarial expense	0.00	0.00	0.00	0.0%
6186 · Actuarial Expense-OPEB	0.00	0.00	0.00	0.0%
<b>6200 · Salaries</b>				
6230 · Regular Salaries	1,138,593.14	1,692,720.61	-554,127.47	67.26%
6200 · Salaries - Other	0.00	0.00	0.00	0.0%
<b>Total 6200 · Salaries</b>	<b>1,138,593.14</b>	<b>1,692,720.61</b>	<b>-554,127.47</b>	<b>67.26%</b>
<b>6300 · Insurance</b>				
6310 · Property/ Auto Insurance	4,828.74	4,420.14	408.60	109.24%
6320 · General Liability Insurance	44,163.41	33,651.74	10,511.67	131.24%
<b>Total 6300 · Insurance</b>	<b>48,992.15</b>	<b>38,071.88</b>	<b>10,920.27</b>	<b>128.68%</b>

San Bernardino Valley Water Conservation District  
Profit & Loss To Date vs. Annual Budget

	<u>Jul '21 - Mar 22</u>	<u>Budget</u>	<u>\$ Over Budget</u>	<u>% of Budget</u>
6400 · Board of Directors' Expenses				
6401 · Directors' Fees				
6401.5 · Payroll Taxes-Directors	7,228.77	0.00	7,228.77	100.0%
6401 · Directors' Fees - Other	49,687.00	87,901.20	-38,214.20	56.53%
<b>Total 6401 · Directors' Fees</b>	<b>56,915.77</b>	<b>87,901.20</b>	<b>-30,985.43</b>	<b>64.75%</b>
6410 · Mileage	388.18	4,000.00	-3,611.82	9.71%
6415 · Air Fare	0.00	2,500.00	-2,500.00	0.0%
6420 · Other Travel	0.00	500.00	-500.00	0.0%
6425 · Meals	1,860.61	3,500.00	-1,639.39	53.16%
6430 · Lodging	1,766.07	4,000.00	-2,233.93	44.15%
6435 · Conf/Seminar Registrations	4,455.00	5,000.00	-545.00	89.1%
6440 · Election Fees / Re-Districting	0.00	25,000.00	-25,000.00	0.0%
<b>Total 6400 · Board of Directors' Expenses</b>	<b>65,385.63</b>	<b>132,401.20</b>	<b>-67,015.57</b>	<b>49.38%</b>
6500 · Administrative/Staff Expenses				
6510 · Mileage	1,007.47	2,500.00	-1,492.53	40.3%
6515 · Air Fare	587.13	4,500.00	-3,912.87	13.05%
6520 · Travel, Other (rental car, taxi)	383.79	1,500.00	-1,116.21	25.59%
6525 · Meals	3,134.90	2,035.00	1,099.90	154.05%
6530 · Lodging	2,675.56	3,750.00	-1,074.44	71.35%
6535 · Conf/Seminar Registrations	2,380.00	4,000.00	-1,620.00	59.5%
<b>Total 6500 · Administrative/Staff Expenses</b>	<b>10,168.85</b>	<b>18,285.00</b>	<b>-8,116.15</b>	<b>55.61%</b>
6700 · Depreciation Expense	0.00	0.00	0.00	0.0%
9999 · Contribution to Capital Maint.	0.00	278,621.92	-278,621.92	0.0%
<b>Total Expense</b>	<b>2,701,369.81</b>	<b>4,473,948.28</b>	<b>-1,772,578.47</b>	<b>60.38%</b>
Net Ordinary Income	932,676.55	54,013.24	878,663.31	1,726.76%
Other Income/Expense				
Other Expense				
7000 · Construction				
7010 · Materials	0.00	12,000.00	-12,000.00	0.0%
7055 · Plunge Creek Expansion	0.00	0.00	0.00	0.0%
<b>Total 7000 · Construction</b>	<b>0.00</b>	<b>12,000.00</b>	<b>-12,000.00</b>	<b>0.0%</b>
7100 · Land & Buildings				
7110 · Property Capital Repairs	0.00	511,971.00	-511,971.00	0.0%
7120 · Property-Land Purchase	0.00	0.00	0.00	0.0%
7126 · ARTP Engr/Prof Services	0.00	600,000.00	-600,000.00	0.0%
7130 · Mentone Property (House)-CapRep	0.00	25,000.00	-25,000.00	0.0%
7140 · Mentone Property (Shop)-CapRep	32,668.28	375,000.00	-342,331.72	8.71%
7150 · Mill Creek Diversion	0.00	1,100,000.00	-1,100,000.00	0.0%
7160 · Mendoza Property	0.00	137,000.00	-137,000.00	0.0%
<b>Total 7100 · Land &amp; Buildings</b>	<b>32,668.28</b>	<b>2,748,971.00</b>	<b>-2,716,302.72</b>	<b>1.19%</b>
7200 · Equipment & Vehicles				
7210 · Computer Hardware-Capital Purch	16,419.69	5,000.00	11,419.69	328.39%
7220 · Computer Software	18,448.21	10,000.00	8,448.21	184.48%
7230 · Field Equipment / Vehicles	1,631.37	1,604.44	26.93	101.68%
7240 · Office Equipment	5,688.89	1,500.00	4,188.89	379.26%
<b>Total 7200 · Equipment &amp; Vehicles</b>	<b>42,188.16</b>	<b>18,104.44</b>	<b>24,083.72</b>	<b>233.03%</b>
7400 · Professional Services Capital				
7438 · Engineering Services-Other	0.00	125,000.00	-125,000.00	0.0%
<b>Total 7400 · Professional Services Capital</b>	<b>0.00</b>	<b>125,000.00</b>	<b>-125,000.00</b>	<b>0.0%</b>
<b>Total Other Expense</b>	<b>74,856.44</b>	<b>2,904,075.44</b>	<b>-2,829,219.00</b>	<b>2.58%</b>
Net Other Income	-74,856.44	-2,904,075.44	2,829,219.00	2.58%
<b>Net Income</b>	<b>857,820.11</b>	<b>-2,850,062.20</b>	<b>3,707,882.31</b>	<b>-30.1%</b>



**San Bernardino Valley  
Water Conservation District**  
Helping Nature Store Our Water

Memorandum No. 1859

To: Board of Directors

From: Ad Hoc Audit Selection Committee  
Betsy Miller, Assistant General Manager

Date: April 13, 2022

Subject: Auditor Procurement and Selection for 2022

**RECOMMENDATION**

The Ad Hoc Audit Selection Committee recommends the selection of Rogers, Anderson, Malody and Scott (RAMS) as the District’s Auditor for the 2022 audit and authorization of the General Manager to enter into an agreement for an amount not to exceed \$27,550 for the 2021-2022 audit. The agreement may be extended two additional years based on performance.

**BACKGROUND**

Staff developed and issued a Request for Proposals (RFP) for Audit Services for the District in January 2022, which was forwarded directly to fifteen firms as well as posted to the District website; proposals were due by February 11, 2022. On March 9, 2022, the President appointed an Ad Hoc Audit Committee to review the proposals.

Four proposals were received from the following firms:

Firm Name	Cost	Notes
Rogers, Anderson, Malody & Scott, LLP	\$27,550	
DavisFarr	\$18,900	Did not include closing support
Fechter & Company CPAs	\$27,000	
Harshwall & Company LLP	\$20,160	

All proposals were received in a timely manner and appeared to contain all required items for review. The proposals were distributed to the Ad Hoc Committee for review and evaluation.

**COMMITTEE RECOMMENDATION**

The Ad Hoc Audit Committee convened on March 30, 2022, to review the proposals. Ad Hoc Audit Committee members and select District staff scored and ranked each proposal separately based on the evaluation criteria in

1630 W. Redlands Blvd, Suite A  
Redlands, CA 92373  
Phone: 909.793.2503  
Fax: 909.793.0188  
www.sbvwd.org Email: info@sbvwd.org

<b>BOARD OF DIRECTORS</b>	Division 3: Robert Stewart	<b>GENERAL MANAGER</b>
Division 1: Richard Corneille	Division 4: John Longville	Daniel B. Cozad
Division 2: David E. Raley	Division 5: Melody McDonald	

the RFP. The consensus recommendation of the Ad Hoc Audit Committee is to contract with Rogers, Anderson, Malody & Scott, LLP (RAMS). Generally, Government Code section 12410.6 allows up to six consecutive years for an auditing firm to perform a local agency’s audit services, when the audit partner reviewing the audit, the coordinating audit partner having primary responsibility for the audit, or the audit partner responsible for reviewing the audit has performed such audit services for that agency for six consecutive years. Here, the District has contracted with RAMS for five consecutive years, the upcoming year being the potential sixth. Per the RAMS proposal, the staff at RAMS handling the audit will be different for the upcoming year, however. This is reflected in the chart below:

<b>Auditing Professional</b>	<b>FY 2020 Audit</b>	<b>FY 2021 Audit (Per Proposal)</b>
Engagement Partner	Scott W. Manno, CPA	Gardenya Duran, CPA
Audit Supervisor	Laura Arvizu, CPA	Thao Le, CPA
Concurring Reviewer	Bradferd A. Welebir, CPA	Brianna Schultz, CPA

The recommendation to stay with RAMS, albeit with new staffing, is based primarily on the forthcoming change in District management, RAMS is also the only firm that submitted a proposal that is located within the District’s boundary. Because of the change in staffing, and the break in any continuity, there is no violation of Government Code 12410.6, even if the District opts to stay with the newly proposed RAMS staff beyond this year’s audit.

District staff have had a positive working experience with RAMS over the period of the previous contract, and believe that continuing with the same firm will support the District’s fulfillment of our mission during a time of transition. Staff also noted that limited proposals were received, despite forwarding the RFP directly to multiple firms, possibly due staffing issues at audit firms.

The Committee recommended Harshwall & Company, LLP as its second choice, noting that this firm is not familiar with the District and is located outside of the District’s boundary in San Diego County.

**ALTERNATIVES**

Potential Board Actions include:

1. Adopting Ad Hoc Audit Selection Committee recommendation to contract with RAMS as the District’s Auditor for the 2021-2022 audit, in an amount not to exceed \$27,550, with authorization to extend the agreement up to two additional years based on performance.
2. Adopting Ad Hoc Audit Selection Committee recommendation to contract with RAMS as the District’s Auditor for the 2021-2022 audit, in an amount not to exceed \$27,550, with direction to staff to post an RFP for a new audit firm for the 2022-2023 audit.
3. Approving a contract with Harshwall & Company, LLC for the 2021-2022 audit in an amount not to exceed \$20,160.
4. Table the issue and refer to the Ad Hoc Audit Committee, Finance & Administration Committee, or to a future Board meeting.

**FISCAL IMPACT**

The cost of the audit, including District closing support, would be \$27,550. The District budget for audit services would increase by \$650.00 over fiscal year 2021-2022.

**POTENTIAL MOTIONS**

1. Adopt the Ad Hoc Audit Selection Committee recommendation to select Rogers, Anderson, Malody and Scott (RAMS) as the District’s Auditor for the 2022 audit, and authorize the General Manager to enter into an agreement for an amount not to exceed \$27,550 for the 2021-2022 audit with approval to extend the contract for two additional years based on performance.
2. Adopt the Ad Hoc Audit Selection Committee recommendation to select Rogers, Anderson, Malody and Scott (RAMS) as the District’s Auditor for the 2022 audit, and authorize the General Manager to enter into an agreement for an amount not to exceed \$27,550 for the 2021-2022 audit with approval to extend the contract for two additional years based on performance. Direct staff to post an RFP for a new audit firm for the 2022-2023 audit.
3. Approve a contract with Harshwall & Company, LLC for the 2021-2022 audit in an amount not to exceed \$20,160.
4. Table the issue and refer to the Ad Hoc Audit Committee, Finance & Administration Committee, or to a future Board meeting.

**APPROVALS**

Recommended by the Ad Hoc Audit Committee

Reviewed by District Counsel



# San Bernardino Valley Water Conservation District

Helping Nature Store Our Water

Memorandum No. 1860

**To:** Board of Directors

**From:** Operations Committee  
Erwin Fogerson, ARTP Engineer  
Katelyn Scholte, Principal Engineer

**Date:** April 13, 2022

**Subject:** Mentone Shop Improvements Construction Award of Contract

---

## **RECOMMENDATION**

1. Accept the bid of CS-NK Construction Services in the amount of \$294,065 for design/build of the Mentone shop.
2. Accept the proposal for \$19,308.40 from CS-NK Construction Services to construct water and electrical service for the new shop.
3. Approve an agreement with CS-NK Construction Services in the amount of \$313,373.40 for design and construction services.
4. Approve a contingency fund, not included in the agreement, of \$7,000 for the design/build phase.
5. Approve a contingency fund, not included in the agreement, of \$29,406 for the construction phase for verified quantity overruns based on unit prices.
6. Authorize the General Manager to approve the expenditure of the contract and contingency funds, if needed, and order any necessary changes or additions in work performed under the contract with CS-NK Construction.
7. Authorize the General Manager to spend up to \$70,000 to obtain permits; install a septic system, additional property fencing, general cabinetry and shelving, fuel and pesticide storage; and perform field testing.
8. Authorize the General Manager to accept the work when completed and execute and file the Notice of Completion.

## **BACKGROUND AND DISCUSSION**

The Mentone shop is located at 2181 Mentone Boulevard in Mentone, California. It includes one main building and five auxiliary sheds in various conditions; the Shop has power and running water but does not have a permanent restroom facility. This location serves as the main office for the District's field team, and typically houses the smaller equipment and light duty vehicles. In addition, this location includes a rental home and an open lot.

Staff initially evaluated costs to install a permanent restroom at the Mentone shop in response to a Board request. Based on this evaluation, re-building or expanding the existing Mentone shop was determined to be more cost-effective than building a stand-alone restroom. A needs analysis completed by staff also concluded that additional equipment storage was needed, along with a shower in the restroom facility due to the use of herbicides. Four of the five auxiliary sheds are in a state of disrepair and should be removed to better protect the equipment they house.

1630 W. Redlands Blvd, Suite A  
Redlands, CA 92373  
Phone: 909.793.2503  
Fax: 909.793.0188  
www.sbvwd.org Email: info@sbvwd.org

### **BOARD OF DIRECTORS**

Division 1:  
Richard Corneille

Division 2:  
David E. Raley

Division 3:  
Robert Stewart

Division 4:  
John Longville

Division 5:  
Melody McDonald

### **GENERAL MANAGER**

Daniel B. Cozad

A Request for Proposals was posted on February 25, 2021, to obtain architectural services to develop the project plans, specifications, and estimates. After further review, it was determined that a design/build approach was more appropriate for this type of project. In order to inform the project scope, Hilltop Geotechnical was hired to complete a geotechnical analysis of the site. Due to the large amount of fill found on-site, the proposed building location was moved to the north end of the property to decrease the required excavation. A design/build Request for Bid (RFB) was posted on January 10, 2022, following review by the Operations Committee. The RFB included base bid items such as engineering, permitting, grading, foundation, stub-outs, and the metal building with doors and insulation as well as optional items such as interior walls, plumbing, electrical, and fixtures. The RFB is available on the District’s website at: <https://www.sbvwd.org/our-district/procurement/6851-notice-inviting-bids-and-contract-documents-mentone-shop-final-jan-2022-1/file>.

Staff received three bids as summarized both below and in the attached bid summary; two of these included all the required items and thus were deemed to be complete bids. The bids received were as follows:

Company Name	Bid Cost	Bid Complete
United Carports Riverside	\$182,840	No
Western Steel Building (CS-NK Construction)	\$294,065	Yes
Facility Buildings and Erectors	\$698,000	Yes

Per direction from the Operations Committee and Board, staff negotiated with CS-NK Construction to refine their bid to include all necessary items of work. That effort resulted in the complete bid shown above of \$294,065.

In addition to the bid items, extension of the electrical and water service from either the existing shop or house to the new building must be completed prior to use of the new facility. An estimate of \$19,308.40 for work related to the extension of utilities has been provided from CS-NK Construction.

Additional work outside of the design/build contract will be needed for full functionality of the new building. These items include: 1) Installation of a septic system; and 2) Relocation of fencing (prior to installation of the new building) on the north side of the property and at the back of the house. Finally, construction permits from the County of San Bernardino will be obtained prior to building installation.

Several project tasks will be accomplished directly by District employees. These tasks include 1) Demolishing the four auxiliary sheds in disrepair; 2) Sealing the openings to the auxiliary sheds attached to the existing shop; 3) Importing base material; 4) Installing cabinetry and shelving in the new building; and 5) Obtaining and installing proper fuel and chemical storage containers.

A summary of the anticipated costs, including those related to items outside the contract appears below.

Estimated total project costs:

Building design build contract	\$294,065
Building contract contingency (10%)	\$29,406
Design phase contingency	\$7,000
Permits	\$6,000
Septic system	\$10,000
Water and electrical service	\$20,000 (to be performed by CS-NK)
Property fencing	\$15,000
Imported base material	\$3,000 (to be performed by Operations staff)
Building Demo (not including carport)	\$3,000 (to be performed by Operations staff)
General cabinetry and shelving	\$10,000
Fuel and pesticide storage	\$3,000
<u>Field testing</u>	<u>\$25,000</u>

**Total project costs: \$425,500 (rounded)**

### **FISCAL IMPACT**

The total estimated cost to complete the construction of a new shop is \$425,500 (see table above). Project costs will be charged to CIP 7140, Mentone Property Shop, which is funded by the Groundwater Recharge Enterprise budget. Currently, \$350,000 was budgeted for the project CIP in Fiscal Year 21/22; therefore, an additional allocation of \$75,500 will be proposed for the Fiscal Year 22/23 CIP budget to fully cover project costs. Additional project implementation costs are not obligated by this contract.

### **POTENTIAL MOTIONS**

1. Accept the Operations Committee recommendation to:
  - a. Accept the bid of CS-NK Construction Services in the amount of \$294,065 for the design/build project.
  - b. Accept the proposal for \$19,308.40 from CS-NK Construction Services to construct water and electrical service to the new shop.
  - c. Approve an agreement with CS-NK Construction Services in the total amount of \$313,373.40 for design and construction services.
  - d. Approve a contingency fund of \$7,000 for the design phase of the project and a contingency fund of \$29,406 for the construction phase of the project.
  - e. Authorize the General Manager to approve the expenditure of the contingency funds, as needed, for verified quantity overruns for this unit priced design-build contract and order any necessary changes or additions in work performed under the contract with CS-NK Construction for the construction phase.
  - f. Authorize the General Manager to spend up to \$70,000 to obtain permits, install a septic system, additional property fencing, general cabinetry and shelving, fuel and pesticide storage, and perform field testing.
  - g. Authorize the General Manager to accept the work when completed and execute and file the Notice of Completion.
2. Move to table the items to a future meeting of the Board or the Operations Committee, noting delays to the project schedule.

### **ATTACHMENTS OR MATERIALS**

1. Draft Design Build Contract with CS-NK Construction for the Mentone Shop Improvement (RFB available on District Website but will be included in the final contract)
2. Mentone Shop Design/Build Bid Summary
3. Preliminary Project Schedule

### **APPROVALS**

District Counsel

# MENTONE SHOP PROJECT

## DESIGN AND CONSTRUCTION SERVICES AGREEMENT

**THIS MENTONE SHOP PROJECT DESIGN AND CONSTRUCTION SERVICES AGREEMENT** (“Agreement”) by and between the **SAN BERNARDINO VALLEY WATER CONSERVATION DISTRICT**, a California Conservation District duly formed and existing under California Water Code sections 74000 et seq. (“District”), and **CS-NK Construction Services**, a California corporation on (“Contractor”), is effective upon signature by District and Contractor.

**NOW THEREFORE, the parties hereto agree as follows:**

### **RECITALS**

1. **Independent Contractor.** Contractor is an independent contractor and not an employee of the District. Contractor shall have no authority to bind the District by any statement, representation, or promise of any kind or nature without first obtaining the District’s written consent.
2. **Coordination with Owner (if not District).** District is the Owner of the Property subject to this Agreement, and shall coordinate with District to secure site access. Additionally, the Contractor is authorized to coordinate directly with the District to ensure diversion flows are maintained in the existing diversion canal as specified on Sheet C1 of the Plans under Construction Schedule Constraints.
3. **Authority.** The parties represent each to the other that the representing party is authorized to enter into this Agreement, that by doing so such party is not in breach or violation of any other contract or agreement, and that the persons executing this Agreement on its behalf have the authority and capacity to do so.
4. **Construction.** Each party represents to the other it has had access to legal counsel in entering into this Agreement, and is doing so freely, willingly, and voluntarily, without coercion or duress. This Agreement shall not be construed against any of the parties based on authorship, and the rule of construing contract ambiguities against the party drafting the contract shall be inapplicable.
5. **Effect of Headings.** The headings used in this Agreement are for convenience only and shall not affect the construction or interpretation this Agreement.
6. **Word Usage.** Unless the context clearly requires otherwise, plural and singular numbers will be considered to include the other; the masculine, feminine, and neuter genders will each be considered to include the others; “shall,” “will,” “must,” “agree,” and “covenants” are each mandatory; “may” is permissive; “or” is not exclusive; and “includes” and “including” are not limiting.
7. **Entire Agreement.** This Agreement constitutes the entire agreement between the parties, supersedes all prior or contemporaneous oral or written agreements between the parties, and may only be amended by an instrument in writing executed by the parties.
8. **Successors and Assigns.** This Agreement shall be binding upon, and inure to the benefit of, the successors and assigns of the parties.
9. **Counterparts.** This Agreement may be executed in counterparts, a facsimile of which shall be deemed an original, and all of which shall together be deemed one and the same instrument.
10. **Governing Law.** This Agreement shall be construed under, and governed by, the laws of the State of California.
11. **Severability.** If any provision of this Agreement is held to be invalid or unenforceable, such invalid or unenforceable provision(s) shall not affect the validity or enforceability of any other provision of this Agreement.

## **SCOPE OF WORK and CONTRACT DOCUMENTS**

Contractor shall furnish all labor, services, materials, equipment and tools of every kind and nature to fully perform in a workmanlike and timely manner the scope of work provided below (“Contract Work”):

Contractor shall perform the Contract Work in strict accordance with the Contract Documents, which are as follows:

This Agreement and all accompanying documents thereto

Notice Inviting Bids

Special Provisions

Preliminary Site Plan, Preliminary Flood Plan and Preliminary Elevations

Instructions to Bidders

Bid Proposal (and “Estimate for supplying water to the new structure on the back of the Property” 2021 Edition of (“Greenbook”) Standard Specifications for Public Works Construction Addenda

All Contract Documents are incorporated herein by reference. Contractor shall not deviate from the Contract Documents without the prior written approval of the District. In the event of a conflict or discrepancy among the Contract Documents, interpretation will be based on the following priorities: (1) this Agreement; (2) the Special Provisions (3) Plans (4) 2021 Edition of (“Greenbook”) Standard Specifications for Public Works Construction.

Contractor shall be responsible for any additional costs, delays or damages caused by deviation from the Contract Documents without the prior written approval of the District. All Contract Work shall be subject to the satisfaction and approval of the District identified above.

A condition precedent to the Contractor receiving a Notice to Proceed for the Contract Work is Contractor’s submission of a signed copy of this Agreement, bonds, insurance certificates requested by the District, a Storm Water Pollution Prevention Plan if required and an updated list of Contractor’s subcontractors and material suppliers on the project.

### **TIME FOR PERFORMANCE AND SCHEDULING**

Contract Time - Contractor shall complete all work within the number of days listed in the Special Provisions after Notice to Proceed from the District has been issued.

Scheduling - Time is of the essence under this Agreement. Contractor shall cooperate with the District in the timely performance of the Contract Work consistent with the attached schedule for the Project. Work shall commence with the completion of the three Notice to Proceed events as listed in the Special Provisions.

The District shall have the right to direct the scheduling of the Contract Work as the District deems to be in the best interest for the Project as a whole, and Contractor shall perform the Contract Work in accordance with the approved schedule so as not to delay, disrupt, or damage the Contract Work. Should Contractor fall behind the approved schedule or if, in the opinion of the District, Contractor is not maintaining a satisfactory rate of progress, the District may direct Contractor to take such action as the District deems necessary to timely perform the Contract Work, including, but not limited to, increasing the number of superintendents, foremen, and laborers, increasing the number of crews, increasing the number of shifts, employing more or better equipment, working overtime, expediting delivery of materials, substituting materials, changing the sequence of performance, or any other increase or acceleration of effort, all of which shall be performed by Contractor at no cost to the District.

In the event the Contract Work is delayed or disrupted by the District, or third parties, Contractor may make a written request to the District for a time extension.

The District may award the Contract during winter months when weather may result in construction delays. In the event that weather conditions result in the loss of working days, as such loss is determined to be reasonable by the District, the Contract Time shall be extended by an equivalent amount of time. If and only if District-approved weather delays result in a loss of twenty (20) working days or more, the District and the Contractor will negotiate an equitable adjustment in cost to compensate for mobilization and standby costs, otherwise only the time for performance will be extended, and then only to the amount equivalent to the number of working days lost to weather.

## SCHEDULE OF PRICES

The Schedule of Prices for the various components of the Contract Work are set out below:

ITEM NO.	BASE BID DESCRIPTION	QTY.	UNIT	UNIT PRICE	TOTAL
1	Preliminary & Final Engineering	1	LS	\$30,000	\$30,000
2	Permitting	1	LS	\$5,000	\$5,000
3	Clearing and Grubbing	1	LS	\$8,932	\$8,932
4	Grading / Subgrade Prep / BMP's (incl over-ex and re-compaction)	1	LS	\$19,128	\$19,128
5	Foundation (including footings)	1	LS	\$29,366	\$29,366
6	Plumbing and Electrical stub outs	1	LS	\$16,809	\$16,809
7	Pre-Engineered Metal Building w/ Rollup Doors	1	LS	\$122,162	\$122,162
8	Pre-Engineered Metal Building Insulation	1	LS	\$10,775	\$10,775
	<b>Total Base Items</b>				<b>\$242,172</b>
<b>ADD / DEDUCT ITEMS (NOT REQUIRED)</b>					
1	Interior Walls	1	LS	\$11,343	\$11,343
1.1	Doors and windows (other than rollup Doors) (see schedule)	1	LS	\$2,404	\$2,404
1.2	Plumbing (complete schedule next sheet)	1	LS	\$4,075	\$4,075
1.3	Electrical	1	LS	\$14,255	\$14,255
1.4	Fixtures (complete schedule next sheet)	1	LS	\$2,789	\$2,789
1.5	Perimeter Walls Interior Lining	1	LS	\$7,843	\$7,843
1.6	*Items for identified in project plans or specifications. Contractor to submit detailed description with bid	1	LS	\$3,551	\$3,551
	other cost not listed in bid or cost that cannot be attached to a single bid item	1	LS	\$5,633	\$5,633
	<b>Total Add / Deduct Items</b>				<b>\$51,893</b>
	<b>TOTAL BID</b>				<b>\$294,065</b>

District may, in its sole discretion, decide whether the items lists as “Add/Deduct Items (Not Required) shall be included in the Contract Work. Such dterminatin shall be made by District in writing before District issues the Notice to Proceed. In addition, the Contract Work shall include the following work items:

Estimate water and electrical service construction:

Equipment rental, trencher	\$2,675.00
Provide material & labor to run 1" PVC pipe w/sleeve from corner of sidewalk and driveway across front of house then downside of house to new structure.	\$3,455.85
Tap into meter at street (if needed)	\$1,650.00
Provide material and labor to change out electrical panel on existing power pole and bury new electrical lines underground in 3" electrical power PVC pipe	\$8,344.67
Run new electrical lines from house to existing power pole (if needed)	\$1,855.00
One (1) helper for electrician 3-8hour days. Prevailing wage.	<u>\$1,327.88</u>
	\$19,308.40

## **PAYMENT**

The District shall pay Contractor for full performance of the Contract Work based on the approved percent completion of the Contract Work in strict compliance with the Contract Documents, less retainage, and subject to any District-approved adjustment to the Contract Price and/or time.

No later than the first (1st) day of each month in which Contractor is continuing to perform the Contract Work, Contractor shall submit to the District the following:

- (1) A payment request for the Contract Work, less retainage, performed during the previous month;
- (2) A schedule of values showing the percentage and amount completed of the Contract Work through the current payment request.
- (3) Conditional waivers and releases upon progress payment from Contractor and Contractor’s subcontractors and material suppliers in a form acceptable to the District; and
- (4) Unconditional waivers and releases upon progress payment from Contractor and, as applicable, Contractor’s subcontractors and material suppliers for the previous payment application in a form acceptable to the District.

The District shall make progress payments to Contractor based upon the monthly progress submittal. District shall pay Contractor an amount, less retention of ten percent (10%), equal to the value of the Contract Work satisfactorily completed by Contractor as documented in the payment request and approved by the District, within thirty (30) business days of the District approval.

Upon satisfactory completion of the Contract Work, including satisfactory completion of any punch list work, Contractor shall submit to the District the following:

- (1) A final payment request for the Contract Work, including previously withheld retainage, completed by Contractor;
- (2) A final schedule of values showing the percentage and amount completed of the Contract Work;

- (3) Conditional waivers and releases upon final payment from Contractor and Contractor's subcontractors and material suppliers;
- (4) Unconditional waivers and releases upon progress payment from Contractor and, as applicable, Contractor's subcontractors and material suppliers for the previous payment application.

In addition to the foregoing, a condition precedent to final payment by the District to Contractor is acceptance by the District of the satisfactory completion of the Contract Work and Contractor's submission of any manuals and warranties applicable to the Contract Work.

The District shall pay Contractor an amount, including previously withheld retention, equal to the value of the unpaid Contract Work satisfactorily completed by Contractor and approved by the District, within thirty (30) business days of the District approval.

No payment, whether a progress payment or final payment shall be construed as an acceptance of defective or incomplete work.

## **INSPECTION AND ACCEPTANCE**

The Contract Work and Contractor's performance of the Contract Work is subject to the District's oversight of the progress, sequencing, and quality of the Contract Work, and the satisfaction and approval by the District of same.

Unless otherwise provided, all equipment, materials, and work shall be subject to inspection and testing by the District. The District will observe the progress and quality of the work and determine, in general, if the work is proceeding in accordance with the intent of the Contract Documents. The District shall not be required to make comprehensive or continuous inspections to check the quality of the work, and shall not be responsible for construction means, methods, techniques, sequences, or procedures, or for safety precautions and programs in connection with the work. Visits and observations made by the District shall not relieve the Contractor of its obligation to conduct comprehensive inspections of the work and to furnish proper materials, labor, equipment, and tools, and perform acceptable work, and to provide adequate safety precautions, in conformance with the intent of the Contract.

Materials, equipment, and workmanship shall be subject to the inspection of, and rejection by, the District if not in conformance with the Contract Documents. Defective materials, equipment, or Contract Work shall be removed from the premises by the Contractor, whether in place or not, and shall be replaced with new and acceptable materials, equipment, or work, at Contractor's expense. Repair of defective materials, equipment, or work shall be subject to the District's acceptance.

Upon substantial completion of the Contract Work, Contractor shall make its own "punch list" of Contract Work which is incomplete, defective, or otherwise not in compliance with the Contract Documents applicable to the Contract Work and shall furnish the punch list to the District. Contractor shall immediately correct all items on its punch list and all items on any other punch list or other list of discrepancies in the Contract Work provided by the District so as to expedite final inspection and acceptance of the project

## **LIQUIDATED DAMAGES**

See Special Provision Section 6.9 (Liquidated Damages). Section 6.9 in the Standard Specifications for Public Works Construction 2021 edition shall apply if Liquidated Damages requirements are not included in the Special Provisions.

## **CHANGES / CLAIMS / RESOLUTION OF CONSTRUCTION CLAIMS**

**Changes.** The District may issue written change orders or written change directives for the Contract Work. Contractor shall be obligated to perform such change orders and change directives and the Schedule of Prices or time for performance may be adjusted as specified in such change orders and change directives. Oral changes to the Contract Work are not valid and Contractor shall

have no claim or entitlement to payment or additional time unless, prior to performance, Contractor receives a written change order or written change directive from the District.

If Contractor requests a written change order but there is a dispute as to whether the work at issue is a change in the Contract Work or there is a dispute as to the price or time associated with such change order, the District may issue a written change directive to the Contractor and the Contractor shall be obligated to perform such change directive without either party admitting liability for the change or waiving their respective rights under this Agreement. Any request by the Contractor for additional compensation or additional time shall be based on Contractor's actual direct costs and actual time incurred with respect to the change in the Contract Work. At the District's request, Contractor shall submit and give the District access to, current, accurate and complete data to substantiate any actual direct costs and any actual time claimed by Contractor.

For any change in the Contract Work initiated by the District, Contractor shall be entitled to an adjustment to the Schedule of Prices or time for performance of the Contract Work, but only to the extent of such adjustments actually received by the District from Contractor. Apart from the Change Order process set out herein, Contractor shall have no right to make any claims against the District for further adjustment to the Schedule of Prices nor the time for performance of the Contract Work.

**Contractor Claims.** Contractor shall give written notice to the District of any claim for compensation, additional compensation, extension of time or other relief of any kind or nature alleged to have been caused in whole or in part by any act or omission by the District. Such written notice shall be provided to District within seven (7) days after commencement of the event giving rise to such claim. Such notice shall state the factual basis for the claim, shall itemize all costs incurred and shall indicate the number and duration of each resulting delay and/or anticipated delay. Contractor shall provide any additional information requested by the District. With respect to any claim caused in whole or in part by any person other than the District, Contractor shall only be entitled to such relief less any costs incurred by the District in connection with such claim.

Contractor acknowledges that the project, and all work to be undertaken pursuant to it, will occur within environmentally sensitive habitat including State and federally listed endangered species. Contractor warrants and represents to the District that it has reviewed the work area, carefully has acquainted itself with the physical and operational constraints posed by the existence of this habitat and the need to conform regulatory requirements governing it, and Contractor assumes any and all risks of additional expenses that may be implicated thereby. No change orders will be granted based upon such costs.

**Dispute Resolution.** Unless otherwise agreed to in writing by the parties, with respect to any claim or dispute of any nature involving the District and Contractor in which the amount claimed by either party is no more than \$50,000, the parties shall first attempt to resolve such claim, informally. If, following a period of thirty (30) days, or such longer period as mutually agreed to by the parties, the parties are unable to resolve the claim informally, the parties agree to mediate the claim before a mediator mutually agreed to by the parties. If, following mediation, the parties are unable to resolve the claim, either party may commence a legal action. The parties agree that the party failing to comply with these dispute resolution procedures shall not be entitled to the recovery of their attorney's fees in a legal action. Provided, however, that the foregoing dispute resolution procedures shall not apply if it would cause a party to be unable to timely foreclose on a mechanics lien, as applicable, or if the District pursues a claim for injunctive relief under the following paragraph.

If the District in its sole and absolute discretion believes that Contractor is not in compliance with any applicable laws, statutes, regulations, ordinances, building codes, permit conditions, recordkeeping and reporting obligations, mitigation measures and other government requirements of every nature applicable to the Contract Work, the District may, but is not obligated to,

immediately commence legal action to obtain injunctive relief (including a temporary restraining order, preliminary injunction and/or permanent injunction) and any related remedies to compel such compliance. The prevailing party in any such action for injunctive relief and any related remedies shall be entitled to the recovery of their attorney's fees, without regard to whether it complied with the dispute resolution process above.

With respect to any claim or dispute of any nature involving the District and Contractor in which the amount claimed by either party exceeds \$50,000, or if amount claimed by either party is no more than \$50,000 and the parties have complied with the foregoing dispute resolution procedures or agreed to waive such procedures in writing, the parties agree that the prevailing party in such dispute shall be entitled to recover its reasonable attorney's fees, adjusted proportionately to the relief obtained by the prevailing party.

## **PREVAILING WAGE**

The Contractor shall comply with the provisions of Sections 1771 and 1774 of the California Labor Code pertaining to the payment of prevailing wage rates, and shall require each of its subcontractors to so comply. Pursuant to Section 1775 of the California Labor Code, the Contractor, and any of its subcontractors, shall forfeit to the District, and the District will withhold from any monies due the Contractor, the amount of any penalties, as determined by the Labor Commissioner, to be assessed for nonpayment of prevailing wage rates.

In accordance with State of California Senate Bill No. 854, Contractor will maintain and will require all subcontractors to maintain valid and current Department of Industrial Relations (DIR) Public Works Contractor registration during the term of this project. Contractor shall notify the District in writing immediately, and in no case more than twenty-four (24) hours, after receiving any information that Contractor's or any of its subcontractor's DIR registration status has been suspended, revoked, expired, or otherwise changed.

Contractor will pay, and will require all subcontractors to pay, all employees on the Contract Work a salary or wage at least equal to the prevailing salary or wage established for such work as set forth in the wage determinations and wage standards applicable to this work. Federal prevailing wage rates apply for federally funded projects. Travel and subsistence pay shall be paid in accordance with Labor Code § 1773.1.

Contractor shall be subject to penalties in accordance with Labor Code of § 1775 for each worker paid (either by Contractor or by any subcontractors) less than the prevailing rate described above on the work provided for in this Contract. In no event shall District be responsible for any such penalties.

Contractor and subcontractors shall comply with Labor Code § 1810 and § 1811 which stipulates that eight hours labor constitutes a legal day's work, and § 1812 which stipulates that the Contractor and subcontractors shall keep an accurate record showing the name of and actual hours worked each calendar day and each calendar week by each worker employed by him or her in connection with the work performed under the terms of the Contract. Failure to comply with these sections of the Labor Code will subject the Contractor to penalty and forfeiture provisions of the Labor Code § 1813. In no event shall District be responsible for any such penalties.

Contractor will comply with the provisions of Labor Code § 1777.5 pertaining to the employment of apprentices to the extent applicable to this Contract.

Contractor, by executing this Contract, hereby certifies:

"I am aware of and will comply with the Labor Code § 3700 by securing payment for and maintaining in full force and effect for the duration of the contract, complete Workers' Compensation Insurance, and shall furnish a Certificate of Insurance to the City before execution of the Contract. The City, its officers, or employees, will not be responsible for any claims in law or equity occasioned by failure of the Contractor to comply with this paragraph."

CONTRACTOR INITIALS: \_\_\_\_\_

Contractor further agrees to require all subcontractors to carry Workers' Compensation Insurance as required by the Labor Code of the State of California.

Contractor shall submit to District monthly Certified Payroll with a daily log of manpower and equipment used on the project with seven days of the end of the month.

### **WORKERS COMPENSATION AND INSURANCE CERTIFICATION**

Before commencing with the Contract Work, Contractor shall obtain and maintain at Contractor's cost until final acceptance of the project, full insurance coverage as set forth herein with insurance carriers with an AM Best rating of no less than A-VII. The insurance required under this section shall not be restricted solely to Contractor's defense and indemnity obligations but are intended to extend to all claims, liability, and loss of whatever nature arising from relating to Contractor, the Contract Work, or this Agreement regardless of the alleged liability or fault of any party indemnified under this Agreement. Each insurance policy shall name the District as an additional insured. Each insurance policy is to provide primary coverage to the District and its elected and appointed boards, officers, agents and employees. It is not secondary or in any way subordinate to any other insurance or coverage maintained by the District

The insurance and defense and indemnity obligations under this Agreement are non-delegable. Contractor shall not subcontract any portion of the Contract Work without retaining absolute responsibility for requiring similar insurance from its Contractors. Contractor's failure to maintain complete insurance shall be deemed a material breach of this Agreement and the District may either terminate this Agreement or provide the required insurance and deduct the cost of same from any payment due to Contractor.

Contractor shall be responsible for payment of all insurance premiums required under this Agreement and shall defend, indemnify and hold harmless the District from and against any claim, loss or damage for which insurance should have been provided under this Agreement.

Contractor shall obtain and maintain the following minimum required insurance:

**Workers' Compensation:** Workers' compensation insurance as required by law.

**Commercial General Liability:** Commercial general liability insurance on a form no less broad than ISO CG 00 01 with insurance coverage of not less than the following minimum amounts of liability:

\$2,000,000 each occurrence

\$2,000,000 general aggregate

\$2,000,000 completed operations aggregate

Contractor shall endorse its commercial general liability policy with an additional insured endorsement on ISO CG 20 10 11 85 or both CG 20 10 12 04 and CG 20 37 12 04 naming as additional insured's the District, the Owner, and Project Sponsor.

**Automobile Liability:** Automobile liability insurance covering "any auto" including owned, non-owned and hired vehicles with a combined single limit of \$1,000,000.

**Professional Liability:** Because Contractor has design responsibilities, professional errors and omissions liability insurance with a limit of \$1,000,000 per claim.

Contractor's commercial general liability, workers compensation, automobile liability and any other insurance policies required to be obtained and maintained by Contractor shall be primary and the District's insurance shall be non-contributory to any claim to which the insurance applies. Contractor shall have its insurance policies endorsed to show primary status and provide a copy to

the District. Contractor's insurance policies shall contain a standard cross-liability endorsement, severability of interest's clause and a waiver of all rights of subrogation by Contractor's insurer against the District, the Owner, and Project Sponsor.

Before commencing the Contract Work, Contractor shall deliver to the District copies of certificates of insurance certifying the types and amounts of coverage, certifying that the insurance policies were in force before Contractor commenced the Contract Work, certifying that the insurance policies apply to the Contract Work and to the activities and liability of Contractor under this Agreement.

Contractor shall, at the District's request, deliver to the District a complete copy of the insurance policy required to be maintained by Contractor. Contractor may not cancel, materially modify, or reduce the scope of coverage or coverage limits of the insurance required to be maintained by Contractor until final acceptance of the Project by the District. The following notice must appear on the certificates of insurance furnished by Contractor and the Contractor shall obtain endorsements to its insurance policies substantially as follows:

Insurer may not cancel, modify or reduce the scope of coverage or coverage limits for a period of third (30) days after written notice to the District of the intent to cancel, modify, or reduce coverage.

**Cancellation of or Changes in Insurance:** The Contractor shall provide the District with, or the Contractor's insurance policies shall contain a provision that the District shall receive, written notice of cancellation or any change in the insurance required in the Specifications, including insurer, limits of coverage, term of coverage, or policy period. The written notice shall be provided to the District at least ten (10) days in advance of cancellation for non-payment of premium and thirty (30) days in advance for any other cancellation or policy change. Failure to provide written notice of cancellation or any change in the insurance required in the Specifications shall constitute a material breach of the Contract, upon which the District may in its sole and absolute discretion suspend or terminate the Contract.

**Failure to Maintain Insurance:** The Contractor's failure to maintain or provide acceptable evidence that it maintains the insurance required in the Specifications shall constitute a material breach of the Contract, upon which the District may immediately withhold payments due to the Contractor, and/or suspend or terminate the Contract. The District, at its sole discretion, may obtain damages from the Contractor resulting from said breach. Alternatively, the District may purchase the insurance required in the Specifications and, without further notice to the Contractor, deduct the premium cost from sums due to the Contractor or pursue reimbursement from the Contractor.

## **INDEMNIFICATION**

To the fullest extent permitted by law, Contractor shall defend, indemnify and hold harmless the District, and its officers, directors, shareholders, members, managers, partners, employees, agents, representatives and sureties ("Indemnified Parties"), from and against any and all claims, losses, suits, actions, demands, awards, judgments, attorneys' fees, expert fees, costs and expenses of every nature which may arise out of, pertain to, or relate to, in whole or in part, Contractor, Contractor's subcontractors and material suppliers, or their employees, agents or representative's performance of the Contract Work, except to the extent caused by the sole or active negligence or willful misconduct of the District, or for claims that do not arise out of the scope of work of Contractor. Contractor's obligation to defend Indemnified Parties shall be immediate upon written notice by the District and Contractor shall, if requested by the District, defend Indemnified Parties using counsel approved in the sole discretion by the District.

## **PAYROLL RECORDS / APPRENTICES / HOURS OF WORK**

**Payroll Records:** The Contractor shall comply with the provisions of Section 1776 of the California Labor Code pertaining to payroll records and will be responsible for compliance by its subcontractor(s).

**Employment of Apprentices:** The Contractor shall comply with the provisions of Section 1777.5 of the California Labor Code relating to the employment of apprentices by the Contractor and its subcontractor(s).

**Hours of Labor:** The Contractor shall comply with Sections 1810 through 1815 of the California Labor Code pertaining to the hours of labor and payment for such. Pursuant to Section 1813 of the California Labor Code, the Contractor and any of its subcontractors, shall forfeit to the District, and the District will withhold from any monies due the Contractor, the amount of twenty-five dollars (\$25) for each worker employed in the execution of the Contract by the Contractor or any of its subcontractor for each calendar day required or permitted to work more than 8 hours in any one calendar day and 40 hours in any one calendar week in violation of the provisions of the Sections 1810 through 1815 of the California Labor Code

## **PROVISIONS REQUIRED BY LAW AND ADDITIONAL RESPONSIBILITIES**

**Compliance with Laws.** Contractor is responsible for all contributions, taxes, deposits and other payments with respect to the wages, salaries, benefits, or other obligations paid or owed by Contractor to Contractor's employees and others who perform work or render services to Contractor. Contractor is responsible for all income, gross receipts, use, and other taxes applicable to materials, equipment, tools, and labor incorporated and used in Contractor's performance of the Contract Work.

Contractor shall comply with all laws, statutes (including, but not limited to, the National Environmental Policy Act, 42 U.S.C. § 4321 *et seq.*; the California Environmental Quality Act, Cal. Public Resources Code § 21000 *et seq.*; the Endangered Species Act, 7 U.S.C. § 136, 16 U.S.C. § 1531 *et seq.*; the California Endangered Species Act, Cal. Fish and Game Code § 2050 *et seq.*; the Clean Water Act, 33 U.S.C. § 1251, *et seq.*; Lake and Streambed Alteration Program, Cal. Fish & Game Code § 1600, *et seq.*; and the National Historic Preservation Act, 16 U.S.C. § 470 *et seq.*; Federal Acquisition Regulations, 48 C.F.R. Chap. 1), regulations (including, but not limited to, those associated with the previously identified statutes), ordinances, building codes, permit conditions, recordkeeping and reporting obligations, mitigation measures and other government requirements of every nature applicable to the Contract Work, and shall obtain and hold all licenses, certifications and other government requirements necessary to perform the Contract Work.

Contractor shall conduct shoring and trench safety operations in accordance with OSHA and the Construction Safety Orders of the State of California, pursuant to the provisions of Section 6707 of California Labor Code. The Contractor shall submit to the District a Site Safety Plan, which shall include details of provisions for worker protection from caving ground.

Contractor shall comply with rules, policies and procedures pertaining to health, safety, substance abuse and general conduct in the workplace established by the California Occupational Safety and Health Administration, and to other rules of law applicable to the Contract Work.

**Superintendence and Cooperation.** Contractor shall have a qualified, experienced, and competent superintendent at the Project at all times during performance of the Contract Work and as otherwise necessary to ensure full performance of Contractor's obligations under the Contract Documents applicable to the Contract Work. Contractor shall provide to District the contact information of all such superintendents, through which such superintendents may be contacted twenty-four hours per day, seven days per week. Contractor is responsible for the superintendence and safety and progress of the Contract Work in conformance with the Contract Documents,

including activities of suppliers and subcontractors. Contractor's superintendent shall have absolute authority in all respects to act for and on behalf of Contractor and to bind Contractor by statements made, agreements reached, actions taken and notices received. Contractor's superintendent shall have the authority and responsibility to execute on behalf of Contractor, promptly and properly, the District's directions relating to the Contract Work.

The Contractor shall place on record with the District, and keep current, the name of the Contractor's superintendent and the phone number at which he/she can be contacted at such times that he/she is not at the work site (such as after working hours and on holidays and weekends) to respond to the District requests to correct safety and other problems that may arise in connection with the Contract Work.

If any person employed by the Contractor, including the Contractor's superintendent, shall fail or refuse to carry out the directions of the District or shall appear to the District to be incompetent or to act in a disorderly, unsafe, or improper manner, that person shall be removed from the work site immediately on the request of the District, and such person shall not again be employed on the Project. Such discharge shall not be the basis for any claim for compensation or damages against the District.

**Protection and Storage.** Contractor shall provide necessary and appropriate protection of the Contract Work, protect the work of others with respect to Contractor's performance of the Contract Work and shall assume all risks of loss, damage, deterioration or destruction of the Contract Work and damage to the work of others caused by Contractor's performance of the Contract Work, including stored materials, by weather, individuals, or other causes until final acceptance by the District. Contractor shall store and protect its materials, equipment, tools and other items as well as those furnished to Contractor by the District or others. Storage areas, workshops, and other areas used or to be used by Contractor, if any, may be designated by the District and no materials, equipment, tools or other items owned or used by Contractor shall be stored except in those areas designated by the District. Notwithstanding such designation by District, it shall be Contractor's responsibility to secure and protect its materials, equipment, tools and other items as well as those furnished to Contractor by the District or others. Contractor shall maintain such areas in an orderly and well-kept manner. Contractor shall coordinate all material, equipment and tool deliveries with the District and Owner prior to delivery to the site. Contractor shall not be entitled to payment for storage either on or off site.

**Site Safety.** Contractor shall comply with all safety laws, rules and regulations applicable to Contractor's performance of the Contract Work including, but not limited to, all federal, state and local rules and regulations promulgated by government agencies.

Contractor shall defend, indemnify and hold harmless the District from and against any and all costs and expenses incurred by the District for fines, penalties and corrective measures resulting from acts or omissions of Contractor, its subcontractors, material suppliers, employees, agents and assigns, resulting from their failure to comply with such safety laws, regulations and rules.

The Contractor shall be solely and completely responsible for the conditions of the work site, including safety of all persons and property during performance of the Contract Work, and any members of the public coming into contact with the work site. This requirement shall apply continuously and not be limited to normal working hours. Contractor shall immediately report to the District any injury to or caused by any of Contractor's employees at the site. A written report shall be made on the date of the incident or accident and submitted by Contractor to the District.

**Labor Relations.** Contractor shall do whatever is necessary in the performance of the Contract Work, or as may be directed by the District, to assure the harmonious labor relations on the Project and to prevent strikes or other labor disputes on the Project. Contractor shall remove from the Project site any subcontractor, material supplier, employee or agent for whom Contractor is responsible whose conduct is considered disruptive or objectionable by the District, or whose

performance is unsatisfactory in the judgment of the District. Contractor agrees that in the event of a work stoppage or other disruption caused in whole or in part by a strike or other labor dispute involving Contractor, its subcontractors, material suppliers, employees, or agents for whom Contractor is responsible, the District shall have the right to terminate Contractor's performance of the Contract Work upon forty eight (48) hours written notice to Contractor.

**Cleanup and Removal and Disposal.** Contractor shall keep the Project site in a safe, clean and neat condition. Contractor shall on a daily basis clean up all trash and debris resulting from Contractor's performance of the Contract Work and shall turn over its work areas in a clean and neat condition so as to permit any succeeding work to be performed without delay and without the need for further cleaning. Contractor shall be responsible for the removal of non-hazardous trash and debris, and shall have responsibility for the discovery, identification, reporting, handling, removal and disposal of all hazardous materials in accordance with applicable federal, state and local laws, regulations, standards and other requirements. Should Contractor fail to keep the project site in a clean and neat condition, fail to clean up all trash and debris resulting from Contractor's performance of the Contract Work, or fail to remove non-hazardous trash and debris or to remove hazardous materials, the District may perform such work through others and charge the cost thereof to Contractor which the District may deduct from any payment due to Contractor

**Qualifications and Inspection.** Contractor represents that it is fully qualified, experienced, and licensed to perform the Contract Work, has had full and adequate opportunity to inspect and conduct any tests deemed necessary by Contractor to perform the Contract Work, and assumes all risks with respect to the Contract Documents and the general and specific conditions involved in performing the Contract Work including, but not limited to, natural and manmade characteristics of the site both above and below ground, site accessibility, site storage, on-site operations, labor rates and availability, weather conditions, and any other condition of any nature which could affect Contractor's cost and performance of the Contract Work.

## **EQUAL EMPLOYMENT OPPORTUNITY (EEO) PROVISIONS**

During the performance of this Contract, the Contractor agrees as follows:

1. The Contractor shall not discriminate against any employee or applicant for employment because of race, color, religion, sex or national origin. The Contractor certifies and agrees that all persons employed by such firm, its affiliates, subsidiaries, or holding companies are and will be treated equally by the firm without regard to or because of race, color, religion, sex or national origin and in compliance with all antidiscrimination laws of the United States of America and the State of California.
2. In all advertisements for labor or other personnel, or requests for employment of any nature, the Contractor shall state that all qualified applicants will receive consideration for employment without regard to race, color, religion, sex or national origin.
3. The Contractor shall deal with its subcontractor without regard to or because of race, color, religion, sex or national origin.
4. The Contractor shall comply with current Federal employment and reporting requirements for publicly funded construction Contracts. Specifically, the Contractor shall make a good faith effort to comply with Federal employment goals for minority and female employment. The Contractor shall report minority and female employment data on the Federal form provided by the District. This form shall be submitted to the Engineer before the start of construction and twice annually by March 1 and September 1 of each year. Each failure to submit this form by due date will result in a Contractor penalty of \$200, which shall be deducted from any monies due the Contractor.

5. The Contractor shall send to each labor union or representative of workers with which it has a collective bargaining agreement or other Contract or understanding, a notice, to be provided by the District, advising the said labor union or worker's representative of the Contractor's commitments under this subsection.
6. The Contractor shall allow the District access to its employment records during regular business hours to verify compliance with these provisions when so requested by the District.
7. The Contractor agrees that if the District finds that any of the above provisions have been violated, the same shall constitute a material breach of the Contract upon which the District may determine to cancel, terminate or suspend the Contract. While the District reserves the right to determine independently that the antidiscrimination provisions of the Contract have been violated, in addition, a determination by the Federal Equal Employment Opportunity Commission or the California Fair Employment and Housing Commission that the Contractor has violated Federal or State antidiscrimination laws shall suffice as a finding by the District that the Contractor has violated the antidiscrimination provisions of the Contract.
8. The Contractor must ensure that facilities provided for employees are provided in such a manner that segregation on the basis of race, color, religion, sex or national origin cannot result. The Contractor may neither require such segregated use by written or oral policies nor tolerate such use by employee custom. The Contractor's obligation extends further to ensuring that its employees are not assigned to perform their services at any location, under the Contractor's control, where the facilities are segregated. This obligation extends to all Contracts containing the equal opportunity clause regardless of the amount of the Contract. The term "facilities," as used in this section, means waiting rooms, work areas, restaurants and other eating areas, time clocks, restrooms, wash rooms, locker rooms, and other storage or dressing areas, parking lots, drinking fountains, recreation or entertainment areas, transportation, and housing provided for employees; Provided, that separate or single-user restrooms and necessary dressing or sleeping areas shall be provided to assure privacy between the sexes. The Contractor agrees to post in conspicuous places, available to employees and applicants for employment, notices setting forth the provisions of nondiscrimination clause. At its option, and in lieu of canceling, terminating or suspending the Contract, the District may impose damages for any violation of the antidiscrimination provisions of this subsection, in the amount of \$200.00 for each violation found and determined. The District and the Contractor specifically agree that the aforesaid amount shall be imposed as liquidated damages, and not as a forfeiture or penalty. It is further specifically agreed that the aforesaid amount is presumed to be the amount of damages sustained by reason of any such violation, because, from the circumstances and the nature of the violation, it is impracticable and extremely difficult to fix actual damages.
9. The Contractor shall include the provisions of the foregoing paragraphs 1 through 8 in every subcontract over \$10,000.00, so that such provisions will be binding upon each subcontractor performing work required by the Contract.

## **PERFORMANCE AND PAYMENT BOND**

The District requires that Contractor furnish to the District, as obligee, a performance and payment bonds for 100% of the Contract value with surety acceptable to the District. The protection and coverage of the bonds furnished by Contractor shall extend at least to the entities protected and types of claims covered by the District's bonds so that no claim can be made against the District's bonds which are not recoverable against Contractor's bonds.

Attachment "A" and "B", Performance and Payment Bonds, respectively, shall be executed and included as attachments to this contract.

## **GUARANTY**

The Contractor guarantees the construction and installation of the work included in this project. Should any of the materials or equipment prove defective or should the work as a whole prove defective, due to faulty workmanship, material furnished or methods of installation, or should the work or any part thereof fail to operate properly as originally intended and in accordance with the Plans and Specifications, due to any of the above causes, all within 12 months from the date of filing the Notice of Acceptance by the Secretary, the Contractor shall reimburse the District upon demand, for its expenses incurred in restoring said work to the condition contemplated in said project, including the cost of any such equipment or materials replaced and the cost of removing and replacing any other work necessary to make such replacement or repairs, or upon demand by the District, to replace any such material and to repair said work completely without cost to the District so that said work will function successfully as originally contemplated.

The District shall have the unqualified option to make any needed replacements or repairs itself or to have such replacements or repairs done by the Contractor. In the event the District elects to have said work performed by the Contractor, the Contractor agrees that the repairs shall be made and such materials as are necessary shall be furnished and installed within a reasonable time after the receipt of demand from the District. If the Contractor shall fail or refuse to comply with his obligations under this guaranty, the District shall be entitled to all cost and expenses, including attorney's fees, reasonably incurred by reason of the said failure or refusal.

## **TERMINATION OF CONTRACT**

**Termination for cause (breach or default):** Should Contractor refuse or fail for any reason to diligently, efficiently, timely, skillfully, safely or cooperatively prosecute the Contract Work; supply sufficient and competent supervision or labor; have sufficient materials and equipment of the proper quality and quantity; promptly correct work considered to be defective; pay its bills; or discharge its obligations related to the Contract Work and/or this Agreement. the District may upon forty eight (48) hours written notice to Contractor (except if Contractor advises the District that it is no longer in business, in which case, no notice is required) terminate Contractor and/or (except in the case of emergencies, in which case, no notice is required) provide such labor, materials, equipment, tools and services and deduct the cost thereof, together with any loss or damage occasioned thereby, from any payment due to Contractor. In addition, the District may use funds otherwise earned by Contractor on the project or other projects to pay Contractor's past due bills and obligations including back charges owed to the District.

If Contractor is terminated, the District may assume control of the Contract Work, take possession of all materials and equipment necessary to continue performance of the Contract Work (including, but not limited to, materials, equipment, tools, supplies or other items located on the project site, in storage off site, in transit to the site, or in the process of being manufactured), prosecute the Contract Work using the District's own forces or those of others, and use funds otherwise owing to Contractor to prosecute and complete the Contract Work. Contractor grants a lien and security interest in all of Contractor's materials, equipment, supplies and contract rights to secure performance and completion of the Contract Work.

Upon termination of Contractor, Contractor shall not be entitled any further payments on the Project until the Contract Work has been completed and accepted by the District, and not until final payment has been received by the District. Contractor shall be liable for all costs and expenses of completing the Contract Work, including all performance costs of any nature plus a reasonable allowance for overhead and profit, and any damages, losses, expenses, attorneys' fees or costs, incurred by the District as a result of the termination of Contractor. If, after final payment to the District, the unpaid balance to Contractor exceeds the performance costs, overhead and profit, and any damages, losses, expenses, attorneys' fees or costs incurred by the District in completing the Contract Work, the District shall pay the difference to Contractor. If, after final payment to the

District, the performance costs, overhead and profit, and any damages, losses, expenses, attorneys' fees or costs incurred by the District in completing the Contract Work exceeds the unpaid balance to Contractor, Contractor shall pay the full amount of difference to the District.

**Termination for convenience:** In addition to the District's right to terminate Contractor for breach or default, the District may terminate Contractor if the District determines that such termination is in the best interest of the Project. Upon such termination, Contractor shall be entitled to the reasonable, actual direct cost of satisfactorily completed Contract Work and materials purchased prior to termination, plus a single mark-up of not more than ten percent (10%) for provable overhead (including job site and home office) and provable profit on satisfactorily completed Contract Work, plus the reasonable out-of-pocket costs of terminating the Contract Work, less any amounts paid by the District, costs incurred by the District and back charges due to the District. Contractor shall not receive any compensation, overhead, or profit on Contract Work not completed or for materials not purchased. Provided, however, that the total sum to which Contractor may be entitled, including all prior payments made to or on behalf of Contractor, shall not exceed the Contract Price.

If, after termination of Contractor, it is determined for any reason that Contractor was not in breach or default, Contractor's sole and exclusively remedy shall only be entitled to the amount due under the Agreement as if termination was for no-fault. Regardless of whether the termination for fault or no-fault, Contractor shall not be entitled to special, consequential or exemplary damages or lost profit on account of termination of Contractor.

The District may, whenever the interests of the District so require, terminate the Contract, in whole or in part, for the convenience of the District. The District will give written notice of the termination to the Contractor specifying the part of the Contract terminated and the date termination becomes effective. The Contractor shall incur no further obligations in connection with the terminated Contract Work, and, on the date set in the notice of termination, the Contractor shall stop Work to the extent specified. The Contractor shall also terminate outstanding orders and subcontracts as they relate to the terminated Contract Work. The Contractor shall settle the liabilities and claims arising out of the termination of subcontracts and orders connected with the terminated Contract Work. The District may direct the Contractor to assign the Contractor's right, title, and interest under the terminated orders or subcontracts to the District. The Contractor must still complete the Contract Work not terminated by the notice of termination and may incur obligations as are necessary to do so. The District may require the Contractor to transfer title and deliver to the District, in the manner and to the extent directed by the District, the fabricated or un-fabricated parts, Contract Work in process, completed Work, supplies, and other material produced or acquired for the Contract Work terminated and other property that, if the Contract had been completed, would be required to be furnished to the District. The Contractor shall, upon direction of the District, protect and preserve property in the possession of the Contractor in which the District has an interest. If the District does not exercise this right, the Contractor shall use its best efforts to sell such supplies and manufacturing materials for the benefit of the District. If the parties are unable to agree on the amount of a termination settlement, the District will pay the Contractor the following amounts:

- a. For Contract Work performed before the effective date of termination, the total (without duplication of any items) of:
  - (i) the cost of work completed in accordance with the Plans and Specifications based on the quantity constructed and the Contract Unit Price or lump sum Bid price of the respective Bid item less prior progress payments, and any applicable Liquidated Damages and any other deductions or withholds to which the District may be entitled to in accordance with applicable law, including the amounts of

outstanding Stop Notices or labor compliance notices to withhold shall be withheld until the Stop Notices or notices to withhold are resolved as provided by law.

- (ii) The District's actual cost of settling and paying terminated subcontracts and orders that are properly chargeable to the terminated portion of the Contract Work; and
- b. The reasonable costs of effectuating the settlement of the Contract Work terminated, including:
  - (i) Accounting, clerical, legal, and other expenses reasonably necessary for the preparation of termination settlement bids and supporting data;
  - (ii) The termination and settlement of subcontracts (excluding the amounts of such settlements); and
  - (iii) Storage, transportation, and other costs incurred, reasonably necessary for the preservation, protection, or disposition of the termination inventory.

**Termination for Improper Consideration:** The District may, by written notice to the Contractor, immediately terminate the right of the Contractor to proceed under the Contract if it is found that consideration, in any form, was offered or given by the Contractor, either directly or through an intermediary, to any District officer, employee or agent with the intent of securing the Contract or securing favorable treatment with respect to the award, amendment or extension of the Contract or the making of any determinations with respect to the Contractor's performance pursuant to the Contract. In the event of such termination, the District shall be entitled to pursue the same remedies against the Contractor as it could pursue in the event of default by the Contractor. The Contractor shall immediately report any attempt by and District officer or employee to solicit such improper consideration. The report shall be made either to the District General Manager, charge with the supervision of the employee The Board of Supervisors. Among other items, such improper consideration may take the form of cash, discounts, service, the provision of travel or entertainment, or tangible gifts.

IN WITNESS WHEREOF, the parties to this Agreement have duly executed it effective on the date set forth above.

**San Bernardino Valley Water Conservation District:**

**CS-NK Constructors:**

Signature: \_\_\_\_\_

Signature: \_\_\_\_\_

Printed Name: Melody McDonald

Printed Name: \_\_\_\_\_

Title: President

Title: \_\_\_\_\_

Date of Execution: \_\_\_\_\_

Date of Execution: \_\_\_\_\_

# BID SCHEDULE

BID FORM: (Refer to Special Provisions for a more detailed description of items included under each of the following items)

The Bidder is required to bid on Items 1 through 8 at a minimum.

ITEM NO.	BASE BID DESCRIPTION	QTY.	UNIT	UNIT PRICE	TOTAL
1	Preliminary & Final Engineering	1	LS		30,000
2	Permitting	1	LS		5,000
3	Clearing and Grubbing	1	LS		8,932
4	Grading / Subgrade Preparation / BMP's (includes over-excavation and re-compaction)	1	LS		19,128
5	Foundation (including footings)	1	LS		29,366
6	Plumbing and Electrical stub outs	1	LS		16,809
7	Pre-Engineered Metal Building w/ Rollup Doors	1	LS		122,162
8	Pre-Engineered Metal Building Insulation	1	LS		10,775
	Total Base Items				242,172
	<b>ADD / DEDUCT ITEMS (NOT REQUIRED)</b>				
1.0	Interior Walls	1	LS		11,343
1.1	Doors and windows (other than rollup Doors) (complete schedule next sheet)	1	LS		2404
1.2	Plumbing (complete schedule next sheet)	1	LS		4075
1.3	Electrical	1	LS		14,255
1.4	Fixtures (complete schedule next sheet)	1	LS		2,789
1.5	Perimeter Walls Interior Lining	1	LS		7,843
1.6	*Items for identified in project plans or specifications. Contractor to submit detailed description with bid				3551
	PERFORMANCE BOND				5633
	Total Add / Deduct Items				51,893

\* Items 1.6 and 1.7 are additional contract items proposed by the bidder

**The Total Bid shall be generated from the above bid items by adding together the total amount for each bid item. The sum of all the bid item amounts shall be the bidder's bid and inserted, both in words and numerically, in this section.**

**Total Bid Items 1 through 8**  
 \$ 294,065 (THIS INCLUDES ENG. PERMITS, & BOND)

**Total Bid Schedule written in words:**  
Two hundred ninety four and sixty five thousand

## BID SUPPLEMENTAL INFORMATION FORM

BID FORM: (Refer to Special Provisions for a more detailed description of items included under each of the following items)

The Bidder is requested to required detailed information on the various items of work to confirm the basis of the bid prices:

Door and Window Schedule			
Location	Quantity and size	Description	Comments
exterior	1-2'-8" x 6'-8" steel door	Commercial grade exterior steel door with hardware	/
exterior	6-3' x 6'-8" steel door	Commercial grade exterior steel door with hardware	3-3'x6'8" TIMELY STEEL DOORS 2 HR FIRE RATED SCHLAGE HARDWARE
exterior	5-3' x 3' windows	Commercial grade, UV resistant, dual pane, tinted, fixed	WELD-WEN ALUMINUM FRAME 3"X4" DUAL GLAZED DOUBLE
exterior	4-3' x 3' windows	Commercial grade, UV resistant, dual pane, tinted, single hung (restroom and chemical storage rooms)	/
interior	1-2'-8" x 6'-8" wood door	Commercial grade interior with door with locking hardware and automatic close (bathroom)	/
interior	1-2'-8" x 6'-8" wood door	Commercial grade interior with door with locking hardware and automatic close (chemical room)	BIRKBECK COMMERCIAL DOOR CLOSER

Fixture and Plumbing Schedule			
Location	Quantity and size	Description	Comments
bathroom	sink	Commercial grade sink with hardware	KOHLER 22 3/4 X 18 DROP IN SINK DELTA HIGH RISE FAUCET
bathroom	toilet	Commercial grade water efficient, dual flush with hardware	KOHLER ELONGATED CHAIR HEIGHT POWER SWISH
bathroom	shower	Commercial grade 4' x 5' x 8" tall fiberglass shower with sliding glass door and water efficient hardware	6x6 WHITE MAINTILE (FLOOR) HOT MOP SHOWER PAN (DRAIN)
bathroom	Water heater	Commercial grade 30 gallon electric water heater	O.A. SMITH ELECTRIC 30 GAL ELEMENT WATER HEATER
garage	Washer / dryer hookups	Commercial grade faucets with drain and vent	BALL VALVE, COPPER PIPE W/DRYER HOOKUPS
garage	Eyewash station	Commercial grade freestanding eyewash fountain with drain	SELLSTORM DECK MOUNTED STATION
exterior	faucets	Faucets along northerly and southerly walls (location TBD)	BALL VALVES-FAUCET MOUNTION 1/2" COPPER PIPE

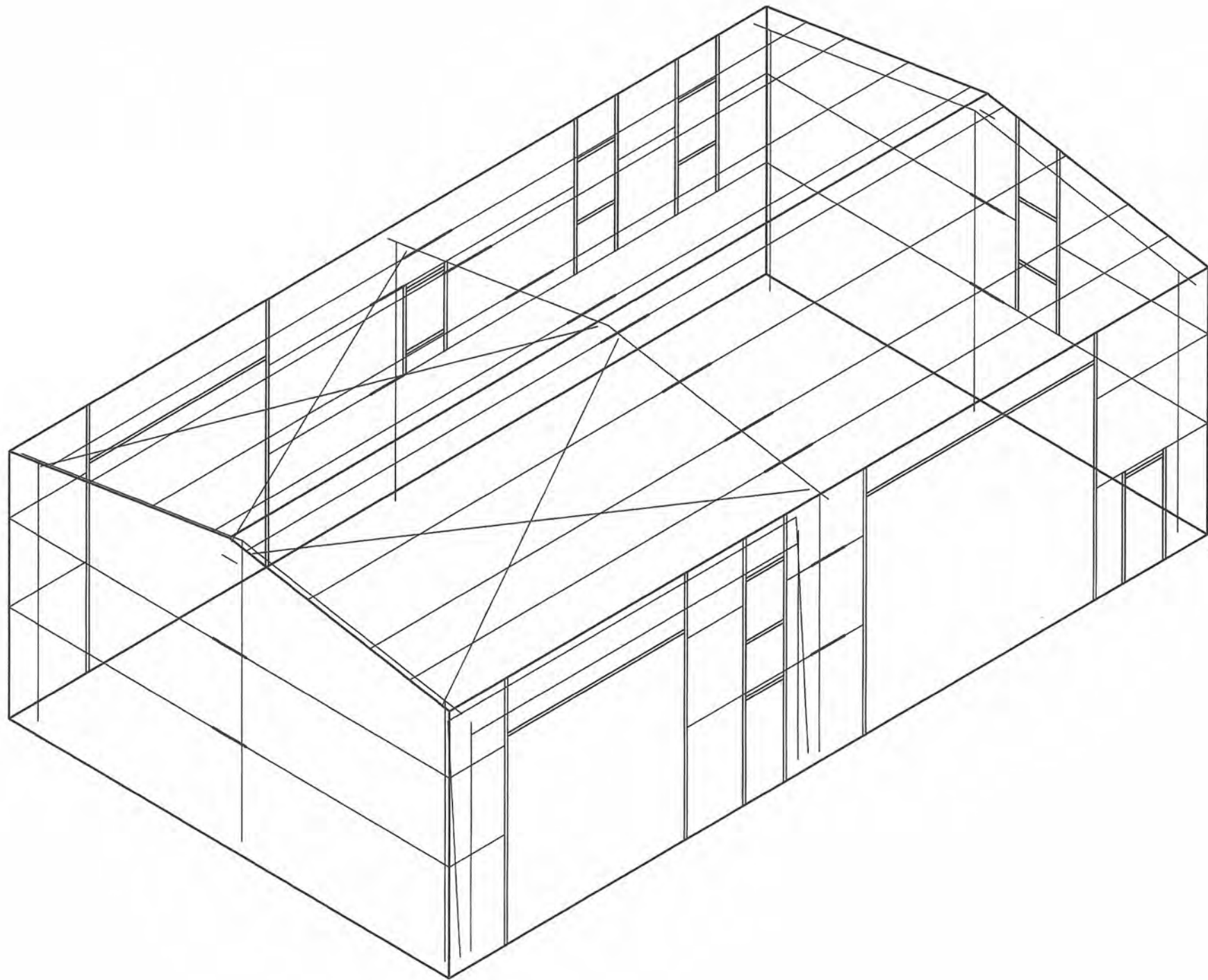

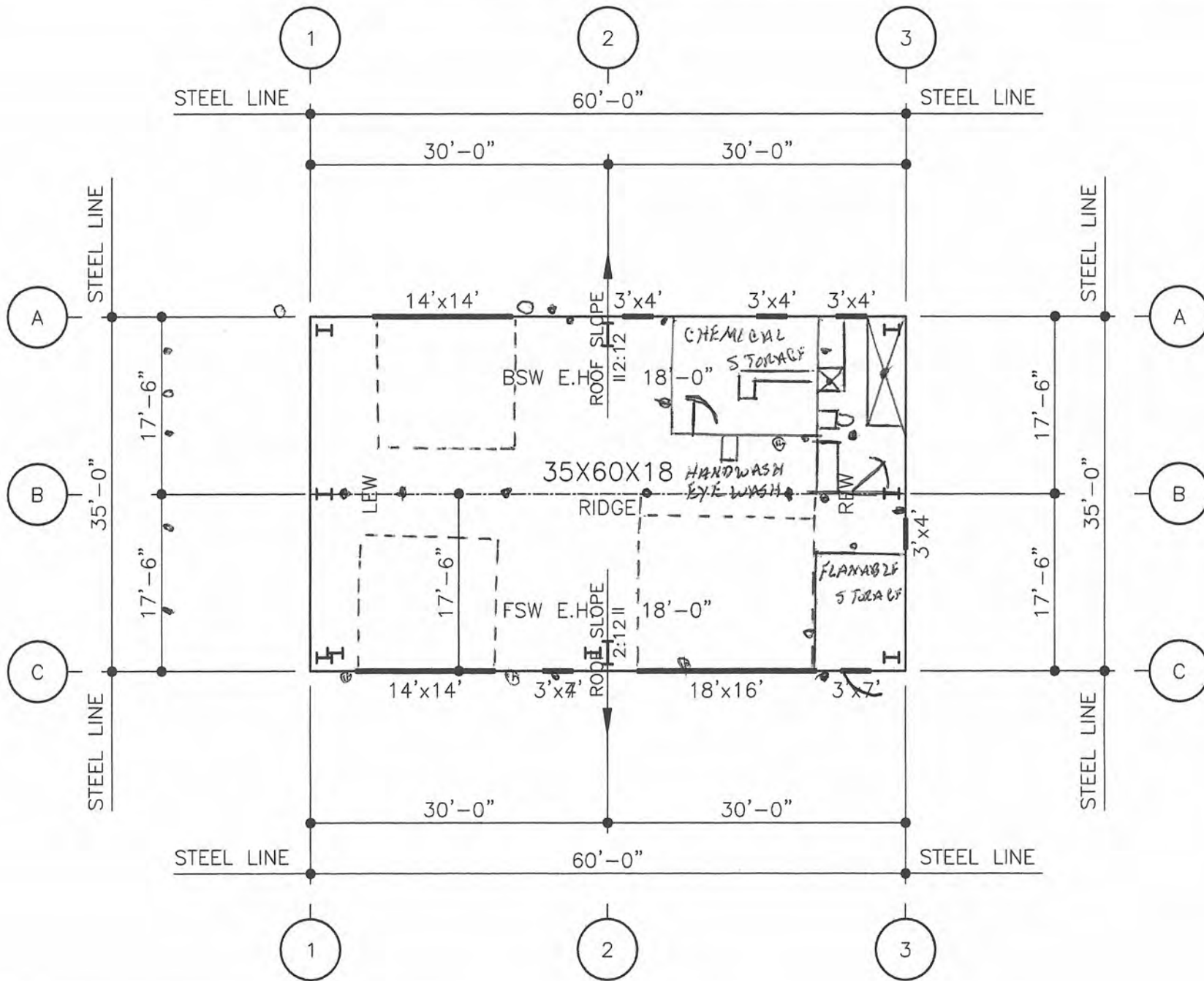

KEY PLAN

35X60X18

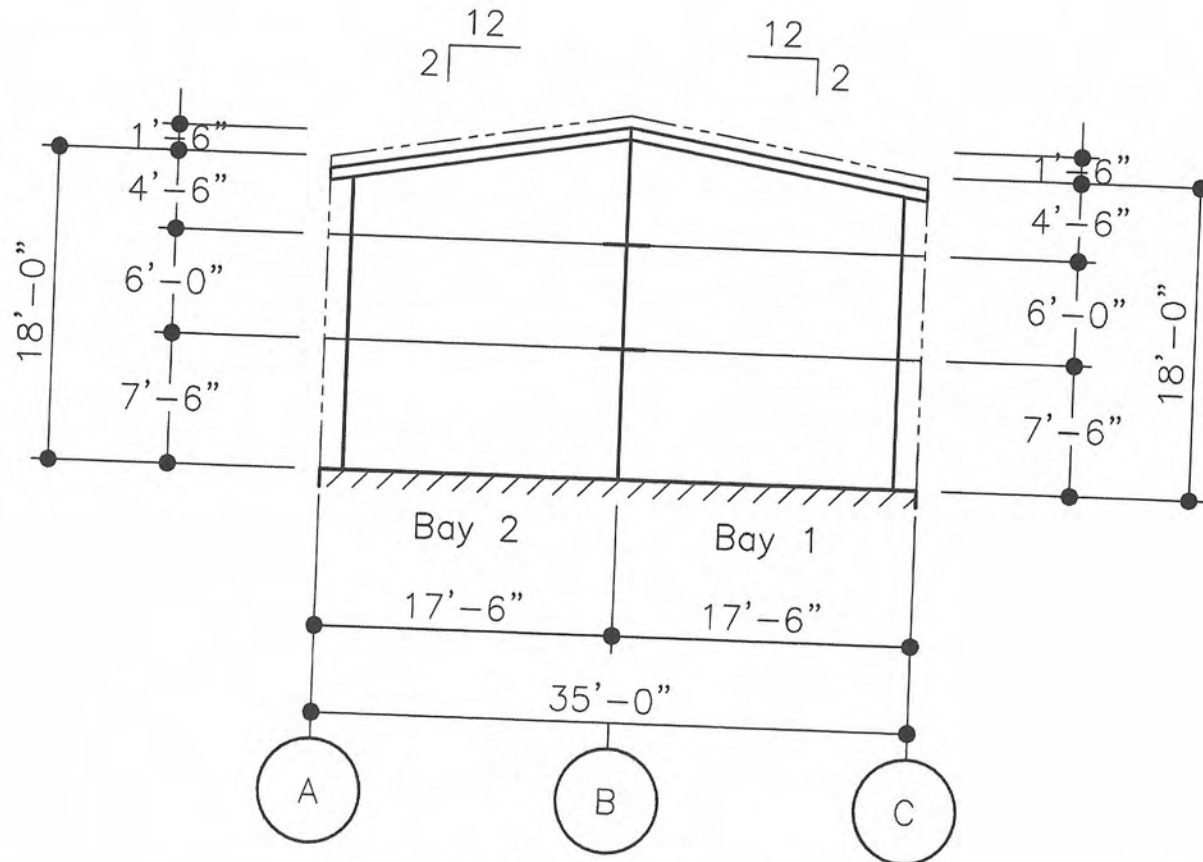

ELEVATION AT LINE 1

KEY PLAN



35X60X18

FRAMED OPENING SCHEDULE

ID	QTY	WIDTH	HEIGHT	SILL HEIGHT	LOCATED
1	1	3'-0"	4'-0"	11'-0"	FACTORY
2	2	3'-0"	7'-0"	0'-0"	FACTORY
3	1	18'-0"	16'-0"	0'-0"	FACTORY
4	1	14'-0"	14'-0"	0'-0"	FACTORY

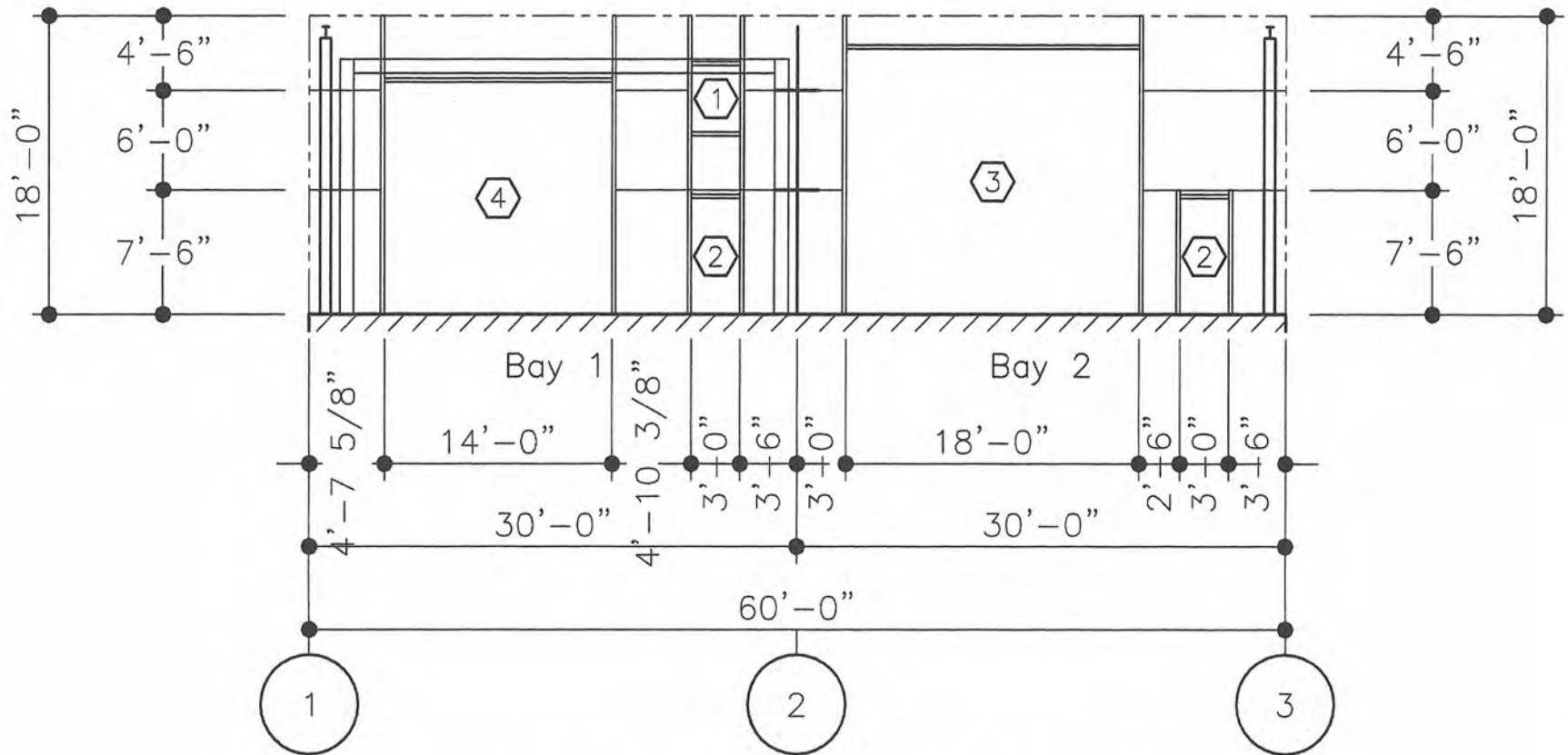

ELEVATION AT LINE C

KEY PLAN



FRAMED OPENING SCHEDULE

ID	QTY	WIDTH	HEIGHT	SILL HEIGHT	LOCATED
1	1	3'-0"	4'-0"	11'-0"	FACTORY

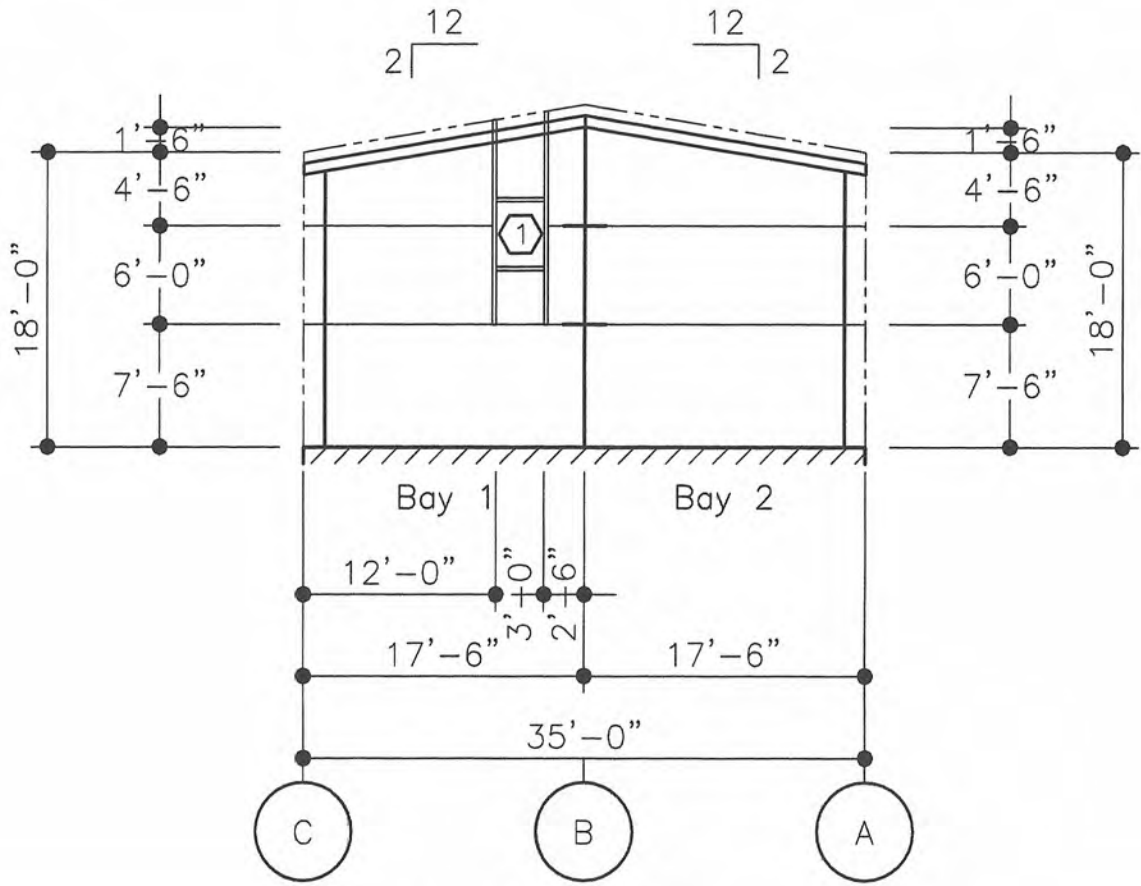

ELEVATION AT LINE 3

KEY PLAN



35X60X18

FRAMED OPENING SCHEDULE

ID	QTY	WIDTH	HEIGHT	SILL HEIGHT	LOCATED
1	2	3'-0"	4'-0"	11'-0"	FACTORY
2	1	3'-0"	4'-0"	9'-0"	FACTORY
3	1	14'-0"	14'-0"	0'-0"	FACTORY

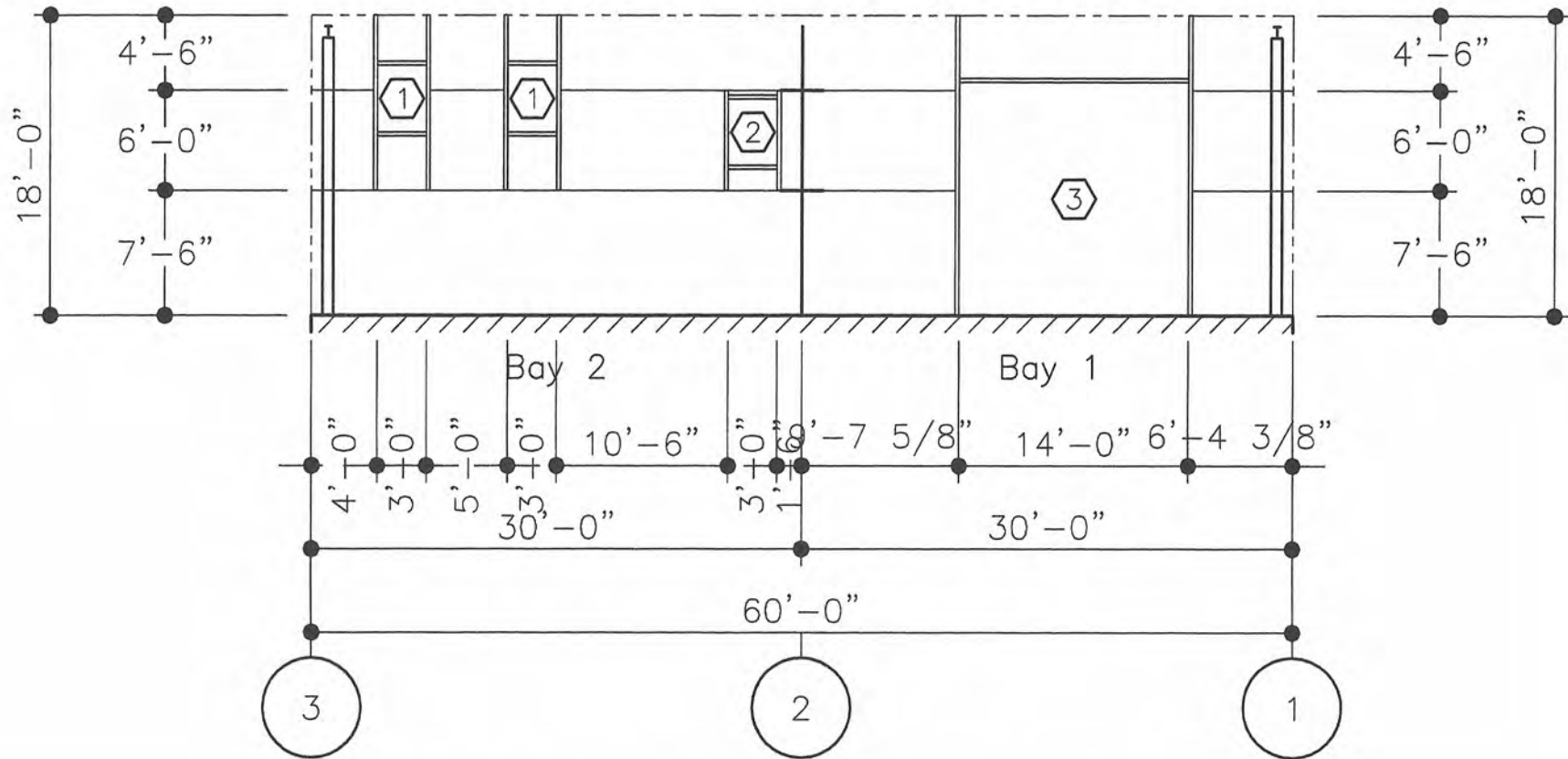

ELEVATION AT LINE A

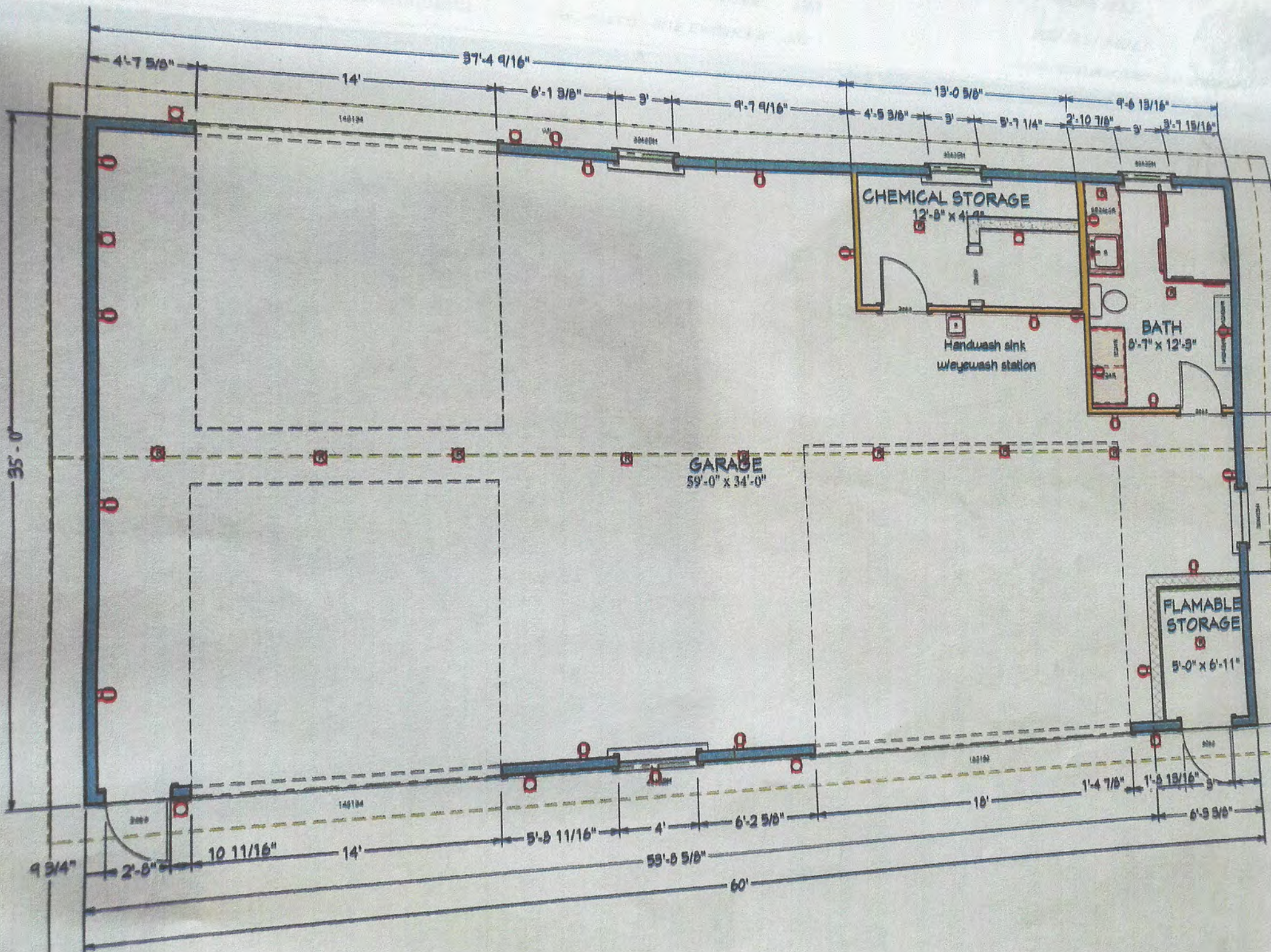

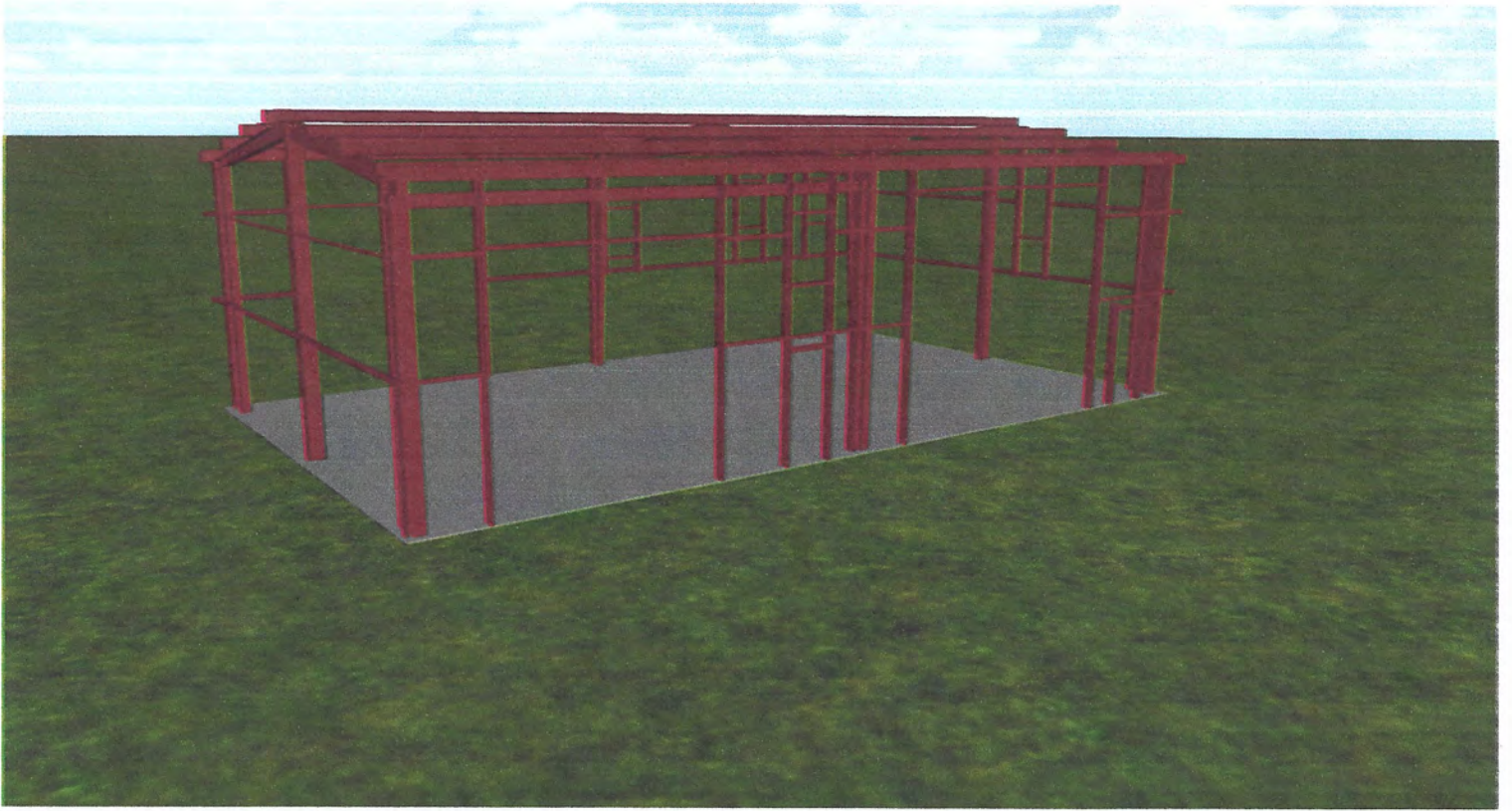

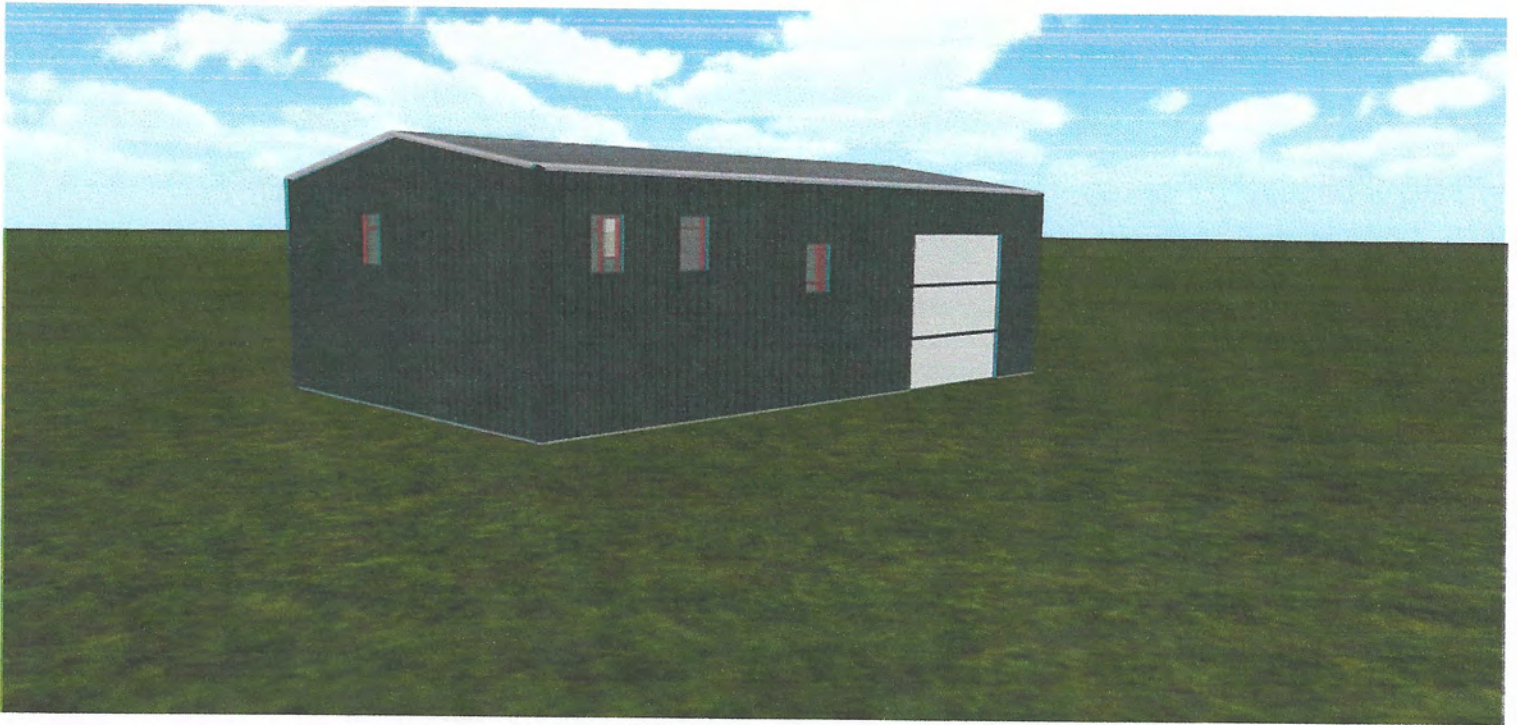







B-837007 Bonded Insured  
 12630 12th Street Yucaipa, CA 92399 office 909 446-1280 cell 951 906-5025

*Quality to the Top, From the Ground Up!*

March 15th, 2022

San Bernardino Valley  
 Water Conservation Dist.  
 2181 Mentone Blvd  
 Mentone, CA 92359

Att: Erwin Fogerson, P E

*Estimate for supplying water to the new structure on the back of the Property.*

Equipment rental, trencher. ----- \$2,675.00  
 Provide material & labor to run 1" PVC pipe w/sleeve from corner  
 of sidewalk and driveway across front of house then downside of  
 house to new structure. ----- \$3,455.85

**\*\* NOTE: if we are unable to tie into existing galvanized pipe and must tap Into meter at street there will be an additional charge of \$1,650.00**

**TOTAL ----- \$6,130.85**

*Estimate to supply electrical power from existing power pole by drive To new building on back of property.*

Equipment rental, trencher, ----- N/C  
 (See above)

Provide material and labor to change out electrical panel on existing power pole.

Bury new power lines underground in 3" electrical power PVC pipe. ----- \$8,344.67

**\*\*NOTE: If we need to run new lines from house to existing power pole there will be an additional charge of \$1,855.00**

One (1) helper for electrician 3-8hour days. Prevailing wage. --- \$1,327.88

**TOTAL ----- \$9,672.55**

**THIS ESTIMATE IS GOOD FOR 30 DAYS DUE TO THE RISING COST OF MATERIAL**

**This estimate does not include any city/county planning fees, architectural fees or building & safety fees.**

Thank you for giving us the opportunity to quote on this part of the project.

Thank you,

Randy Allen

## MENTONE SHOP PRELIMINARY CONSTRUCTION SCHEDULE

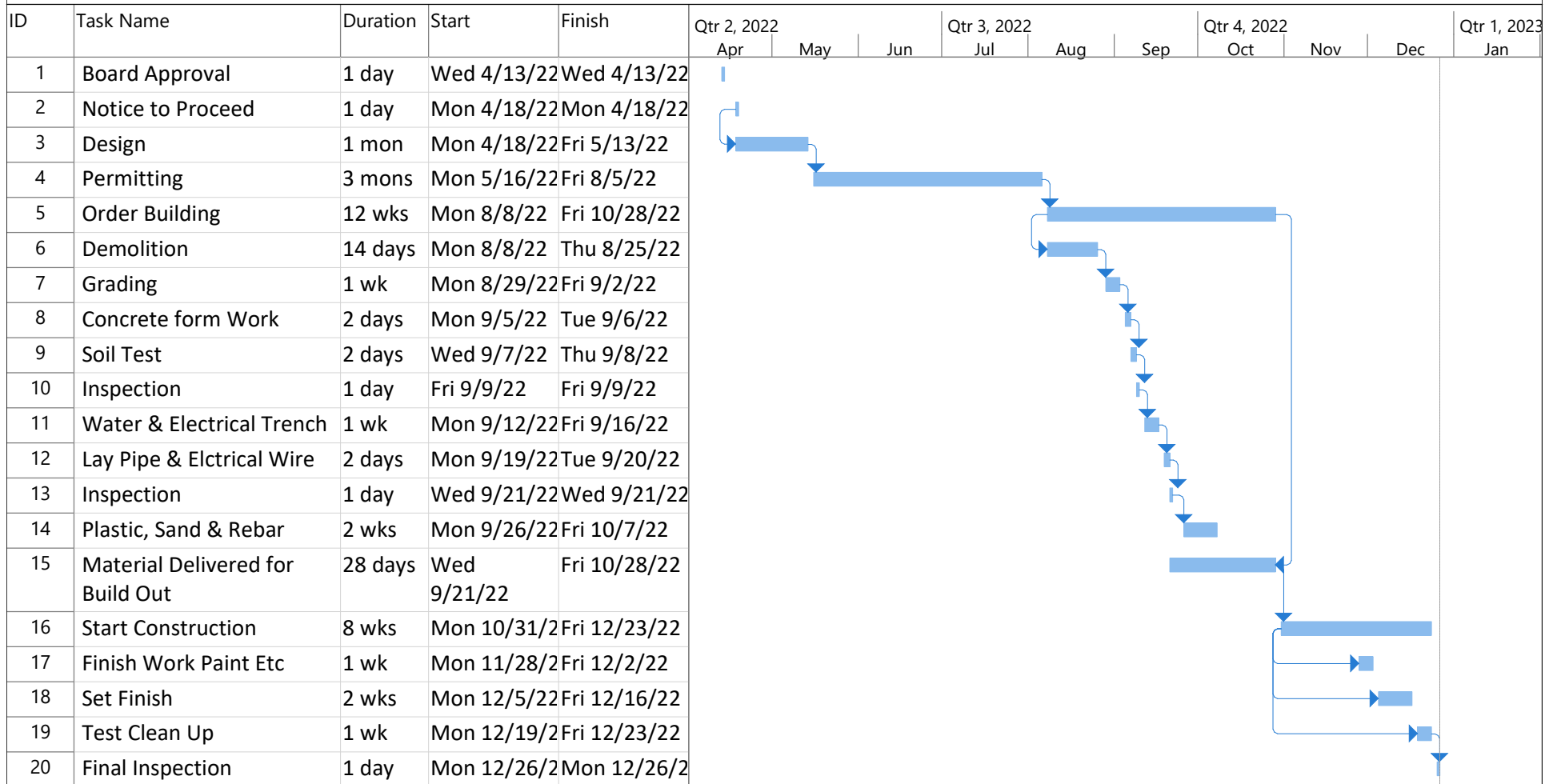

Project: Mentone_Shop_Schedu Date: Mon 3/28/22	Task		Inactive Summary		External Tasks	
	Split		Manual Task		External Milestone	
	Milestone		Duration-only		Deadline	
	Summary		Manual Summary Rollup		Progress	
	Project Summary		Manual Summary		Manual Progress	
	Inactive Task		Start-only			
	Inactive Milestone		Finish-only			



# San Bernardino Valley Water Conservation District

Helping Nature Store Our Water

Memorandum No. 1861

**To:** Board of Directors

**From:** Operations Committee  
Erwin Fogerson, ARTP Engineer  
Katelyn Scholte, Principal Engineer

**Date:** April 13, 2022

**Subject:** Mill Creek Diversion and Debris Management Improvement Project – Sluice Gate Purchase

## **RECOMMENDATION**

Accept the quote from Muller (Hydrogate) and authorize the General Manager to purchase the sluice gates needed for the Mill Creek Diversion and Debris Management Improvement Project in advance of bidding the project for construction.

## **BACKGROUND AND DISCUSSION**

The District is currently proposing to construct improvements to the Mill Creek Diversion gate system to reduce maintenance, environmental impacts, and costs related to debris management. The goal of the Mill Creek Diversion Debris Management Project is to construct a modified diversion system that redirects debris and creek bed sediments back to the Mill Creek channel system, while allowing water to be routed to the existing spreading grounds for groundwater recharge. This improvement will be achieved through reconstruction of the existing facility, components of which were constructed with the original adjacent San Bernardino County Flood Control levee. The levee and flood wall were constructed by the U.S. Army Corps of Engineers (Corps); therefore, the proposed improvements are subject to Section 10 of the Rivers and Harbors Act of 1899, and require authorization from the Secretary of the Army acting through the Corps to issue a 408 permit. The District submitted an application for the 408 permit for this project in 2015. The Corps has requested final signed plans for the project, which indicates that the the 408 permit is currently pending approval of the Waters of the United States 404 Permit.

As part of the review process, the Corps required a design of the sluice gates and frames prior to issuance of the 408 permit. In order to respond to these comments, staff requested quotes from three sluice gate manufacturers: Muller (Hydrogate), Waterman, and Rodney Hunt. Mueller was the only company able to provide both the design and the structural calculations required for the 408 permit. Mueller completed the engineering design of the gates, including structural calculations, for \$21,602 in March of 2021.

1630 W. Redlands Blvd, Suite A  
Redlands, CA 92373  
Phone: 909.793.2503  
Fax: 909.793.0188  
www.sbvwd.org Email: info@sbvwd.org

### **BOARD OF DIRECTORS**

Division 1:  
Richard Corneille

Division 2:  
David E. Raley

Division 3:  
Robert Stewart

Division 4:  
John Longville

Division 5:  
Melody McDonald

### **GENERAL MANAGER**

Daniel B. Cozad

In an effort to expedite construction, staff requested quotes for the construction of the gates and frames from the same three companies. Staff received two responses from 1) Mueller (Hydrogate) for \$114,745, with a credit of \$21,602 for the previously paid engineering and design cost (total cost \$93,143); and 2) Waterman for \$126,221. An additional \$5,000 is expected for shipping, construction coordination, and site inspections for either company. Delivery time is currently estimated at 12-16 weeks for Muller (Hydrogate) and 16-18 weeks for Waterman.

Given that Muller (Hydrogate) completed the original design and structural calculations already accepted by the Corps, the lead time for the construction of the gates is shorter and the quoted price to construct the gates is the lower than other quotes received by the District. Therefore, staff recommends accepting the quote for construction of the gates from Muller (Hydrogate), with additional costs for shipping, construction coordination, and site inspection by Muller (Hydrogate), not exceed a total of \$100,000.

### **FISCAL IMPACT**

Funding for this project is budgeted under GL 7150, Mill Creek Diversion Project CIP, which is funded by the Groundwater Enterprise budget. Fiscal Year 2021/2022 budget for this CIP was \$1,100,000, with a proposed increase in FY23 to the current estimated total project cost of \$1,400,000. Purchase of the sluice gates would result in an expenditure of no more than \$100,000, including \$93,143 for the gates and approximately \$5,000 for shipping, construction coordination, and site inspection costs.

### **POTENTIAL MOTIONS**

1. Find the purchase of the sluice gates in advance of construction bidding is in the best interest of the project, accept the quote from Muller (Hydrogate), and authorize the General Manager to purchase the sluice gates and any incidental costs related to shipping, construction coordination, and site inspection for gate installation by Muller (Hydrogate) for an amount not to exceed a total of \$100,000.
2. Recommend the gates be included in the project construction bid documents where the contractor is required to purchase and provide the gates.

### **ATTACHMENTS OR MATERIALS**









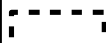

1. Mill Creek Diversion Project Overview Map
2. Mueller – Hydrogate Quote
3. Waterman Quote

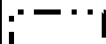
# Proposed Condition- Mill Creek Diversion Intake Structure Improvement Project

Coordinate System: StatePlane California V FIPS 0405 Feet 2007  
 Projection: Lambert Conformal Conic  
 Datum: North American 1983  
 Scale: 1:24,000  
 Source: SBVWCD GIS  
 GIS Contact: Katelyn Scholte  
 April 4, 2022



**Legend**

<b>Limits of Impact</b>	<b>Project Elements</b>	 Reinforced Concrete Wall
 Limit of Grading	 Access Road (Driveable Grouted Rock)	 Sediment Bypass Berm
 Limit of Work	 Channel Berm	 Debris Diverter Wall
	 Hardened Debris Return	 Cat Walk
	 UngROUTED Rock	 Trash Rack
	 Intake Structure Approach Channel	
	 Sediment Bypass Channel	

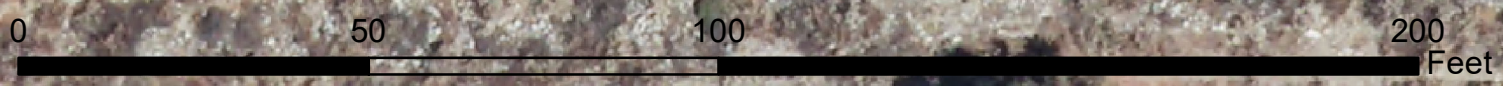
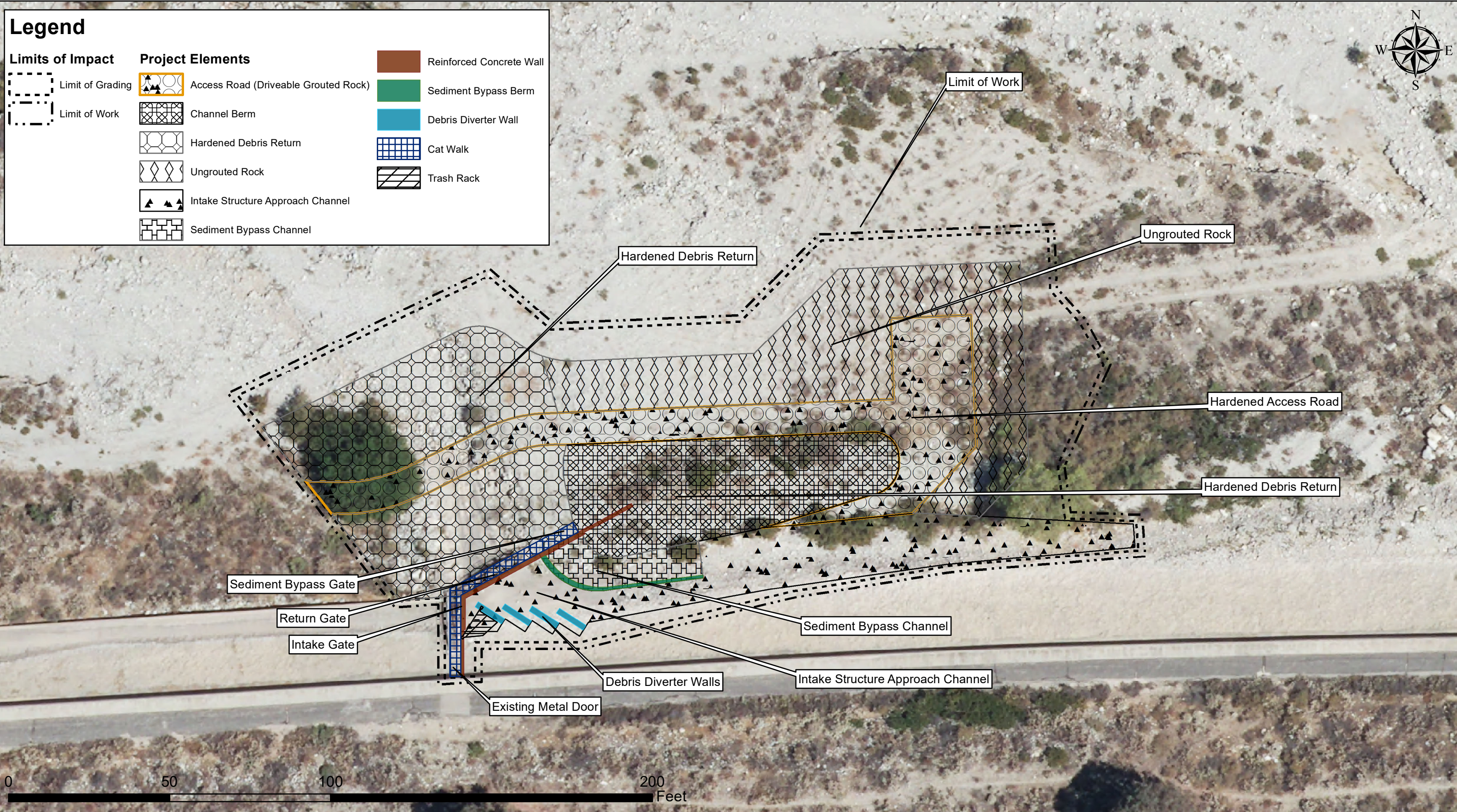

# QUOTE # 2102009 R1

**Date: March 9, 2022**

**Project Name: Mill Creek - CA**

**Bid Date: N/A**

**Representative: Southwest Valve / Kelly Brians / 714-832-1090**

We are pleased to offer for your consideration the following equipment for this project.

Quantities and descriptions listed in this quotation were based on the following:  
Emailed information only. One drawing. Specification section 206-7 Slide Gates only.

Please note these prices are based on receiving the entire order. Adjustments to item quantities or specifications may alter the pricing.

- Prices quoted are firm for acceptance within 30 days of the bid date and apply to this quotation only, subject to attached Terms & Conditions. Prices do not include sales or use tax. If this proposal is not accepted within 30 days after bid, Hydro Gate reserves the right to re-quote and price escalation may be necessary.

The equipment we have quoted meets or exceeds the specifications with the following clarifications:

**NOTE: We have received no addendums for this project.**

1. If awarded to Hydro Gate, we will need to be supplied with a full set of plans and specifications.
2. Prices do not include third party inspection services of gates and equipment unless specifically required by specifications that supplier (Hydro Gate) be responsible for cost of these inspections.
3. Hydro Gate will provide digital copies of all relevant Operation and Maintenance manuals. Contact Hydro Gate should custom manuals be required.
4. Please note these prices are based on receiving the entire order. Adjustments to item quantities or specifications may alter the pricing.
5. Prices do not include taxes.
6. Non-machined, submerged ferrous surfaces to be blast cleaned and painted with 2 shop coats of manufacturer's standard epoxy paint.

7. This quotation reflects our policy of sourcing raw materials in the most cost effective manner. Any requirement for specific U.S content shall require a revised quotation.
8. Prices do not include installation of gates and equipment or lubricants for stems, gear units and bearings.
9. Mastic, grout, gaskets and epoxy capsules for anchors not by Hydro Gate.
10. Upon placing an order with Hydro Gate, buyer must ensure that the approval of equipment be provided to Hydro Gate within 30 days of receiving submittals. Failure to do so may result in an increase of price in relation to market fluctuation of raw material costs.
11. Please address all purchase orders to Henry Pratt Company, LLC 12000 East 47th Ave., Suite 200, Denver, CO 80239.
12. Hydro Gate Standard Terms and Conditions of Sale apply to this quotation and can be found at [www.hydrogate.com/support](http://www.hydrogate.com/support).
13. Field service not included. If field service is needed, a charge of \$1,500.00 will be made for each trip, plus \$1,250.00 for each day including any holidays, weekends or other layovers made at the convenience of the contractor or engineer.
14. R1 created to update pricing and reduce per submittal cost from order # 2929922.

**Quotation Number: 2102009 R1**

**Item Number :** 01  
**Qty/Size :** 1 – 60” x 60”  
**Gate :** Fabricated Slide Gate Model HG561 with type 304 stainless steel frame and slide, stainless steel fasteners. Self-contained frame, polymer bearing bars in guide grooves and UHMW seals.  
**Mounting :** Stainless steel anchor bolts.  
**Lift :** Yoke mounted geared crank lift with Type 304 Stainless Steel stem and plastic stem cover with mylar position indicator.  
**Frame Height:** 7.7’ (from centerline)  
**Gate Ship :** 10-12 weeks after drawing and credit approval.  
**Price Each :** \$ 14,924.00

**Item Number :** 02  
**Qty/Size :** 1 – 60” x 60”  
**Gate :** Fabricated Slide Gate Model HG561 with type 304 stainless steel frame and slide, stainless steel fasteners. Self-contained frame, polymer bearing bars in guide grooves and UHMW seals.  
**Mounting :** Stainless steel anchor bolts.  
**Lift :** Yoke mounted geared crank lift with Type 304 Stainless Steel stem and plastic stem cover with mylar position indicator.  
**Frame Height:** 9.5’ (from centerline)  
**Gate Ship :** 10-12 weeks after drawing and credit approval.  
**Price Each :** \$ 15,151.00

**Item Number :** 03  
**Qty/Size :** 1 – 204” x 60”  
**Gate :** Fabricated Slide Gate Model HG561 with type 304 stainless steel frame and slide, stainless steel fasteners. Self-contained frame, polymer bearing bars in guide grooves and UHMW seals.  
**Mounting :** Stainless steel anchor bolts.  
**Lift :** Yoke mounted geared crank lift. Tandem type 304 stainless steel stems and plastic stem cover with mylar position indicator.  
**Frame Height:** 7.7’ (from centerline)  
**Gate Ship :** 10-12 weeks after drawing and credit approval.  
**Price Each :** \$ 84,670.00

**Total price for items listed above: \$ 114,745.00**

**Total price for items listed above, with \$ 21,602 Credit for Submittals: \$ 93,143.00**

- Submittals entered as Order 2929922.

**NOTE: Item 04 was purchased on Order # 2929922**

**Item Number** : 04  
**Qty/Size** : 1 Lot to include...  
**Misc.** : Design calculations for Items 1 – 3.  
**Calculations** : 3-5 weeks after receipt of PO.  
**Lot Price** : \$ 21,602.00

**NOTE:** If Item 04 is ordered and then the gates are ordered after calculation approval, the cost of Item 04 will be credited to the price of the gates (Items 1 – 3)

The delivery lead times are based on stock inventory at the time of quotation. Stock quantities and quoted delivery times must be re-evaluated and verified at time of order and/or time of release to manufacturing.

Please see notes 1 through 14 in this quotation.

**Quotation No.: 2102009 R1**

**FREIGHT:**

F.O.B. shipping point, full freight allowed. Seller will pay freight charges for standard shipments. Additional freight cost incurred to comply with buyer's special requirements will be added to the invoice.

**FIELD SERVICE:**

Hydro Gate will make every effort to provide a representative to meet your schedule, but due to conflicting requirements a request should be made no later than fourteen (14) days before a representative is required. Where previous commitments have been made, some flexibility in your schedule should be anticipated. All field service trips will require a written confirmation prior to arriving at the site.

**DRAWINGS:**

Submittal drawing lead time is 3 to 5 weeks after receipt of your written purchase order.

Thank you for your interest in our product. If any questions arise regarding this quotation, please contact Hydro Gate.



**David Lowe**

Hydro Gate® Specialty Products Engineer

12000 E. 47th Avenue - Suite 200 Denver, CO 80239

office: 303.253.6949 | [muellerwp.com](http://muellerwp.com)



A DIVISION OF MCWANE PLANT AND INDUSTRIAL

QUOTATION NO: WQ22-A-37507

DATE: Mar 21, 2022

25500 ROAD 204 EXETER, CA 93221-0458

PAGE 1 OF 5

**To:** San Bernardino Valley Water Conservation District  
**ATTN:** Erwin Fogerson PE  
**PH:**C: 909-239-2052  
**Emails:** [efogerson@sbywcd.org](mailto:efogerson@sbywcd.org)

Subject to the terms and conditions attached, or as modified in writing, we are pleased to offer this quotation.

STAINLESS STEEL SLIDE GATES  
MILL CREEK DIVERSION  
SAN BERNARDINO VALLEY WCD

PLEASE REFER TO ABOVE QUOTATION NUMBER ON ALL CORRESPONDENCE.

McWane Plant & Industrial LLC d/b/a Waterman Valve

**Juan Rivera.**

Juan Rivera.

Engineered Products Division

Phone: 714-892-4200

Quote Date: Mar 16, 2022 (MR)



QUOTATION NO: WQ22-A-37507

DATE: Mar 21, 2022

Page 2 of 5

Item	Description	Quantity	Price	Total
1	60 x 60 Inch Stainless Steel Slide Gate Frame F Std Flangeback Stainless Steel Type 304L Gate Mounted on Grout Pad (Grout by Others) Frame is self contained Frame Seal Neoprene Cover Stainless Steel Type 304L Gate Seats UHMW Top of Wall to Invert = 7.2 Ft Lift & Stem based on Operating heads 4.7 ft. Seating and 4.7 ft. Unseating Stem Stainless Steel Type 304 Geared Lift Lift mounted to Yoke Stem Cover Clear Plastic Mounting hardware Stainless Steel Type 316 Submittal Drawings	1 @	\$ 17,257.00	\$ 17,257.00
2	60 x 60 Inch Stainless Steel Slide Gate Frame F Std Flangeback Stainless Steel Type 304L Gate Mounted on Grout Pad (Grout by Others) Frame is self contained Frame Seal Neoprene Cover Stainless Steel Type 304L Gate Seats UHMW Top of Wall to Invert = 9 Ft Lift & Stem based on Operating heads 6.5 ft. Seating and 6.5 ft. Unseating Stem Stainless Steel Type 304 Geared Lift Lift mounted to Yoke Stem Cover Clear Plastic Mounting hardware Stainless Steel Type 316 Submittal Drawings	1 @	\$ 17,752.00	\$ 17,752.00



QUOTATION NO: WQ22-A-37507

DATE: Mar 21, 2022

Page 3 of 5

Item	Description	Quantity	Price	Total
3	204 x 60 Inch Stainless Steel Slide Gate Frame F Std Flangeback Stainless Steel Type 304L Gate Mounted on Grout Pad (Grout by Others) Frame is self contained Frame Seal Neoprene Cover Stainless Steel Type 304L Gate Seats UHMW Top of Wall to Invert = 7.2 Ft Lift & Stem based on Operating heads 4.7 ft. Seating and 4.7 ft. Unseating Stems Stainless Steel Type 304 Tandem Geared Lifts Lifts mounted to Yoke Stem Covers Clear Plastic Mounting hardware Stainless Steel Type 316 Submittal Drawings	1 @	\$ 88,199.00	\$ 88,199.00
			Sub Total	\$ 123,208.00
Freight	Freight estimate is valid at the time of quote. Customer will be responsible for actual freight costs at the time of shipment. Freight for an estimated (1) shipment. Any partial shipments at the buyer's request will be pre-paid and add. The delivery term is EXW (Incoterms 2020) Sellers Dock.		Estimated Freight	\$3,013.00
			Grand Total	\$ 126,221.00

**Notes:**

- 1 Specifications were not provided. Please verify all sizes, quantities, materials, and product application which are listed in this quotation. If the customer finds that Waterman Valve has not proposed the correct information, contact your Waterman representative for proposal review.



QUOTATION NO: WQ22-A-37507

DATE: Mar 21, 2022

Page 4 of 5

Item	Description	Quantity	Price	Total
------	-------------	----------	-------	-------

Terms & Conditions

The MCWANE PLANT & INDUSTRIAL, LLC STANDARD Terms and Conditions of Sale, found at [www.watermanusa.com](http://www.watermanusa.com) under the Terms and Conditions tab (“Online Terms and Conditions”), including but not limited to all warranties, disclaimers of implied warranties and limitations on liability, are incorporated herein by this reference. Each party agrees that all sales of Goods by Waterman Valve, a division of McWane Plant & Industrial, LLC, (“Seller”) to Buyer are governed by the Online Terms and Conditions which supersede any other or inconsistent terms of Buyer or Seller. Each party agrees that the Online Terms and Conditions will also govern all sales of Goods to Buyer by any Waterman Valve affiliate or parent, in which case such affiliate or parent will be the “Seller” under this Agreement (unless otherwise agreed in writing by such affiliate or parent). Buyer acknowledges that the Online Terms and Conditions are subject to change from time to time and the parties agree that each sale of Goods will be governed by the version of the Online Terms and Conditions available at the time of Seller’s acceptance of an order for such Goods.

The prices offered are EXW (Incoterms® 2020) seller dock. Freight is prepaid when the freight option in this quote is purchased with equipment. This quotation is firm for 4 weeks from the date of this quotation, except as otherwise provided in this quotation. Freight quoted is an estimate only based on freight prices at the time of quotation. Freight charged will be actual freight at the time of shipping. The price quoted in this quotation for equipment is based on material prices at the time of this quotation. Price quoted in this quotation for equipment will be honored for equipment released for shipment within twelve (12) months from the date of this quotation. Waterman Valve reserves the right to increase pricing for equipment released for shipment more than 12 months from the date of this quotation if material prices increase.

**TAXES:** If applicable, are NOT included in this quotation.

**TERMS:** Net 30 days after delivery subject to credit approval, or cash in advance

**SUBMITTALS:** Estimated best time for submittals is 2-4 **Weeks** after receipt of order. Drawings for submittals will be scheduled upon receipt of the purchase order and based on current engineering schedules at that time. Waterman Valve requests the return of submittals within 6 weeks after submission by Waterman Valve of submittals. If customer does not return approved submittals to Waterman Valve within that time, Waterman Valve reserves the right to request a price increase for any increases in material costs or other production costs due to such delay.

**SHIPMENTS:** Shipments can be made in an estimated 16 - 18 **Weeks** after receipt of order and approval of any submittal drawings required, subject to unavoidable delays as noted on the Online Terms.



**GENERAL NOTES:**

1. Quotation reflects **no addenda**. Should additional addenda be issued, please check for possible variations.
2. Spare parts are not required.
3. Cost of any inspection or material certifications performed by non-Waterman personnel, if required are not included and are to be paid by purchaser or by issuance of a separate purchase order.
4. A suitable alternate paint system will be used where Governmental restrictions prohibit application of specified system.

**FIELD SERVICE RATES**

Title	Per Hour/Per Person (Normal Work Day)	Weekend /Holiday
Engineer	\$300.00	\$600.00
Factory Specialist	\$250.00	\$500.00
*Note: Minimum charge of 4 hours @ 100 mile radius, 8 hour minimum charge over 100 mile radius from Exeter California.		

1. Hours are “portal to portal” thus include travel time. (Excludes off job site meal and rest periods.)
2. Expenses are billable at cost.
3. Travel expenses include: transportation, communications, food, lodging, and reasonable incident expenses.
4. Parts are billable at prevailing list price, except warranty items.
5. Equipment rentals and other locally procured goods and services are billed at cost.

THE MCWANE PLANT & INDUSTRIAL, LLC STANDARD TERMS AND CONDITIONS OF SALE, FOUND AT [WWW.WATERMANUSA.COM](http://WWW.WATERMANUSA.COM) UNDER THE TERMS AND CONDITIONS TAB (“ONLINE TERMS AND CONDITIONS”), INCLUDING BUT NOT LIMITED TO ALL WARRANTIES, DISCLAIMERS OF IMPLIED WARRANTIES AND LIMITATIONS ON LIABILITY, ARE INCORPORATED HEREIN BY THIS REFERENCE. EACH PARTY AGREES THAT ALL SALES OF GOODS BY WATERMAN VALVE, A DIVISION OF MCWANE PLANT & INDUSTRIAL, LLC, (“SELLER”) TO BUYER ARE GOVERNED BY THE ONLINE TERMS AND CONDITIONS WHICH SUPERSEDE ANY OTHER OR INCONSISTENT TERMS OF BUYER OR SELLER. EACH PARTY AGREES THAT THE ONLINE TERMS AND CONDITIONS WILL ALSO GOVERN ALL SALES OF GOODS TO BUYER BY ANY WATERMAN VALVE AFFILIATE OR PARENT, IN WHICH CASE SUCH AFFILIATE OR PARENT WILL BE THE “SELLER” UNDER THIS AGREEMENT (UNLESS OTHERWISE AGREED IN WRITING BY SUCH AFFILIATE OR PARENT). BUYER ACKNOWLEDGES THAT THE ONLINE TERMS AND CONDITIONS ARE SUBJECT TO CHANGE FROM TIME TO TIME AND THE PARTIES AGREE THAT EACH SALE OF GOODS WILL BE GOVERNED BY THE VERSION OF THE ONLINE TERMS AND CONDITIONS AVAILABLE AT THE TIME OF SELLER’S ACCEPTANCE OF AN ORDER FOR SUCH GOODS.

Terms of Sale reviewed and accepted by: \_\_\_\_\_ Date: \_\_\_\_\_  
 (Signature of Buyer's Representative)

Name: (please type or print) \_\_\_\_\_ Title: \_\_\_\_\_

Quote Number: WQ22-A-37507  
 Quoted: Mar 16, 2022



**San Bernardino Valley  
Water Conservation District**  
Helping Nature Store Our Water

Memorandum No. 1862

**To: Board of Directors**  
**From: David B. Cosgrove, General Counsel**  
**Date: April 9, 2022**  
**Subject: General Manager Discretionary Bonus**

---

**RECOMMENDATION**

Consider and provide staff guidance on the Board’s determination of a discretionary performance bonus for the General Manager.

**BACKGROUND AND DISCUSSION**

The “AGREEMENT FOR EMPLOYMENT OF GENERAL MANAGER” with Mr. Cozad, dated July 1, 2021, allows for the award of a discretionary performance bonus, in the amount of up to five percent (5%) of existing base salary, for achievement of District objectives. Specifically, the operative language of the contract is as follows:

“Employee shall be eligible for a merit performance bonus, in addition to the salary provided for herein, in an amount up to five percent (5%) of Employee’s base salary. Such merit performance bonus may be awarded by the Board of Directors in its sole and absolute discretion, in any amount up to five percent (5%) of Employee’s base salary, or no amount at all, or any figure in between. The merit performance bonus shall be determined based upon Employee’s perceived progress in successfully implementing the District Strategic Plan, Policies, and Priorities...”

Mr. Cozad’s current base salary is two hundred ninety-five thousand three hundred seventy-two dollars (\$295,372.00). Five percent of that amount is fourteen thousand seven hundred sixty-nine dollars (\$14,769.00). That figure is the top end of the bonus eligibility.

As provided in the contract, the Board may award any amount of bonus based on Mr. Cozad’s progress over the past year in accomplishing the Board’s directions, as spelled out in the District Strategic Plan and its implementing policies.

1630 W. Redlands Blvd, Suite A  
Redlands, CA 92373  
Phone: 909.793.2503  
Fax: 909.793.0188  
www.sbvxcd.org Email: info@sbvxcd.org

**BOARD OF DIRECTORS**

Division 1:  
Richard Corneille  
Division 2:  
David E. Raley

Division 3:  
Robert Stewart

Division 4:  
John Longville

Division 5:  
Melody McDonald

**GENERAL MANAGER**

Daniel B. Cozad

**FISCAL IMPACT**

From zero to fourteen thousand seven hundred sixty-nine dollars (\$14,769.00).

**POTENTIAL MOTIONS**

1. Approve a discretionary bonus for the General Manager in an amount deemed appropriate by the Board.
2. Determine not to award a discretionary bonus to the General Manager this year.
3. Provide other direction to Staff.
4. Table the item to a future meeting for consideration (noting the General Manager's retirement date of May 18, 2022).



# San Bernardino Valley Water Conservation District

Helping Nature Store Our Water

Memorandum No. 1863

**To:** Board of Directors  
**From:** Betsy Miller, Assistant General Manager  
**Date:** April 13, 2022  
**Subject:** 2022 Revised Board Meeting Calendar

---

## **RECOMMENDATION**

Review, revise and consider approval of the proposed revisions to the District Board Meeting Calendar for calendar year 2022.

## **BACKGROUND AND DISCUSSION**

The Board approved the Board Calendar for 2022 on November 10, 2021, with revisions per Director requests approved on February 9, 2022. The May meeting, as approved in February, is scheduled for May 11 at 1:30 PM. In order to facilitate the up-coming 90<sup>th</sup> Anniversary celebration, also scheduled for May 11, staff recommends moving the meeting to 9:00 AM from 1:30 PM.

In addition, the Operations Committee has moved its remaining quarterly meetings to July 5 from July 12, and to October 4 from October 3.

## **FISCAL IMPACTS AND BENEFITS**

There is no fiscal impact related to setting meetings.

## **ATTACHMENTS**

Revised Board Calendar for 2022

1630 W. Redlands Blvd, Suite A  
Redlands, CA 92373  
Phone: 909.793.2503  
Fax: 909.793.0188  
www.sbvwd.org Email: info@sbvwd.org

### **BOARD OF DIRECTORS**

Division 1:  
Richard Corneille

Division 2:  
David E. Raley

Division 3:  
Robert Stewart

Division 4:  
John Longville

Division 5:  
Melody McDonald

### **GENERAL MANAGER**

Daniel B. Cozad



## 2022 Board Calendar - San Bernardino Valley Water Conservation District

JANUARY						
S	M	T	W	Th	F	S
						1
2	3	4	5	6	7	8
9	10	11	12	13	14	15
16	17	18	19	20	21	22
23	24	25	26	27	28	29
30	31					

Jan. 12 Board Meeting  
Jan. 26 2<sup>nd</sup> Qtr. Finance & Admin Mtg.

JULY						
S	M	T	W	Th	F	S
					1	2
3	4	5	6	7	8	9
10	11	12	13	14	15	16
17	18	19	20	21	22	23
24	25	26	27	28	29	30
31						

Jul. 5 Operations Committee Mtg.  
Jul. 13 Board Meeting  
Jul. 27 4<sup>th</sup> Qtr. Finance & Admin Mtg.

FEBRUARY						
S	M	T	W	Th	F	S
		1	2	3	4	5
6	7	8	9	10	11	12
13	14	15	16	17	18	19
20	21	22	23	24	25	26
27	28					

Feb. 9 Board Meeting

AUGUST						
S	M	T	W	Th	F	S
	1	2	3	4	5	6
7	8	9	10	11	12	13
14	15	16	17	18	19	20
21	22	23	24	25	26	27
28	29	30	31			

Aug. 10 Board Meeting

MARCH						
S	M	T	W	Th	F	S
		1	2	3	4	5
6	7	8	9	10	11	12
13	14	15	16	17	18	19
20	21	22	23	24	25	26
27	28	29	30	31		

Mar. 9 Board Meeting  
Engineering Investigation Report Presentation  
Mar. 23 3<sup>rd</sup> Qtr. Finance & Admin Mtg.

SEPTEMBER						
S	M	T	W	Th	F	S
				1	2	3
4	5	6	7	8	9	10
11	12	13	14	15	16	17
18	19	20	21	22	23	24
25	26	27	28	29	30	

Sept. 14 Board Meeting

APRIL						
S	M	T	W	Th	F	S
					1	2
3	4	5	6	7	8	9
10	11	12	13	14	15	16
17	18	19	20	21	22	23
24	25	26	27	28	29	30

Apr. 4 Operations Committee Mtg.  
Apr. 13 Board Meeting  
Public Meeting/Groundwater Charge  
Apr. 27 Board Meeting  
Public Hearing/Groundwater Charge

OCTOBER						
S	M	T	W	Th	F	S
						1
2	3	4	5	6	7	8
9	10	11	12	13	14	15
16	17	18	19	20	21	22
23	24	25	26	27	28	29
30	31					

Oct. 4 Operations Committee Mtg.  
Oct. 12 Board Meeting

MAY						
S	M	T	W	Th	F	S
1	2	3	4	5	6	7
8	9	10	11	12	13	14
15	16	17	18	19	20	21
22	23	24	25	26	27	28
29	30	31				

May 11 Board Meeting @ 9:00 a.m.

NOVEMBER						
S	M	T	W	Th	F	S
		1	2	3	4	5
6	7	8	9	10	11	12
13	14	15	16	17	18	19
20	21	22	23	24	25	26
27	28	29	30			

Nov. 9 Board Meeting  
Nov. 16 1<sup>st</sup> Qtr. Finance & Admin Mtg.

JUNE						
S	M	T	W	Th	F	S
			1	2	3	4
5	6	7	8	9	10	11
12	13	14	15	16	17	18
19	20	21	22	23	24	25
26	27	28	29	30		

Jun. 8 Board Meeting

DECEMBER						
S	M	T	W	Th	F	S
				1	2	3
4	5	6	7	8	9	10
11	12	13	14	15	16	17
18	19	20	21	22	23	24
25	26	27	28	29	30	31

Dec. 14 Board Meeting (@ 9:30 a.m.)  
Annual Luncheon

# Wash Plan Trails Status Report

April 2022



**San Bernardino Valley  
Water Conservation District**

Helping Nature Store Our Water

---

## Project Management Approach / Work Plan

- a. Develop/obtain support from Cities on trails MOU
- b. Complete trail permitting, including 1) Wash Plan HCP Certificate of Inclusion and 2) State/waters permits
- c. Record public access easements, if necessary
- d. Install signs/fencing
- e. Open trail(s) that do not require ancillary facilities such as trailheads or parking lots
- f. Obtain grant funding for ancillary trail facilities such as trailheads and parking lots
- g. Bid construction of/build ancillary trail facilities



## Current Status

District staff continue to work with the City of Redlands towards adoption of the Trail MOU, with a tentative Council hearing in Spring 2022. Redlands has requested a five-party agreement between the cities, mining companies, and the District to clarify implementation items such as payment. District Counsel has drafted an agreement for review by the parties.

Trails were included in the Wash Plan state and waters permitting applications which were submitted to the regulatory agencies in 2021. Trail opening will be dependent upon receipt of these permits, as well as final approval from USFWS, which included conditional approval in the Wash Plan HCP.

# General Manager's Report

From March 5, 2022 to April 12, 2022  
Daniel B. Cozad and Betsy Miller



**San Bernardino Valley  
Water Conservation District**

Helping Nature Store Our Water

---

The District currently remains at Phase 2 COVID 19 response level. CalOSHA Standards for COVID require masks by unvaccinated or undocumented staff in the office's common areas. CDC and State Health guidelines recommend or require masks by all staff in common areas. California cases have continued to fall with a slight increase in San Bernardino County cases, which remain well below peak January levels. Staff will notice all Board meetings as in-person/hybrid as allowed by the Brown Act or health guidance allows.

The following report covers the weeks between meetings and the efforts and activities during the reporting period.

- 1. Water Conservation – Plan Goal 1** – Santa Ana River, Mill, and Plunge Creeks were dry for several months. December storms added flow and some fire-related sediment; however, January and February were primarily dry with limited flows in March. Mill Creek's total recharge for the Water Year is over 1100 AF. The Santa Ana River recharge is projected to be nearly 6000 AF for the Water Year beginning in October. Plunge Creek recharge is still showing good recharge at about 850 AF. The total recharge is just over 8,225 AF.
- 2. Facility Maintenance and Cleanout – Plan Goal 1** – Normal winter water operations are underway, and all facilities are in operation.
- 3. Aggregate Management – Plan Goal 1** – Upland Rock continues screening and selling sand and rock from District basin cleaning efforts and supporting land management efforts and costs.
- 4. Personnel/Administration/Staff** – Staff continues to monitor and implement the District Extreme Flu/COVID19 plan. Staff is using the modified work program to increase effectiveness and maintain office occupation limits. The vacant Assistant Engineer position was posted in early February; we received limited applicants and will post the position again prior to conducting interviews. An RFP for technology modernization and support was posted on April 4 in order to allow us to have a cost range ahead of the budget workshop.
- 5. Finance/Budget/Audit** – Staff is implementing the annual budget and reviewed it compared to Third Quarter operating results. The third quarter unaudited financial reports and a preliminary FY23 budget were presented to the Finance & Administration Committee on March 23. The Ad Hoc Audit committee discussed the four proposals received in response to our RFP on March 30. The recommendations of both committees were forwarded to the Board. Staff is preparing the FY23 budget for the up-coming Board workshop, based on the previously approved groundwater charge and related revenue and expenses.

6. **Mill Creek Diversion Engineering** – *Plan Goals 1/4* – Erwin reports on the engineering and construction projects at meetings when updates are not included in agenda items. Staff continues to provide the additional requested information for environmental and engineering questions in the hopes of having permits in time to construct in 2022.
7. **Plunge Creek Conservation Project** – *Plan Goals 1/4* – Both operations and habitat management and monitoring efforts are ongoing. December storms made significant changes in the project and expanded the footprint of the waters area by more than eight acres. Recharge for this water year has been good, about 825 AF.
8. **Enhanced Recharge Project** – *Plan Goal 1* – The Enhanced Recharge Phase 1A is completed. Engineering design is nearing completion for the new basins scheduled for construction in 2022. The District has reviewed the Wash Plan Certificate of Inclusion for this project and submitted it to USFWS. The State and Waters permits needed to proceed are being processed by SBVMWD.
9. **Active Recharge Transfer Project Partnership** – *Plan Goals 1, 2, and 4* – The Board has approved all three feasibility studies and a kick-off meeting has been held with each firm. A field trip to the ARTP sites, with Board members and staff from Valley and the District, was held on March 10.
10. **Edison Divestiture to Water Users** – *Plan Goals 1/4* – The consortium met in late March and early April and expects to continue weekly or biweekly meetings as appropriate to review SCE information and feedback.
11. **Groundwater Council** – *Plan Goal 1* – The Groundwater Council met on February 14, 2022, and approved the draft budget, water credits, and other issues. The Council is meeting to discuss renewal of the agreement in late April.
12. **Shop Facilities for Field Staff** – *Plan Goals - 1* – Erwin provides a separate report for the Board.
13. **Wildland Trails** – *Plan Goal 3* – Developing and opening Wildland Trails on District property is a Board priority and now has a separate report listed on the agenda. The Highland City Council approved the Agreement on January 11, 2022, and the Board approved it on January 12, 2022. Staff has been working on several comments from Redlands to get the agreement on the Council agenda for consideration in Spring 2022.
14. **Wash Plan** – *Plan Goal 4* – The Wash Plan has a separate report listed on the agenda. Staff continues to work with AECOM on permitting, and staff has met with the Army Corps of Engineers, Regional Water Quality Control Board, and California Department of Fish and Wildlife to discuss draft permits and move toward agreement on final permit conditions. Wash Plan Year 2 implementation task are underway, and will be covered in the Wash Plan verbal update.
15. **Santa Ana River Wash Plan Land Exchange Act Implementation** – *Plan Goal 4* – S.-47 was passed and signed by the President, becoming PL 119-6. Staff, District Counsel, answered questions for the Appraiser and Reviewing Appraiser assisting BLM. Staff and

the BLM are working on the description of work needed in the Right of Way to support the District's activities under the land transferred to BLM. Staff and Dudek are coordinating on an expedited NEPA review in support of ROW issuance by BLM. Staff is working with BLM to set up a reimbursement account for review of the EA.

- 16. Conservation Trust – Plan Goal 4** – The Conservation Trust Board of Directors is schedule to meet on April 20. The District and Trust have been reimbursed for services and funding for conservation easements and contribution, with additional progress expected following recent coordination meetings with CDFW.
- 17. Property/Redlands Plaza** – Staff continues to manage Redlands Plaza tenants and maintenance issues. All units are now fully leased, with the church is working with the City on permitting the changes needed for the CUP. District Counsel is working with Red Dragonfly Spa to vacate the suite as their lease has expired.
- 18. Mining** – Mining efforts by CEMEX contractors continue at the Plant Site quarry. Mining above the guaranteed minimum continues resulting in additional revenue to the Land Enterprise.
- 19. Public Outreach and Legislative – Plan Goal 5** IERCD has conducted several outreach events on the District's behalf. District staff Milan Mitrovich provided a guest lecture at his son's 5<sup>th</sup> grade classroom on groundwater recharge efforts on March 25. Daniel Cozad was selected as the recipient of ACWA's Excellence in Water Leadership Award, and the District's Plunge Creek Conservation Project was selected as a finalist for ACWA's Excellence in Innovation Award. The Watershed Connect program, which included the City of San Bernardino Water Department, Yucaipa Valley Water District, Valley District, and the Conservation District, was also selected as a finalized for ACWA's Excellence in Innovation Award. Staff and consultants continue to work on the 90th Anniversary celebration of the District's founding on May 12, 2022. Daniel Cozad and Betsy Miller attended the first Upper Santa Ana River Mayor's Breakfast hosted by Valley District. Daniel Cozad signed a support letter for Valley District's Congressionally Directed Spending/Community Project Funding Request for the Enhanced Recharge Project (see attached).
- 20. Current Board Action Implementation** – Many priority efforts have separate sections of the General Manager's Report or independent Board requested reports. Significant staff resources are allocated to the ARTP and Wash Plan projects. Staff and District Counsel are continuing to work closely on EHL/CBD v. USACOE settlement-related studies. Trails MOU with Redlands continues to be a priority.
- 21. Future Board Activities** – Expected short-term items for consideration or note:
  - Exchange Plan Amendment – the Task Force reviewed in provided legal and other comments, and after the resolution, Board consideration is planned for early 2022.
  - BLM Land MOU/ROW working with BLM Regional Manager to complete in mid-2022
  - Alliance JPA for River HCP when completed

## 22. District Successes

- Kick-off meetings have been held for all three of the awarded ARTP contracts. We are excited to recognize this significant milestone for the ARTP program.
- Erwin Fogerson retired from full-time employment on March 31. His colleagues gathered that evening to celebrate with Erwin and wish him many happy Monday and Friday golf games.
- Katelyn Scholte was promoted to Principal Engineer on April 1 following Erwin's retirement. We are proud of Katelyn's professional growth as a District employee and look forward to her continued contributions in her new role.



Erwin opening a retirement gift from his colleagues.

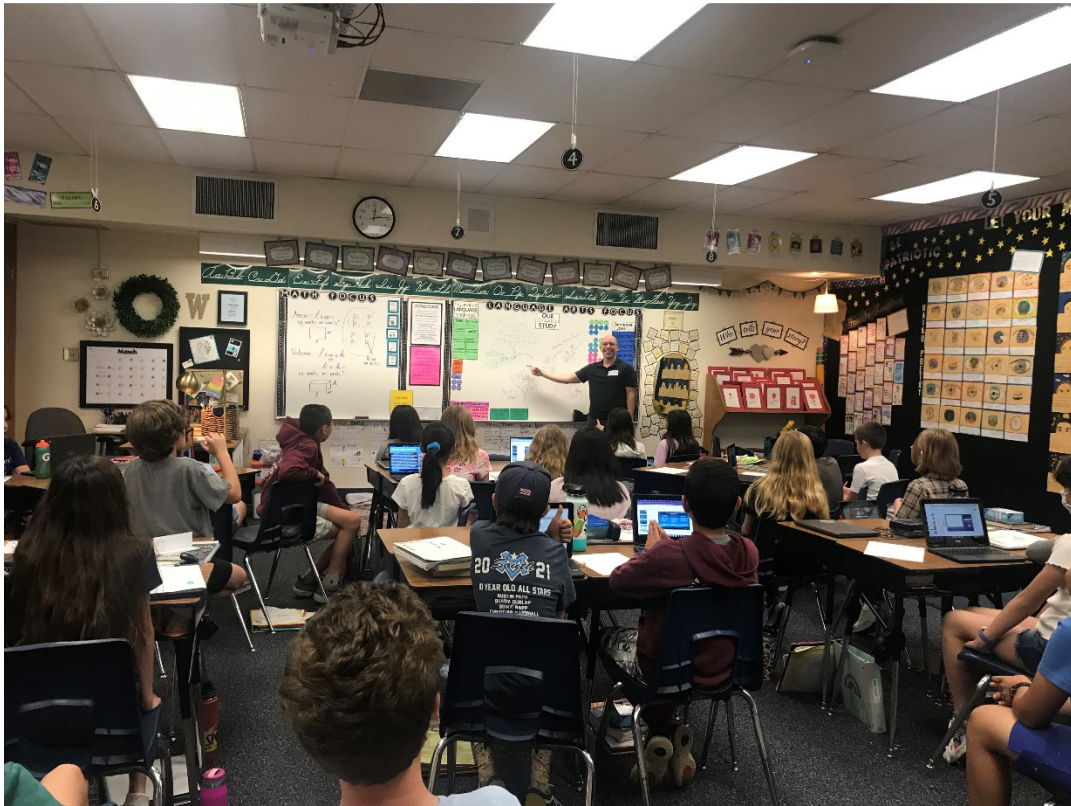

Milan presenting a science lecture at his son's 5<sup>th</sup> grade with a focus on groundwater recharge and endangered species conservation.



**San Bernardino Valley  
Water Conservation District**  
Helping Nature Store Our Water

March 29, 2022

The Honorable Dianne Feinstein  
United States Senate  
331 Hart Senate Office Building  
Washington, D.C. 20510

The Honorable Alex Padilla  
United States Senate  
112 Hart Senate Office Building  
Washington, DC 20510

The Honorable Pete Aguilar  
United States House of Representatives  
109 Cannon House Office Building  
Washington, DC 20515

RE: Support for the San Bernardino Valley Municipal Water District's Congressionally Directed Spending / Community Project Funding Request

Dear Senators Feinstein and Padilla and Representative Aguilar,

On behalf of the San Bernardino Valley Water Conservation District, we continue to support the San Bernardino Valley Municipal Water District's Santa Ana River Enhanced Recharge Phase 1B Project (Project). The Project is a partnership with our District and consists of improving existing facilities and constructing new facilities to increase the amount of stormwater from the Santa Ana River that can be captured and recharged. We strongly support their Congressionally Directed Spending / Community Project Funding Request.

Given the drought conditions in the Santa Ana River Watershed and throughout California, additional capture of stormwater is critical to sustainable groundwater supplies that are important to our region's community health and economic health as it adapts to climate change. When complete, the Project will provide 15,412 acre-feet per year, average recharge that benefits the 400,000 people in our basin, who are all reliant on groundwater.

This Project is just one of the regional partnership projects supported by the San Bernardino Valley Municipal Water District and the Water Conservation District to continue both agencies' commitments to better manage our water and natural resources to benefit the community with a reliable and sustainable water supply and the environment. We urge the inclusion of this Project in your list of priorities.

If you have any questions or concerns, don't hesitate to contact us at: (909) 793-2503.

Sincerely,

Daniel B. Cozad  
General Manager

1630 W. Redlands Blvd, Suite A  
Redlands, CA 92373  
Phone: 909.793.2503  
Fax: 909.793.0188  
www.sbvwc.org Email: info@sbvwc.org

**BOARD OF DIRECTORS**

Division 1:  
Richard Corneille  
Division 2:  
David E. Raley

Division 3:  
Robert Stewart

Division 4:  
John Longville

Division 5:  
Melody McDonald

**GENERAL MANAGER**

Daniel B. Cozad

# San Bernardino Valley Water Conservation District

## Monthly Recharge Report

From: 3/1/2022  
To: 3/31/2022



	March				
	Avg Daily Recharge	Monthly Recharge	Recharge WYTD	10yr Avg Recharge*	BTAC Max**
Santa Ana River	6.1	189	6,148	10,018	176,625
Mill Creek	4.1	128	987	3,354	105,975
Plunge Creek	1.2	36.2	851	107	#N/A
State Water Project	0.0	-	9	6,681	#N/A
In River Channel Recharge***	0.0	-	384	#N/A	#N/A
<b>Total</b>	<b>11</b>	<b>353</b>	<b>8,378</b>	<b>20,160</b>	<b>282,600</b>

Values in Acre Feet

\* Plunge Creek only has 1 year of available data

\*\*BTAC Revised Max in December 2021

\*\*\*Monitoring began in Mid-April 2011

\*\*\*\* All Values Based on Water Year Oct-Sep 2022

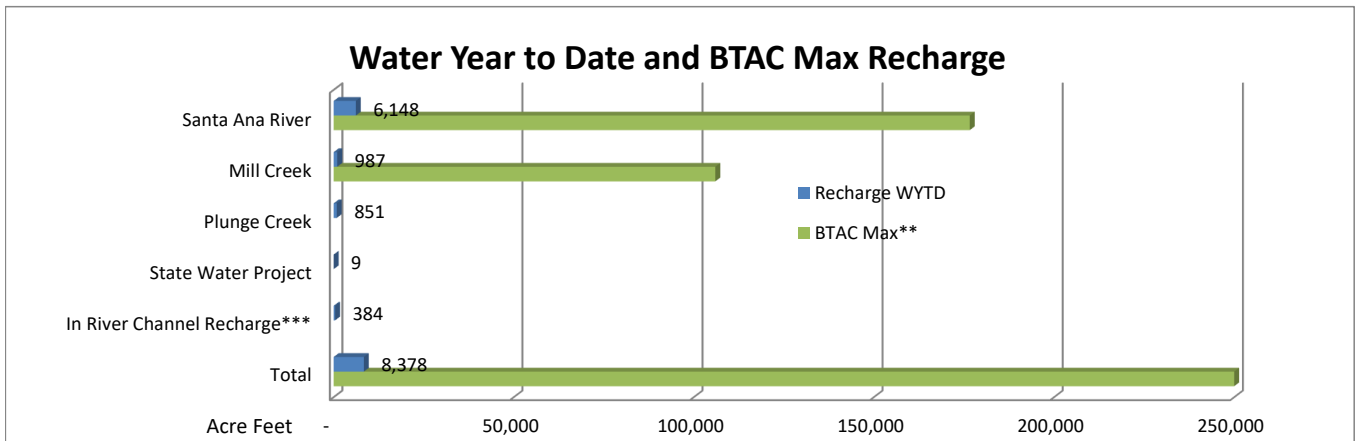
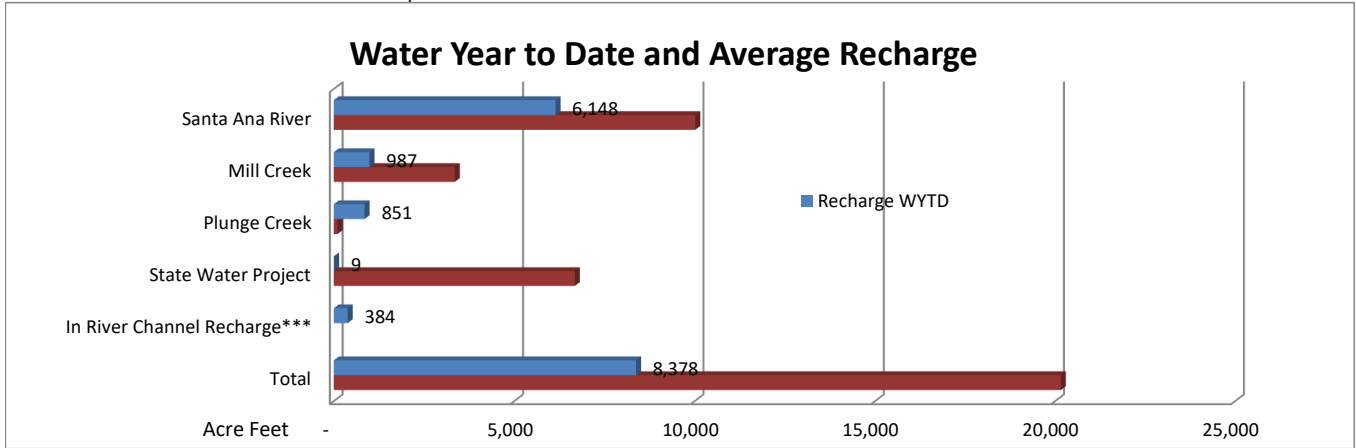

**TRAVEL AND EXPENSES COST ESTIMATE**

<b>Name of Event:</b>	ACWA Spring Conference
<b>Event Dates:</b>	05/02/2022-05/06/2022
<b>Conference Location:</b>	Sacramento, CA
<b>Requested by:</b>	John Longville

<b>GL</b>	<b>GL Name</b>	<b>Cost</b>	<b>Notes</b>
	6401 Directors Fees (\$246)	\$ 1,230.00	5 days
	6410 Mileage (.585)	\$ -	Roundtrip
	6415 Air Fare	\$ 437.97	
	6420 Other Travel	\$ 50.00	(Parking/Taxi/Rental Car)
	6425 Meals	\$ 50.00	
	6430 Lodging	\$ 1,017.96	
	6435 Conference Registration (Full)	\$ 775.00	
	<b>Estimated Total</b>	<b>\$ 3,560.93</b>	